

---

*Application of OIF UNI 2.0 to Emerging  
Transport Network Technologies*

**Vishnu Shukla**

**Verizon, USA**

Vishnu.Shukla@verizon.com

**ECOC 2009, Vienna**

**September 20, 2009**

# *Outline*

---

- ◆ **Transport network reference domains**
- ◆ **ASON Reference architecture**
- ◆ **CP Physical Architecture**
- ◆ **OIF UNI**
- ◆ **Multilayer CP model**
- ◆ **Global testing topology and test cases**
- ◆ **Summary**

# Typical Transport Network Reference Domains

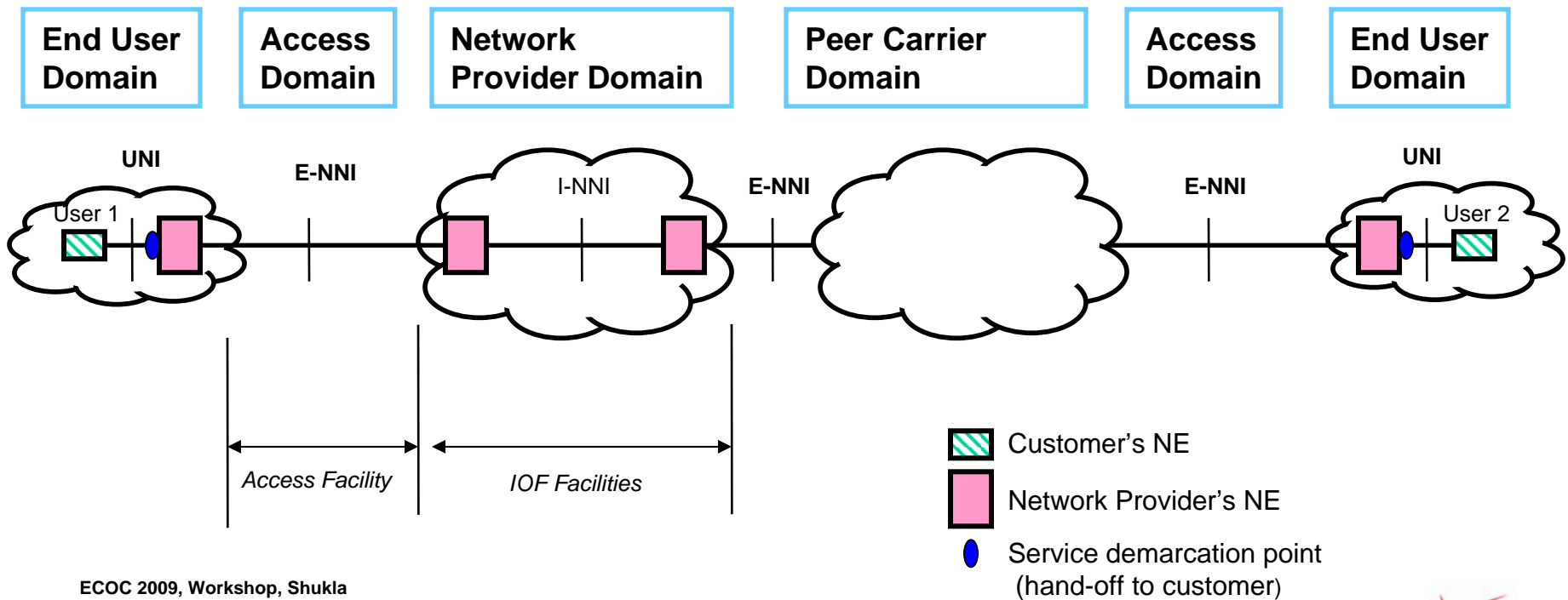

# ITU-T ASON Architecture Interfaces

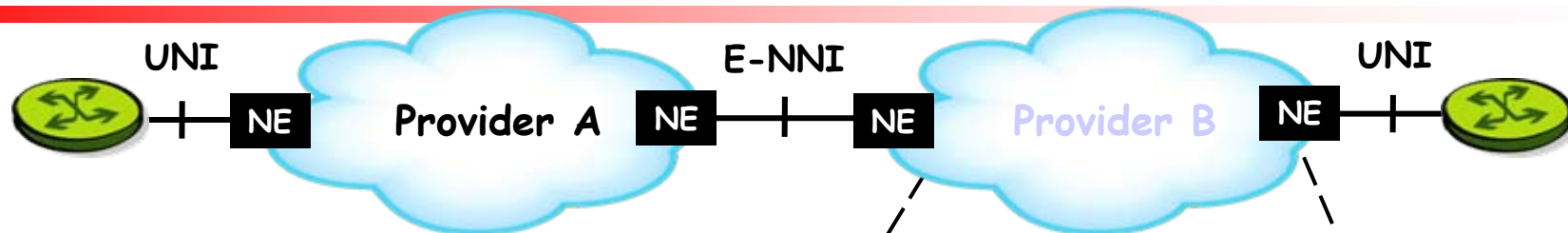

UNI separates the concerns of the client and network provider: Topology, resources and addressing of the optical network are not revealed to the clients

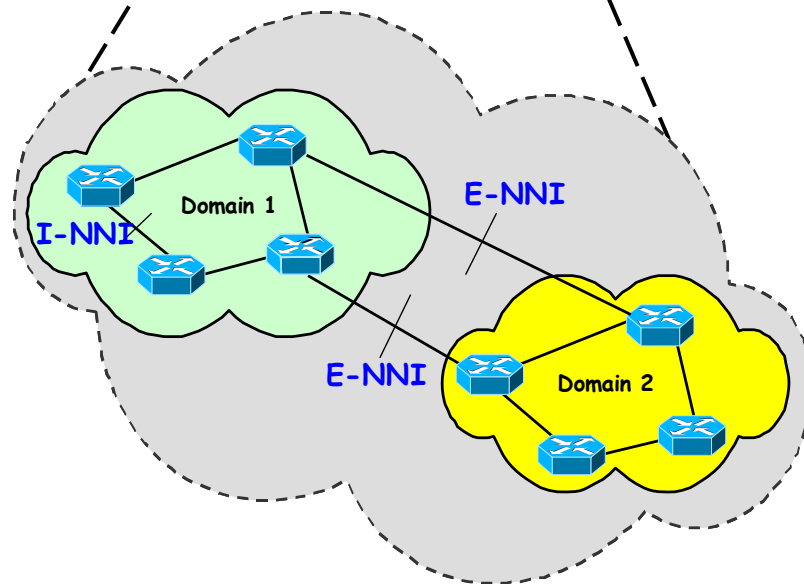

## UNI enables:

- Client driven end-to-end service activation
- Multi-vendor inter-working
- Multi-client
  - IP, Ethernet, TDM, etc.
- Multi-service
  - SONET/SDH, Ethernet, etc.
- VPNs, BoD

# ITU-T ASON Architecture Interfaces

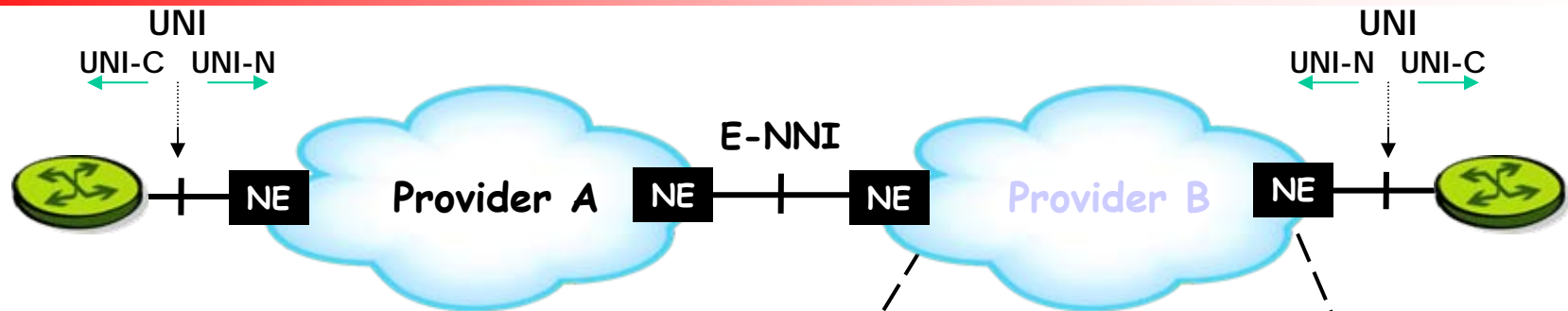

## E-NNI enables:

- End-to-end service activation
- Multi-vendor inter-working
- Multi-carrier inter-working
- Independence of survivability schemes for each domain

## I-NNI supports:

- Intra-domain connection establishment
- Explicit connection operations on individual switches

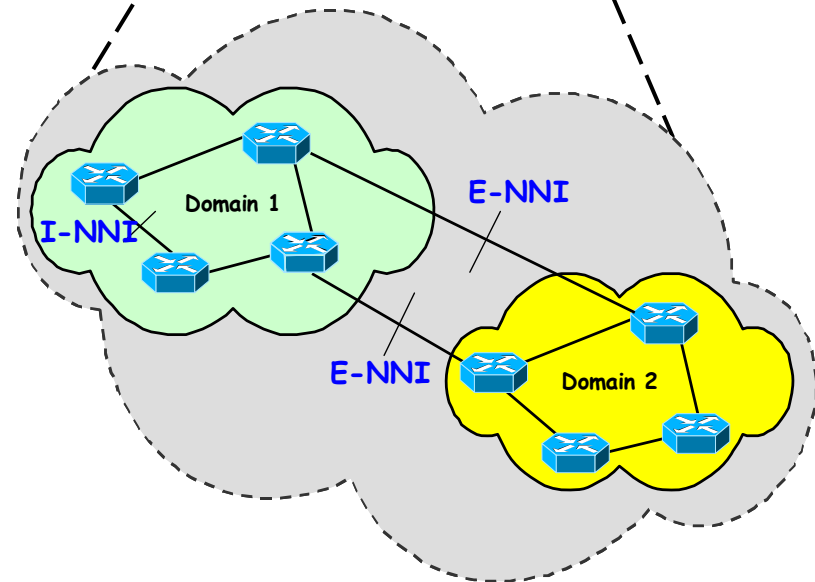

## ◆ Pre-requisites

- Network element resources, such as circuit packs pre-provisioned & made assignable
- Physical facilities pre-wired & available for use

## ◆ Network Topologies – Example (1)

- Full control plane network

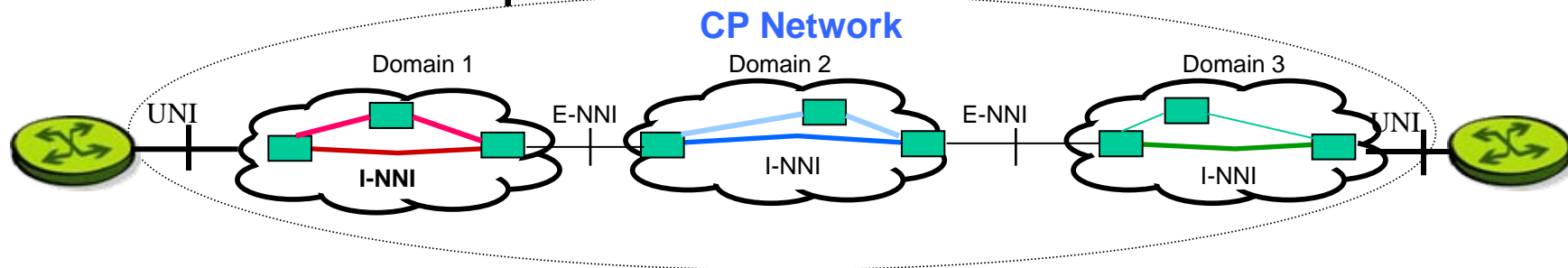

(a) Full CP Network

## ◆ Network Topologies – Example (2)

- Hybrid – mixed control plane & traditional networks

Non-CP Network

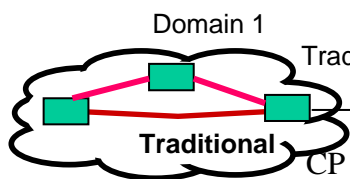

Traditional  
CP Proxy

CP Network

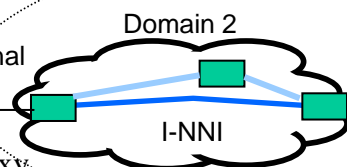

E-NNI

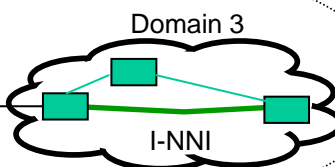

(b) Hybrid Network – Traditional Domain & CP-Domain

Non-CP Network

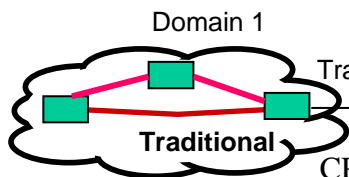

Traditional  
CP Proxy

CP Network

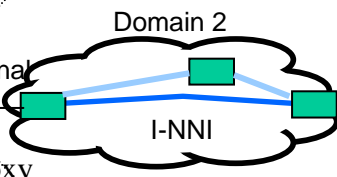

Traditional  
CP Proxy

Non-CP Network

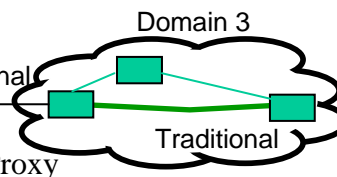

(c) Hybrid Network – Traditional Domain & CP-Domain & Traditional Domain

# OIF User Network Interface Signaling Specifications

- ◆ **Control Plane work driven by Carrier Working Group requirements**
  - Architecture consistent with ITU-T ASON Recs. G.8080, G.7713
  - Signaling specifications in IAs based upon IETF GMPLS RFCs and ITU-T Recs. G.7713.2/3
  - Specifies detailed usage of selected options in protocols
- ◆ **OIF UNI 1.0 Signaling Specification published Oct. '01**
  - Defines the signaling protocols and mechanisms implemented by client and transport network equipment from different vendors to invoke services
  - Feature focus on SDH/SONET VC-3/STS-1 and higher
- ◆ **OIF UNI1.0R2: UNI 1.0 Signaling Specification, Release 2 published Feb. '04**
  - Updates UNI 1.0, but does not change UNI 1.0 functionality
    - Reflects subsequent developments in other standards bodies
    - Builds upon lessons learned from the OIF's multi-vendor interoperability event conducted at OFC 2003

# *OIF User Network Interface Signaling Specifications (cont)*

---

## ◆ **OIF UNI 2.0**

- Incorporates architectural enhancements per ITU-T ASON Rec. G.8080 and G.7713 evolution

## ◆ **Features**

- Ethernet Service
- G.709
- Enhanced security
- Call/connection separation
- Sub-STS1 features
- Non-disruptive call modification
- Multi-homing
- 1:N protection

# Putting the Pieces Together

## *OIF Implementation Agreements and Interoperability Demos*

### OIF Implementation Agreements

ASON/GMPLS Interworking

UNI 1.0 signaling

UNI 1.0r2 signaling  
E-NNI 1.0 signaling

E-NNI 1.0 routing

UNI 2.0 signaling

E-NNI 2.0 signaling

2001

2002

2003

2004

2005

2006

2007

2008

2009

Lab Location	UNH	UNH	Global - 7 carriers	Global - 7 carriers	Global - 7 carriers	Global - carrier labs
Trade Show	SUPERCOMM	OFC	SUPERCOMM	SUPERCOMM	ECOC	Worldwide Interop
New Capabilities Tested	Draft UNI 1.0	Draft E-NNI signaling & routing	CP-enabled SONET/SDH data plane Ethernet over SONET/SDH data plane-only test (GFP/VCAT/LCAS)	Draft extensions for CP-enabled EPL Data plane-only test of EVPL and ELAN	EPL services via pre-IA UNI 2.0 and E-NNI 2.0 over SONET/SDH transport layers CP failure recovery BW modification CP neighbor discovery	EVPL services via UNI 2.0 and E-NNI 2.0 over diverse transport layers • Packet (MPLS-TP and PBB-TE) • SONET/SDH • OTN CP-based restoration

### OIF Networking Interoperability Demonstrations

# OIF Multi-layer Control Plane Model

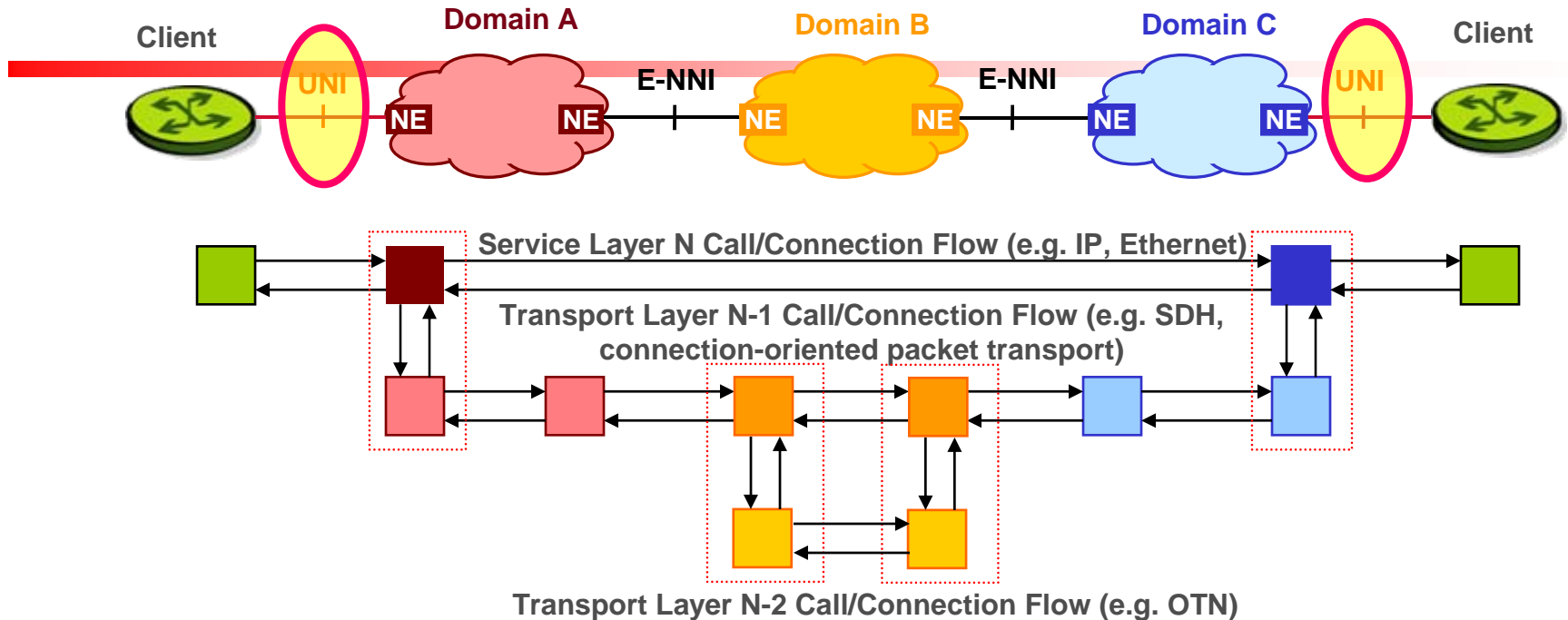

- ♦ Edge nodes typically provide layer adaptation and multi-layer control plane
- ♦ OIF UNI 2.0 Ethernet is applicable to all NG Layer1 and Layer 2 transport network technologies (network technology layer is independent of UNI layer)
  - ♦ EVPL over packet transport networks
  - ♦ EVPL over SONET/SDH and OTN
- ♦ Core nodes typically operate in a single server layer
- ♦ Supports non-disruptive modification (of BW or VLAN IDs) while in-service
- ♦ Versatile – supports only specific layers needed (e.g Eth-VCAT-SDH, packet over WDM) yet supports multiple layer adaptations
- ♦ To keep layers separate UNI Transport Network Administered Address (TNAs) are separate at each layer

# On-Demand Ethernet Services across Global Networks

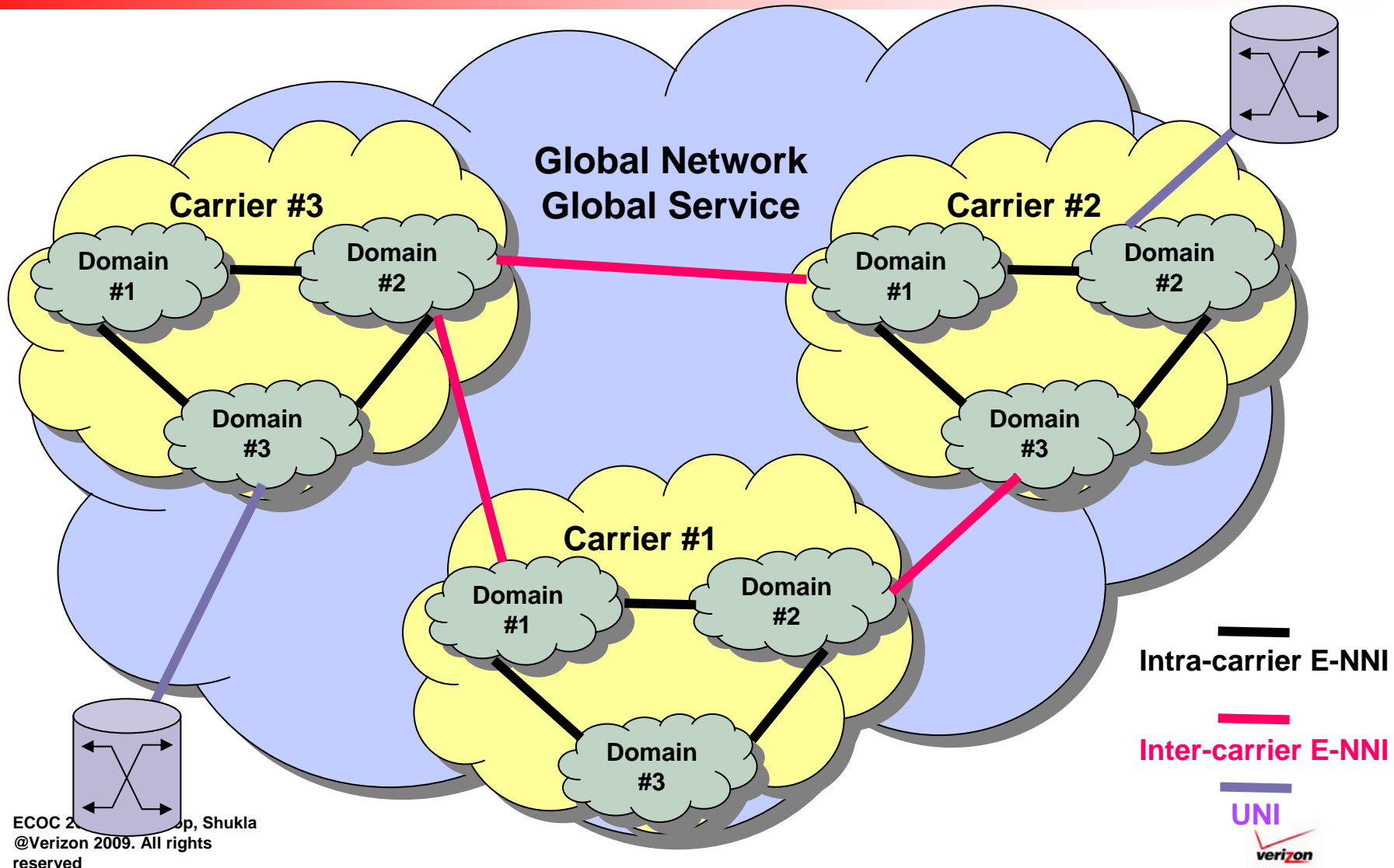

# *OIF 2009 Worldwide Interoperability Demonstration*

- ◆ **End-to-end provisioning of dynamic Ethernet Virtual Private Line (EVPL) services**
  - Over multiple control plane-enabled intelligent optical core networks
  - Using OIF UNI 2.0 and OIF E-NNI 2.0 signaling Implementation Agreements
- ◆ **Supported by (7) major Carriers (China Telecom, Deutsche Telekom, France Telecom, KDDI, NTT, Telecom Italia and Verizon) and (10) leading equipment vendors (Alcatel-Lucent, Ciena, Ericsson, Huawei, Marben, NEC, NSN, Sycamore, Tellabs and ZTE) from Asia, Europe and the USA**
- ◆ **Testing conducted in Carrier labs April – June 2009**



*On-Demand Ethernet Services across Global Networks*

*Worldwide Interoperability  
Practical Test Cases*

---

- ◆ **Heterogeneous multi-vendor and multi-domain networks with ASON/GMPLS-enabled nodes and domains**
- ◆ **Interconnected via an OIF control plane with inter-domain links and supported by a global SCN**
- ◆ **UNI 2.0 for EVPL services over PBB-TE and MPLS-TP transport**
- ◆ **UNI 2.0 and E-NNI 2.0 for EVPL services over SONET/SDH, OTN**

# OIF EVPL SONET/SDH Global Topology

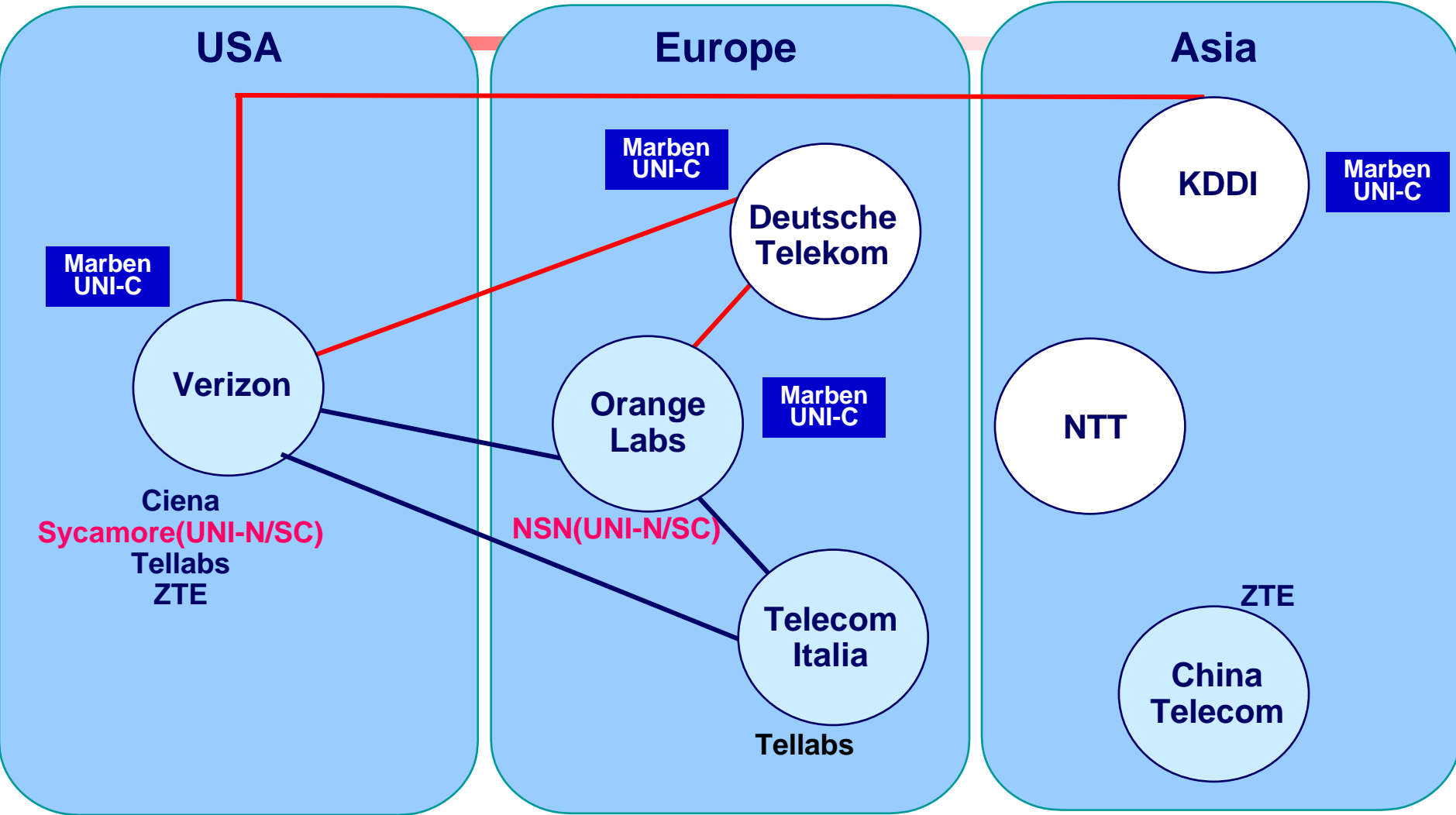

# OIF MPLS-based Packet Transport Global Topology

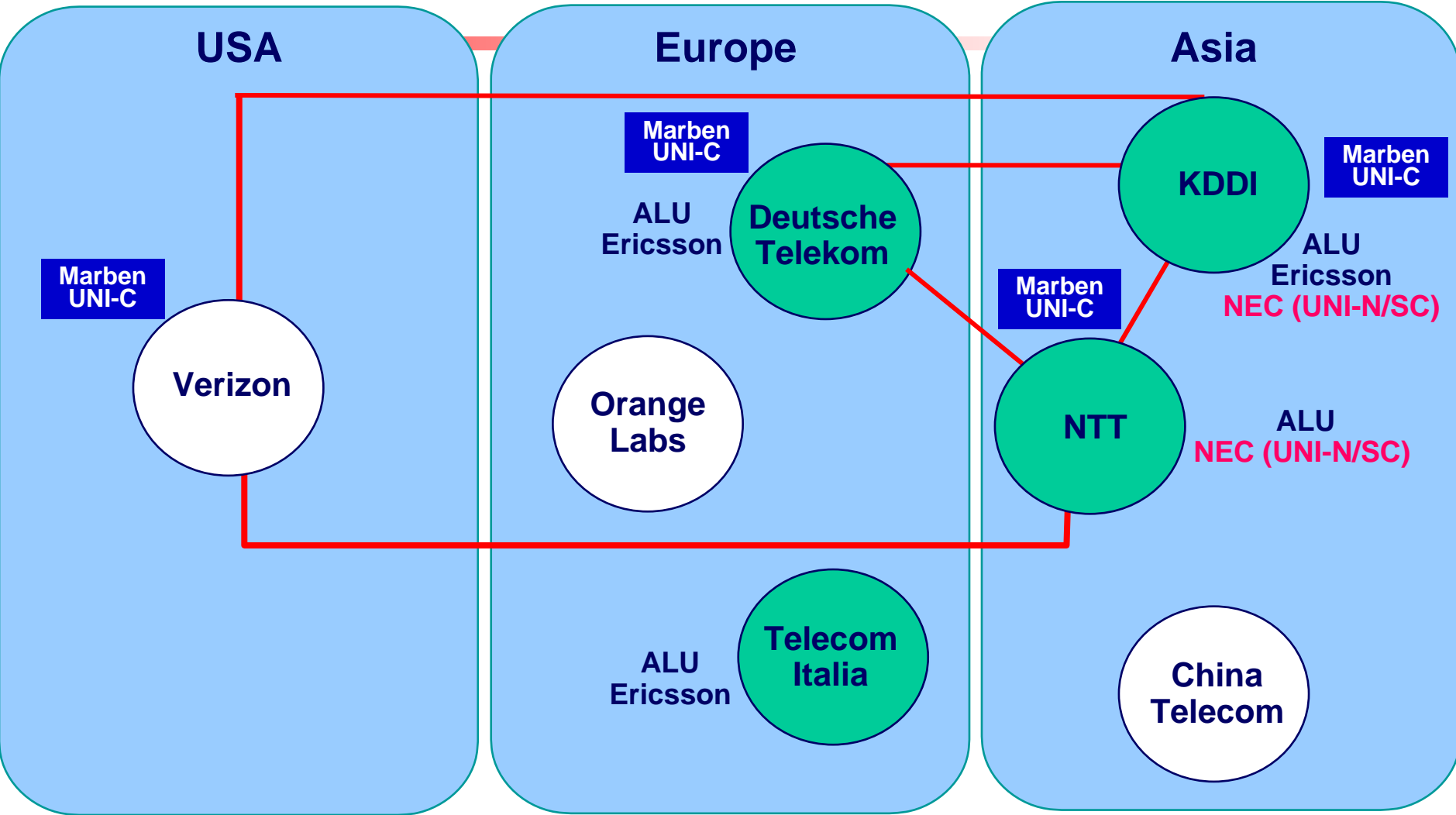

# Verizon Lab Topology

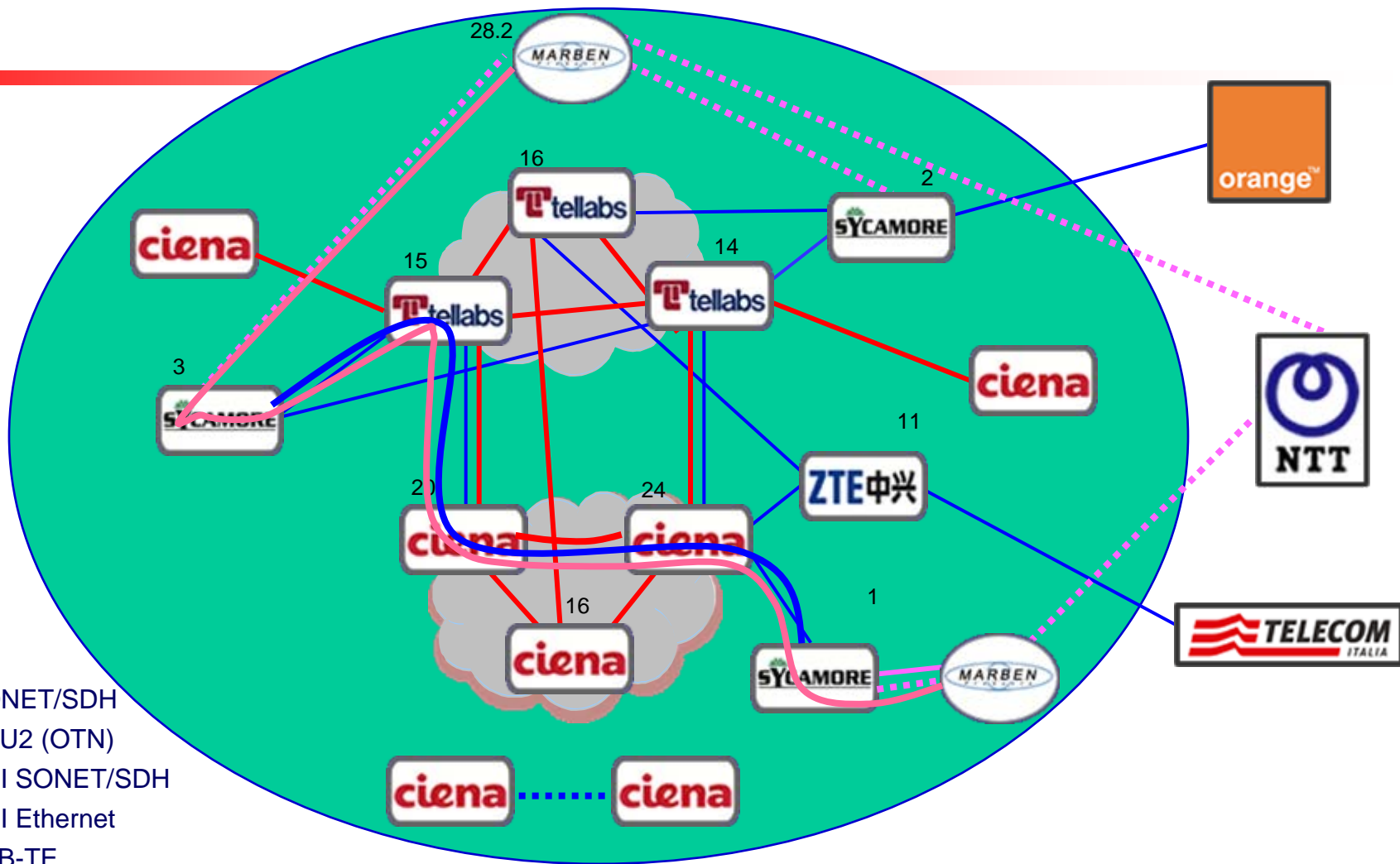

- SONET/SDH
- OTU2 (OTN)
- UNI SONET/SDH
- UNI Ethernet
- PBB-TE
- MPLS-based

# EVPLoMPLS Demonstration Topology

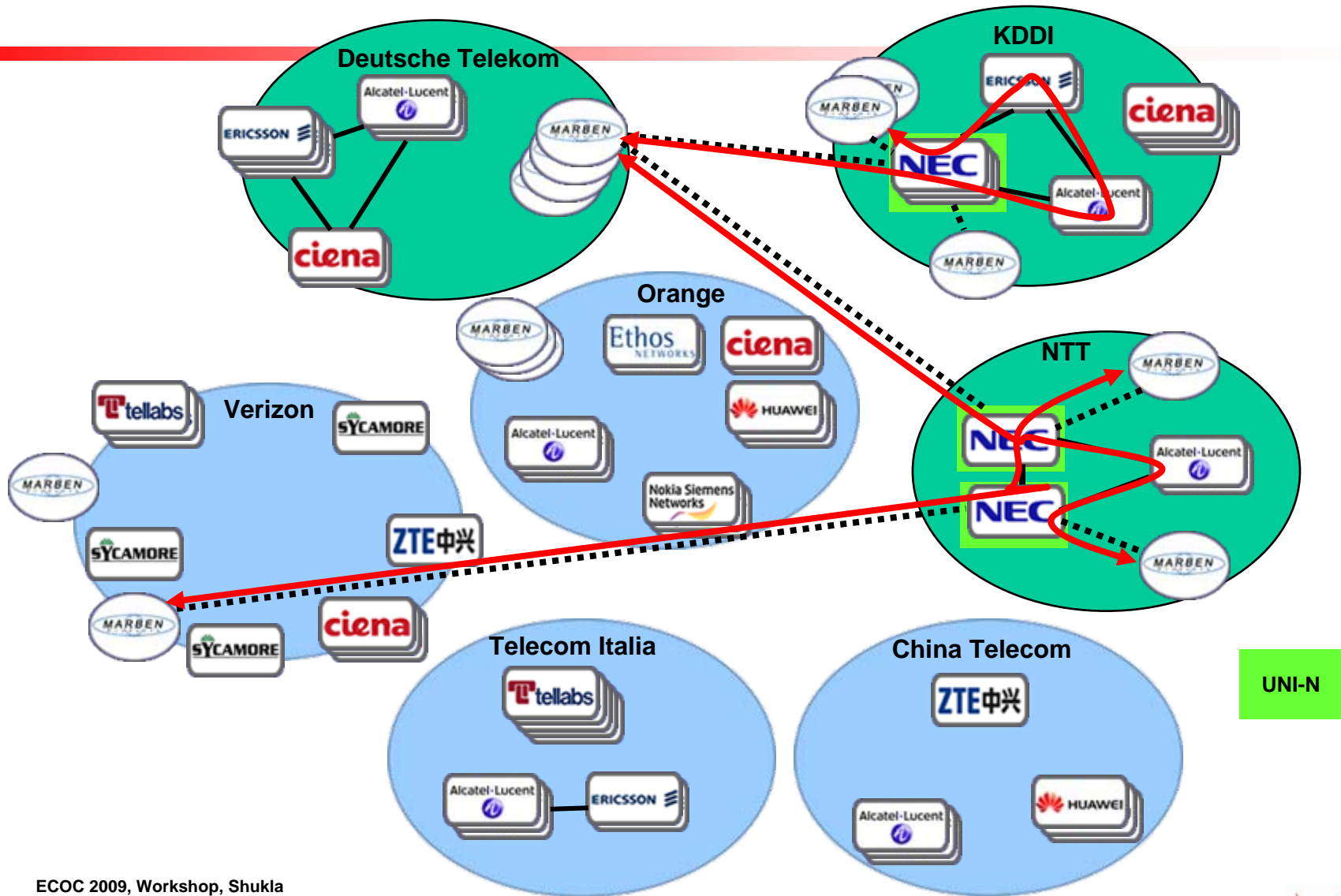

## *EVPLoMPLS Connection Table*

---

- ◆ **EVPLs are established by intra-lab and inter-lab UNI signaling.**
  - MPLS-based LSPs are statically configured.
  - Clients initiate service request using UNI 2.0 signaling
  - UNI-N devices create Ethernet pseudowires over the existing MPLS LSPs

# EVPLoS Demonstration Topology

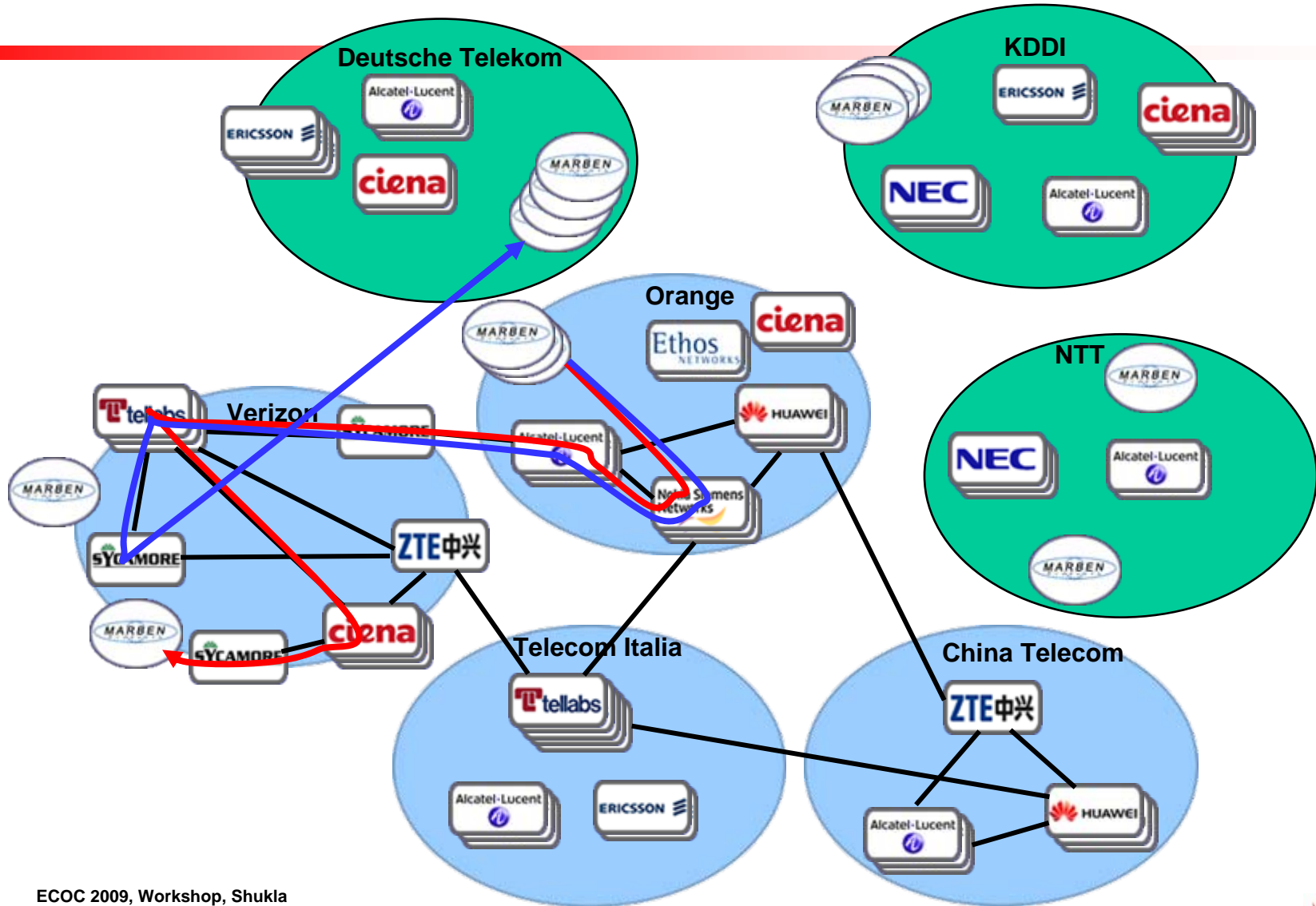

## *Summary and Conclusions*

---

- ◆ **Extensive interop testing enables stable UNI and E-NNI IAs and facilitates network deployment**
- ◆ **Carriers can provision end-to-end dynamic connections for flexible data services over multiple, control plane enabled transport domains and technologies**
- ◆ **Carriers are enabled to select cost effective and innovative network elements, platforms and multi-vendor solutions**
- ◆ **Carriers can reduce operations overhead and simplify provisioning of new services**