

Ethernet Evolution & PBB-TE

Dr. Larry Dennison
CTO Soapstone Networks™

Presented by Mike Lerer
Consultant Office of the CTO
mlexer@soapstonenetworks.com



OIF

OPTICAL
INTERNETWORKING
FORUM

Copyright 2008

Introduction

- ◆ **Avici Systems (AVCI) has formed a new business unit**
 - **Soapstone Networks™ leverages expertise learned from routing and applies it to new area**
- ◆ **Soapstone Networks Provider Network Controller**
 - **Dynamic Control Plane – abstracts transport network**
 - **Vendor Agnostic, Technology Agnostic**
- ◆ **Mike Lerer**
 - **Consultant in the Office of the CTO (Dr. Larry Dennison)**
 - **An OIF/NPF Veteran**
 - **Former Chairman of the OIF PLL**
 - **Former Chairman of the NPF Software Working Group**
 - **Former Chairman of the NPF Hardware Working Group**

NGN Transformation: Value is in Software/Services

“Old world” monolithic stovepipe structure

“New world” layered NGN structure

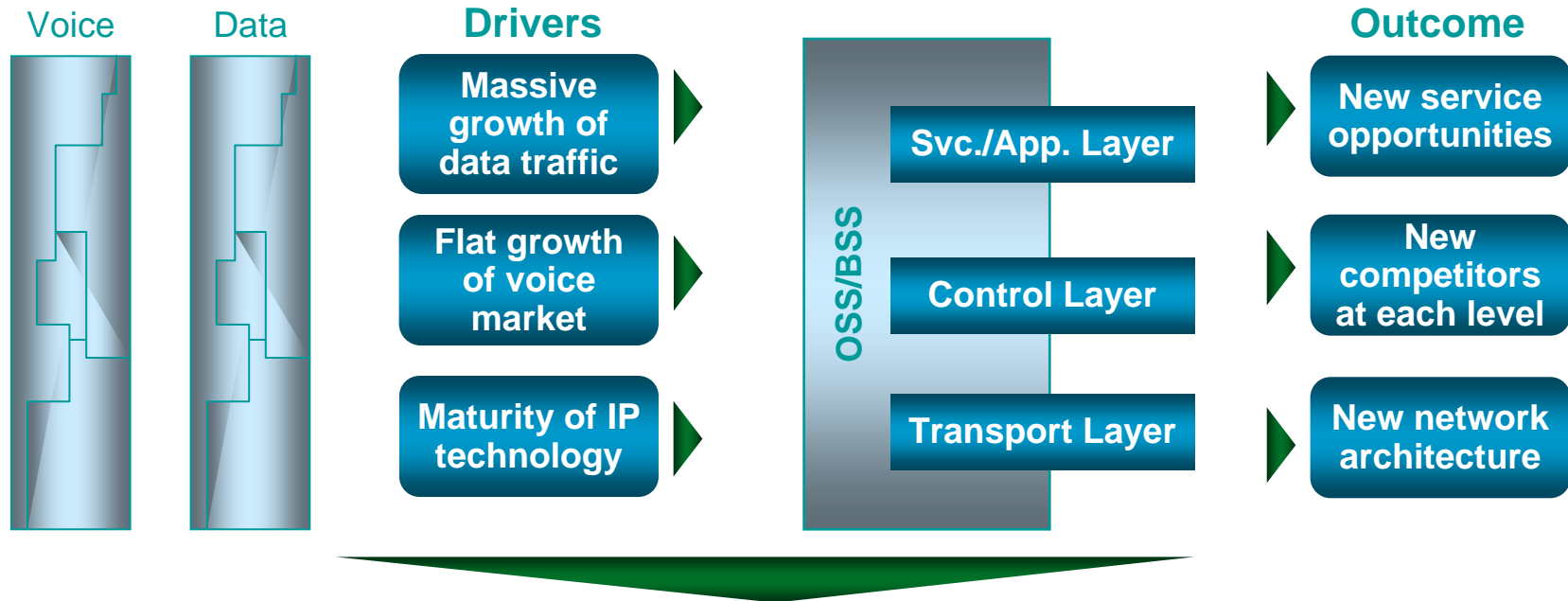

Carriers no longer have one or two applications large enough to justify independent stovepipes

Business Rationale for NGN Transform

**Today:
Multiple Services - Multiple Platforms**

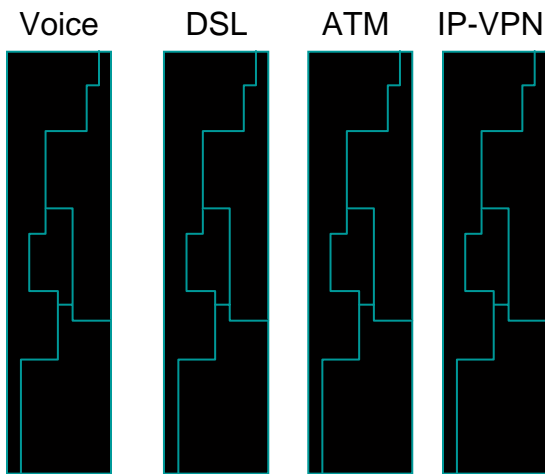

**Tomorrow:
Multiple Services - Few Platform(s)**

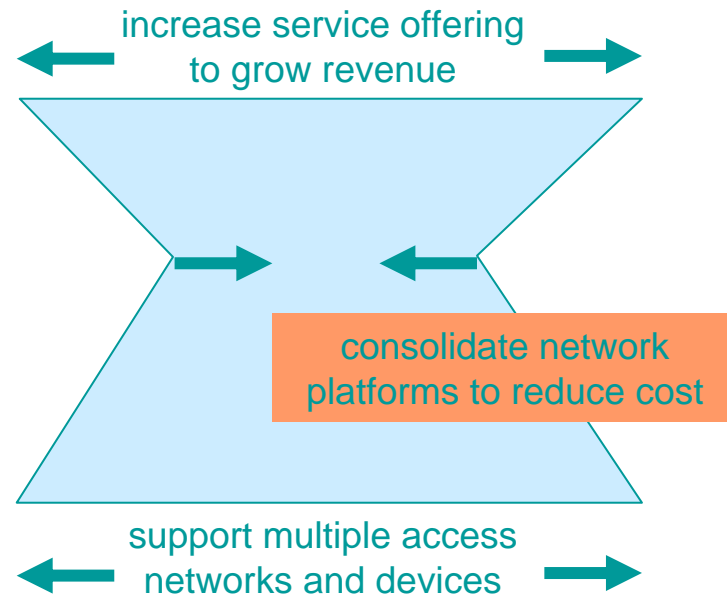

The convergence of services onto a single service-independent infrastructure forces carriers to create separate service and network domains

Mapping Services to Transport

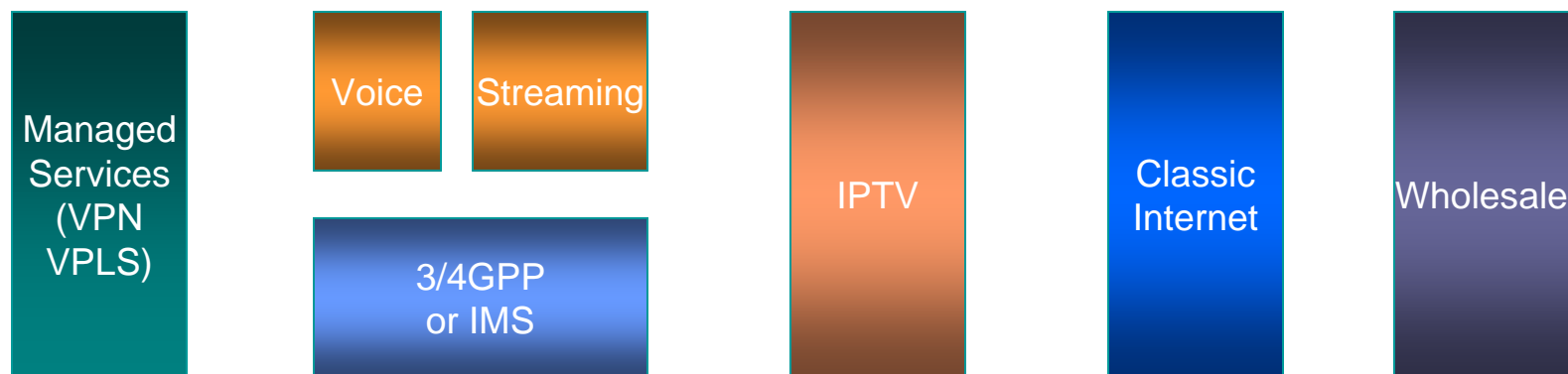

Transport Abstraction



Vendor Boundary vs. Connection Extent

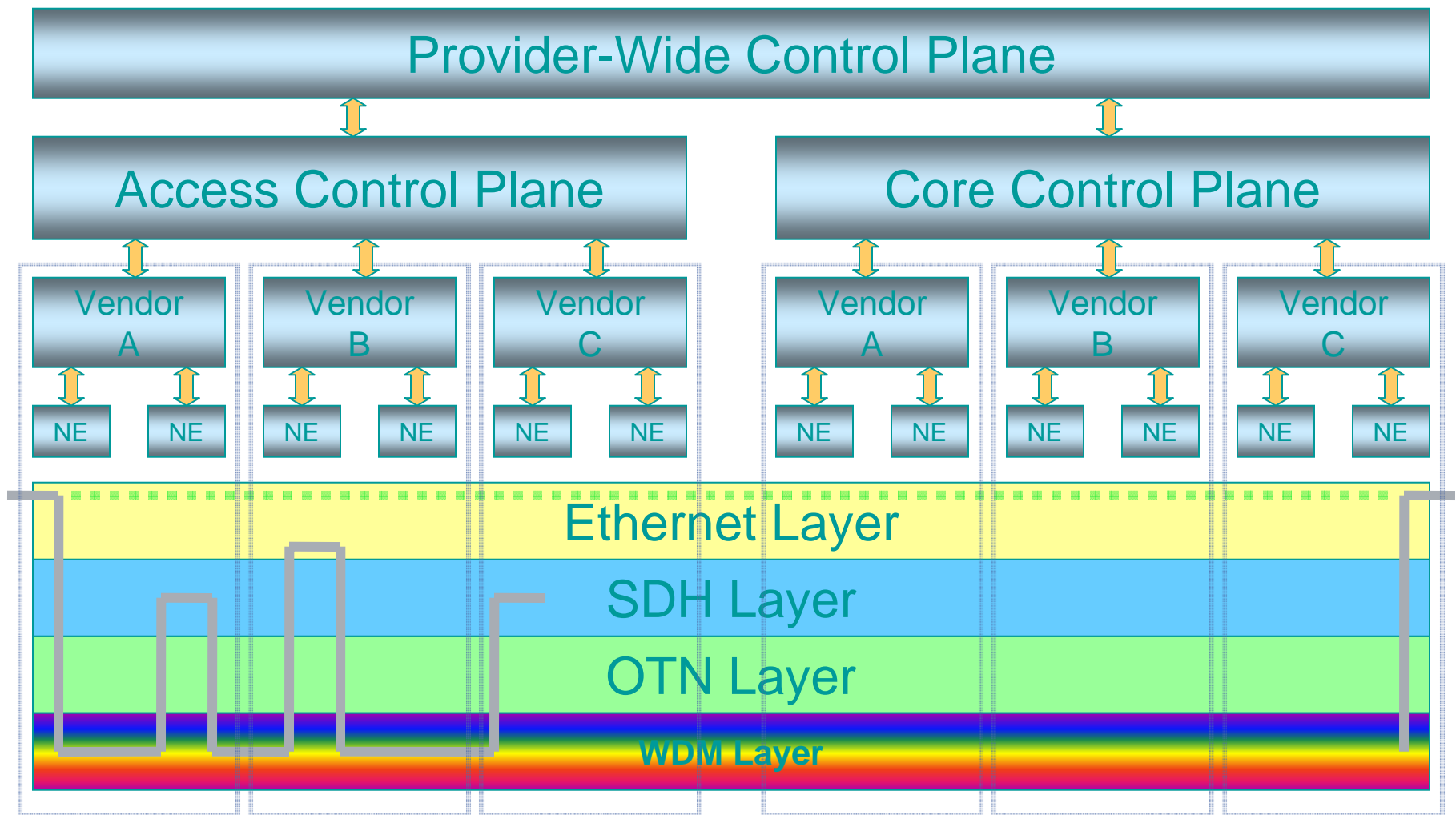

Issue #1

Circuits



Define services based on network technology

- A key attribute, the predictability of circuits, was lost
- A critical value proposition, the quality of the customer's total experience, was undermined. (Issues with Performance Assurance, Fault Detection and Fault Remediation.)

Clouds



Define services based on network technology

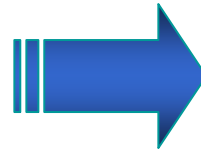

Service Unbundling and Uniform Access

- ◆ Regulatory requirements come and go, but single common attribute always exists: Fair access
 - Public assets used to construct services (cell towers, rights of way, etc..)

Security –increasingly important

- ◆ Privacy to protect both the User and the Network Operator
 - Isolation of User Data
 - Protection of Network Information from Competitors
- ◆ Control
 - External Interfaces (UNI, NNI) must mediate external control and enforce policy.

Evolutionary Forces in Action

- ◆ **The revenue imperative**
 - Find new applications
 - Find new customers for existing services
- ◆ **Services building block**
 - Moved beyond selling connectivity, sell applications
 - Automation
 - Wholesale and retail
 - Regulatory compliance
- ◆ **Enterprise re-use**
 - Data plane elements are common to both enterprise and carrier

Evolving from the Enterprise to the Carrier

Why Carrier Ethernet?

- Ethernet is ubiquitous in enterprises
- Ethernet is high volume, low cost solution
- Extending Ethernet to Service Provider Space
 - Provides simplification of overall network (all Ethernet everywhere)
 - Carrier Ethernet leverages enterprise Ethernet cost and volume advantages

Evolving from the Enterprise to the Carrier

How do you address the need for OAM?

- **IEEE 802.1AB Station and Media Access Control Connectivity Discovery**
- **IEEE 802.1ag Connectivity Fault Management**
- **ITU G.8031 SG15 Ethernet Protection Switching**
- **ITU Y.1731 SG13 OAM functions and mechanisms for Ethernet based networks**

Evolving from the Enterprise to the Carrier

How do you address the need for Scalability?

- IEEE 802.1ah Provider Backbone Bridges
- IEEE 802.1Qay Provider Backbone Bridge Traffic Engineering

Evolving from the Enterprise to the Carrier

How do you leverage the NGN trends to create a different type of Ethernet?

- IEEE 802.1Qay Provider Backbone Bridges – Traffic Engineering PBB-TE

Align the new carrier Ethernet with NGN frameworks

- It is about automating the service lifecycle (order through fulfillment), not about how you move the bits

Use the PBB-TE separation of control-and-data to create an Ethernet control plane designed expressly for NGN frameworks.

CEWC Interoperability PBB Demo

