



**Implementation Agreement
for
Integrated Polarization Multiplexed
Quadrature Modulated Transmitters**

IA # OIF-PMQ-TX-01.0

March 12, 2010

Implementation Agreement created and approved
by the Optical Internetworking Forum
www.oiforum.com



The OIF is an international non profit organization with over 90 member companies, including the world's leading carriers and vendors. Being an industry group uniting representatives of the data and optical worlds, OIF's purpose is to accelerate the deployment of interoperable, cost-effective and robust optical internetworks and their associated technologies. Optical internetworks are data networks composed of routers and data switches interconnected by optical networking elements.

With the goal of promoting worldwide compatibility of optical internetworking products, the OIF actively supports and extends the work of national and international standards bodies. Working relationships or formal liaisons have been established with IEEE 802.1, IEEE 802.3ba, IETF, IP-MPLS Forum, IPv6 Forum, ITU-T SG13, ITU-T SG15, MEF, ATIS-OPTXS, ATIS-TMOC, TMF and the XFP MSA Group.

For additional information contact:
The Optical Internetworking Forum, 48377 Fremont Blvd.,
Suite 117, Fremont, CA 94538
510-492-4040 ♦ info@oiforum.com

www.oiforum.com

Working Group: Physical and Link Layer (PLL) Working Group

TITLE: **Implementation Agreement for Integrated Polarization Multiplexed Quadrature Modulated Transmitters.**

SOURCE: TECHNICAL EDITOR

Martin Bouda, Ph.D.
Fujitsu Laboratories of America, Inc.
2801 Telecom Parkway
Richardson, TX 75093, USA
Phone: +1-972-479-2691
Email: martin.bouda@us.fujitsu.com

WORKING GROUP CHAIR

David R. Stauffer, Ph.D.
IBM Corporation
1000 River Road, MC 862J
Essex Jct., VT 05452, USA
Phone: +1-802-769-6914
Email: dstauffe@us.ibm.com

WORKING GROUP VICE CHAIR

Karl Gass
Sandia National Laboratories
P. O. Box 5800, MS-0874
Albuquerque, NM 87185, USA
Phone: +1-505-844-8849
Email: kgass@sandia.gov

ABSTRACT: This Implementation Agreement specifies key aspects of integrated polarization multiplexed quadrature modulated optical transmitters operating at rates up to 32GBd for applications such as 100G PM-QPSK DWDM transmission. This is not a multi-source agreement (MSA) but it is expected that it will serve as a foundation for future MSAs.

Notice: This Technical Document has been created by the Optical Internetworking Forum (OIF). This document is offered to the OIF Membership solely as a basis for agreement and is not a binding proposal on the companies listed as resources above. The OIF reserves the rights to at any time to add, amend, or withdraw statements contained herein. Nothing in this document is in any way binding on the OIF or any of its members.

The user's attention is called to the possibility that implementation of the OIF implementation agreement contained herein may require the use of inventions covered by the patent rights held by third parties. By publication of this OIF implementation agreement, the OIF makes no representation or warranty whatsoever, whether expressed or implied, that implementation of the specification will not infringe any third party rights, nor does the OIF make any representation or warranty whatsoever, whether expressed or implied, with respect to any claim that has been or may be asserted by any third party, the validity of any patent rights related to any such claim, or the extent to which a license to use any such rights may or may not be available or the terms hereof.

© 2010 Optical Internetworking Forum

This document and translations of it may be copied and furnished to others, and derivative works that comment on or otherwise explain it or assist in its implementation may be prepared, copied, published and distributed, in whole or in part, without restriction other than the following, (1) the above copyright notice and this paragraph must be included on all such copies and derivative works, and (2) this document itself may not be modified in any way, such as by removing the copyright notice or references to the OIF, except as needed for the purpose of developing OIF Implementation Agreements.

By downloading, copying, or using this document in any manner, the user consents to the terms and conditions of this notice. Unless the terms and conditions of this notice are breached by the user, the limited permissions granted above are perpetual and will not be revoked by the OIF or its successors or assigns.

This document and the information contained herein is provided on an "AS IS" basis and THE OIF DISCLAIMS ALL WARRANTIES, EXPRESS OR IMPLIED, INCLUDING BUT NOT LIMITED TO ANY WARRANTY THAT THE USE OF THE INFORMATION HEREIN WILL NOT INFRINGE ANY RIGHTS OR ANY IMPLIED WARRANTIES OF MERCHANTABILITY, TITLE OR FITNESS FOR A PARTICULAR PURPOSE.

1 Table of Contents

1	Table of Contents.....	4
2	List of Figures.....	5
3	List of Tables	5
4	Document Revision History.....	6
5	Introduction.....	7
6	Functionality	7
7	Electrical Interfaces.....	9
7.1	Functional and Mechanical Specification.....	9
8	Opto-Electronic Properties.....	12
9	Optical Properties.....	13
10	Environmental Conditions.....	13
11	Mechanical Properties.....	14
12	Test Methods and Definitions.....	15
13	Compliance.....	15
14	References	15
15	Appendix A: Glossary	16
16	Appendix B: Examples of Additional Mechanical Details	17
17	Appendix C: Open Issues.....	18
18	Appendix D: List of companies belonging to OIF when document was approved	19

2 List of Figures

FIGURE 1	FUNCTIONAL DIAGRAM OF A POLARIZATION MULTIPLEXED QUADRATURE MODULATED INTEGRATED TRANSMITTER WITH A DETAILED FUNCTIONAL DIAGRAM OF THE DATA MODULATOR.	7
FIGURE 2	MECHANICAL SPECIFICATION OF DC AND GPPO RF INTERFACES.	9
FIGURE 3	LOCATION OF THE DATUM AND ENVELOPE RELATED DIMENSIONS (TOP VIEW).	14
FIGURE B1	A SUBSET OF LOCATIONS OF POTENTIALLY EXISTING MOUNTING HOLES (BOTTOM VIEW)	17

3 List of Tables

TABLE 1	ELECTRICAL INTERFACE PIN-OUT AND FUNCTION WITH MULTIPLE OPTIONS FOR BIASING AND PHASE CONTROL.....	10
TABLE 1A	ALTERNATIVE ELECTRICAL INTERFACE PIN-OUT AND FUNCTION WITH MULTIPLE OPTIONS FOR BIASING AND PHASE CONTROL.	10
TABLE 2	LOW-SPEED INTERFACE ELECTRICAL PROPERTIES.	11
TABLE 3	ELECTRICAL AND OPTO-ELECTRONIC PROPERTIES.....	12
TABLE 4	OPTICAL PROPERTIES.	13
TABLE 5	ENVELOPE TYPE FEATURES AND DIMENSIONAL PARAMETERS IN MM	14

4 Document Revision History

Working Group: Physical and Link Layer (PLL) Working Group

SOURCE: TECHNICAL EDITOR

Martin Bouda, Ph.D.
Fujitsu Laboratories of America, Inc.
2801 Telecom Parkway
Richardson, TX 75093, USA
Phone: +1-972-479-2691
Email: martin.bouda@us.fujitsu.com

WORKING GROUP CHAIR

David R. Stauffer, Ph.D.
IBM Corporation
1000 River Road, MC 862J
Essex Jct., VT 05452, USA
Phone: +1-802-769-6914
Email: dstauffe@us.ibm.com

WORKING GROUP VICE CHAIR

Karl Gass
Sandia National Laboratories
P. O. Box 5800, MS-0874
Albuquerque, NM 87185, USA
Phone: +1-505-844-8849
Email: kgass@sandia.gov

DATE: **March 12th, 2010**

Revision 1.0 OIF-PMQ-TX-01.0 created out of oif2009.186.05 on March 12, 2010.

5 Introduction

This document details an Implementation Agreement (IA) for an optical integrated Polarization Multiplexed (PM) quadrature modulated transmitter for applications with nominal symbol rates of up to 32GBaud. While specifically addressing 100G PM-QPSK applications with FEC, this Implementation Agreement strives to remain modulation format and data rate agnostic whenever practical to maximize applicability to other future applications. This IA is expected to serve as a foundation for future MSAs.

6 Functionality

This Implementation Agreement specifies in detail a single opto-electronic module with the functionality contained in the yellow area enclosed by the bold line in Figure 1. This module will be referred to as Polarization Multiplexed-Quadrature Modulator or PM-Q Modulator.

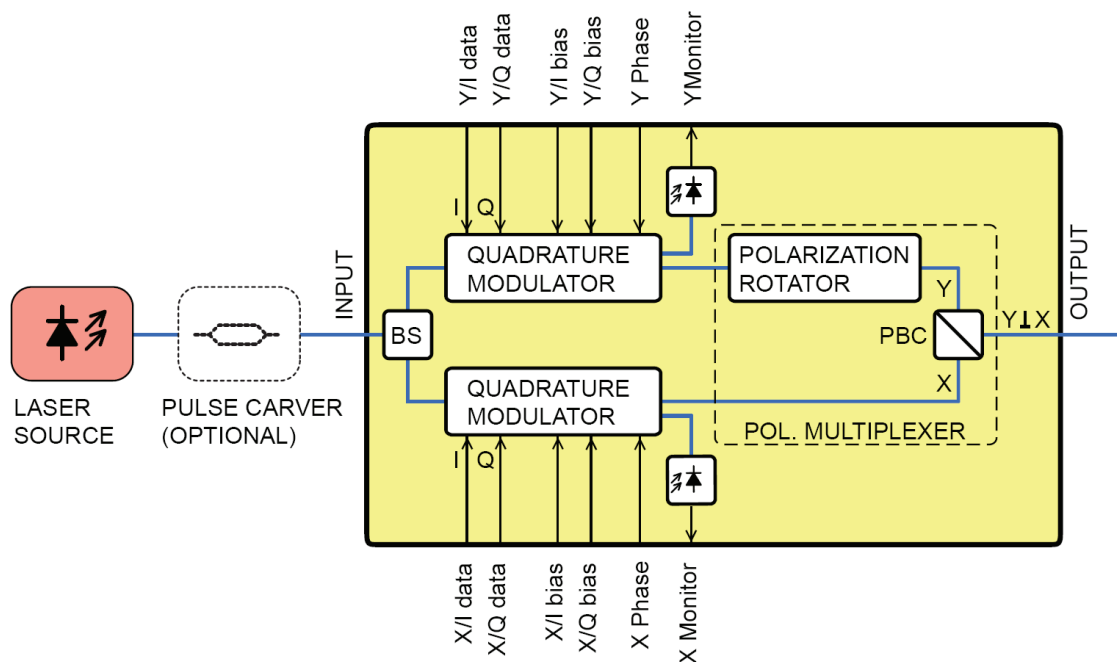

Figure 1 Functional diagram of a polarization multiplexed quadrature modulated integrated transmitter with a detailed functional diagram of the data modulator.

The optical power from an input fiber is divided into two parts and each part is independently modulated by a quadrature modulator. The resulting two modulated signals are combined with their polarizations orthogonal to each other, and output through an optical output fiber. The power in each of the two polarizations is independently monitored with photodiodes.

The quadrature modulators typically comprise two nested Mach-Zehnder modulators with bias control, a 90° phase shifter in the outer modulators with phase control, and an output power monitoring output. Any implementation or technology choices may be used to realize the same basic functionality.

As indicated in Figure 1, the PM-Q Modulator includes the following basic functional components:

- One optical input
- One optical power splitter
- Two independent quadrature modulators
- Two independent monitoring photodiodes
- One polarization multiplexer
- One optical output

The PM-Q Modulator module specified in this Implementation Agreement does not include drivers or any control electronics.

The following independent interfaces are specified for the PM-Q modulator:

- One optical input fiber
- One optical output fiber
- Four high-speed data interfaces
- Four modulator bias control interfaces
- Two phase control interfaces
- Two power monitoring interfaces

The two polarized components at the output are referred to as “X” and “Y”, and the arms in which information is modulated onto the polarization component are correspondingly referred to as X and Y arms. Each quadrature modulator is driven by an “I” and a “Q” data signal. The four high-speed data interfaces are referred to as X/I, X/Q, Y/I and Y/Q data interfaces. Nominal phase shifts in the quadrature modulators between I and Q shall be the same in X and Y arms.

Each of the four data modulators needs to be biased with a suitable DC voltage. This IA specifies biasing pins supporting both single-ended as well as push-pull biasing. The naming of the bias pins is consistent with the naming of the high-speed data interfaces. The I and Q phase offset is controlled via phase control pins also supporting both single-ended as well as push-pull control. The phase offset between I and Q in X and Y arms is controlled by phase control interfaces X Phase and Y Phase respectively.

7 Electrical Interfaces

7.1 Functional and Mechanical Specification

The high-speed data interfaces of the PM-Q Modulator module shall be coaxial GPPO-compatible interfaces. The mechanical specification with four in-wall male GPPO high-speed interfaces and 18 low-speed pins is shown in Figure 2. The distance S between low-speed pins and the high-speed interfaces is defined in Table 5 and referenced to the datum shown in the figure, centered between the center lines of the high-speed connectors. The low-speed pins are grouped in groups of 6 pins. The type of the low-speed pins, their length and their distance from the bottom plane of the modulator package are not specified.

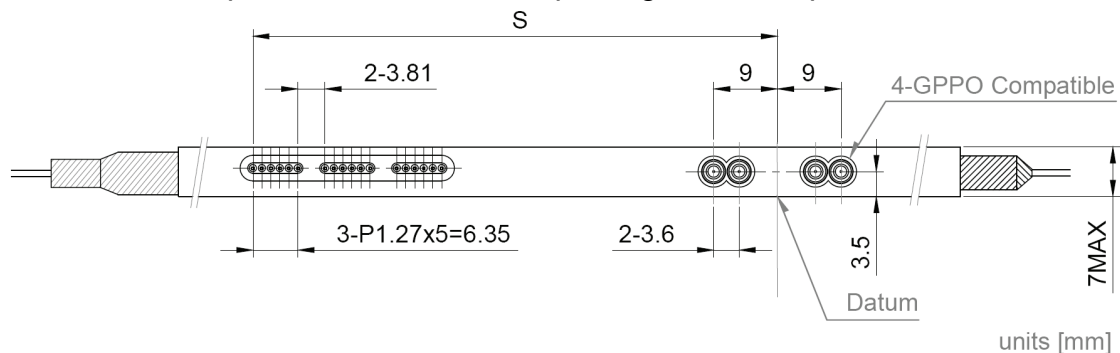

Figure 2 Mechanical specification of DC and GPPO RF interfaces.

The pin numbering starts with the first high-speed data interface connector furthest from the DC pins and the pin number increases towards the opposite side. A first electrical interface grouping, ordering and function are listed in Table 1. An alternative allowed electrical interface ordering is provided in Table 1a. The alternative ordering in Table 1a interleaves corresponding X and Y polarization quadrature bias pins to minimize the electrical crosstalk between the I and Q modulator biases. The separation between the monitor photodiode cathodes is also maximized with this alternative ordering for crosstalk reasons.

Table 1 Electrical interface pin-out and function with multiple options for biasing and phase control.

Pin	Symbol		Description
1	Data_X/I		X-polarization in-phase data input
2	Data_X/Q		X-polarization quadrature data input
3	Data_Y/I		Y-polarization in-phase data input
4	Data_Y/Q		Y-polarization quadrature data input
5	Bias_Y/Q(p)	Bias_Y/Q	Y/Q modulator (positive) bias
6	Bias_Y/Q(n)	GND or NC	Y/Q modulator neg. bias (push-pull) or GND or NC (single-ended)
7	Bias_Y/I(p)	Bias_Y/I	Y/I modulator (positive) bias
8	Bias_Y/I(n)	GND or NC	Y/I modulator neg. bias (push-pull) or GND or NC (single-ended)
9	Bias_X/Q(p)	Bias_X/Q	X/Q modulator (positive) bias
10	Bias_X/Q(n)	GND or NC	X/Q modulator neg. bias (push-pull) or GND or NC (single-ended)
11	Bias_X/I(p)	Bias_X/I	X/I modulator (positive) bias
12	Bias_X/I(n)	GND or NC	X/I modulator neg. bias (push-pull) or GND or NC (single-ended)
13	Phase_Y(p)	Phase_Y	Y pol. phase (positive)
14	Phase_Y(n)	GND or NC	Y pol. phase negative (push-pull) or GND or NC (single-ended)
15	Phase_X(p)	Phase_X	X pol. phase (positive)
16	Phase_X(n)	GND or NC	X pol. phase negative (push-pull) or GND or NC (single-ended)
17	NC		Not Connected
18	Y_A		Y-polarization photodiode Anode
19	Y_C		Y-polarization photodiode Cathode
20	GND		Ground
21	X_C		X-polarization photodiode Cathode
22	X_A		X-polarization photodiode Anode

Table 1a Alternative electrical interface pin-out and function with multiple options for biasing and phase control.

Pin	Symbol		Description
1	Data_X/I		X-polarization in-phase data input
2	Data_X/Q		X-polarization quadrature data input
3	Data_Y/I		Y-polarization in-phase data input
4	Data_Y/Q		Y-polarization quadrature data input
5	Bias_Y/Q(p)	Bias_Y/Q	Y/Q modulator (positive) bias
6	Bias_Y/Q(n)	GND or NC	Y/Q modulator neg. bias (push-pull) or GND or NC (single-ended)
7	Bias_X/Q(p)	Bias_X/Q	X/Q modulator (positive) bias

8	Bias_X/Q(n)	GND or NC	X/Q modulator neg. bias (push-pull) or GND or NC (single-ended)
9	Bias_Y/I(p)	Bias_Y/I	Y/I modulator (positive) bias
10	Bias_Y/I(n)	GND or NC	Y/I modulator neg. bias (push-pull) or GND or NC (single-ended)
11	Bias_X/I(p)	Bias_X/I	X/I modulator (positive) bias
12	Bias_X/I(n)	GND or NC	X/I modulator neg. bias (push-pull) or GND or NC (single-ended)
13	Phase_Y(p)	Phase_Y	Y pol. phase (positive)
14	Phase_Y(n)	GND or NC	Y pol. phase negative (push-pull) or GND or NC (single-ended)
15	Phase_X(p)	Phase_X	X pol. phase (positive)
16	Phase_X(n)	GND or NC	X pol. phase negative (push-pull) or GND or NC (single-ended)
17	NC		Not Connected
18	Y_C		Y-polarization photodiode Cathode
19	Y_A		Y-polarization photodiode Anode
20	GND		Ground
21	X_A		X-polarization photodiode Anode
22	X_C		X-polarization photodiode Cathode

The electrical properties related to the power monitor diodes are specified in Table 2. The opto-electronic properties of the optical modulator including the high-speed data interfaces are specified in Section 8.

Table 2 Low-speed interface electrical properties.

Parameter	Unit	Min.	Typ.	Max.	Remarks
Monitor PD Responsivity	mA/W	ffs		ffs	
Monitoring PD O/E Bandwidth	GHz	1			

8 Opto-Electronic Properties

Electrical specification of the high-speed interface and opto-electronic properties are given in Table 3 at the end of life over the operating temperature and frequency ranges.

Table 3 Electrical and opto-electronic properties.

Parameter	Unit	Min.	Typ.	Max.	Remarks
S21 E/O Bandwidth (3dB)	GHz	23			3% smoothed, reference frequency at 1.5GHz or 2GHz
S11 Electrical Return Loss f ≤ 25 GHz 25 < f ≤ 32 GHz	dB	10 8			
Vpi_PRBS	V			3.5	Specified at PRBS31 at 32 GBd
Vpi_LF (*1)	V			3.4	Measured at 1.5GHz or 2GHz
RF Impedance	Ohm		50		
I/Q skew (*2)	ps			4	For each polarization component
Total skew (*3)	ps			10	
I/Q skew variation	ps			2	
Total skew variation	ps			5	
1) A module vendor shall provide data showing correlation between Vpi_LF and Vpi_PRBS, and specify a Vpi_LF that guarantees a Vpi_PRBS satisfying the requirements in this table. 2) I/Q Skew is the skew between channel pairs X/I and X/Q, and Y/I and Y/Q. 3) Total skew is the maximum skew between any of the four physical channels X/I, X/Q, Y/I and Y/Q.					

Skew is defined as the maximum signal propagation time difference between physical signal channels, between electrical input and optical output interfaces. Skew includes any skew variation due to aging, temperature and any other effects.

9 Optical Properties

Optical properties of the optical modulator are listed in Table 4 at the end of life over the operating temperature and frequency ranges.

Table 4 **Optical properties.**

Parameter	Unit	Min.	Typ.	Max.	Remarks
Operating Frequency C-Band L-Band	THz	191.35 186.0		196.2 191.5	At least one range shall be supported in one device
Input power	dBm			18	Peak power
Insertion loss	dB	ffs		14	All modulators at peak transmission, for each polarization
Insertion loss difference between X and Y				ffs	
Optical return loss	dB	30			Input and output
Parent MZI ER	dB	20			
Child MZI ER	dB	20			
Polarization ER	dB	20			

In case of polarization maintaining fiber, the optical connector key shall be aligned to the slow axis of the polarization maintaining fiber. The input fiber shall be polarization maintaining. Optical and opto-electronic specifications assume that a polarized input signal is launched into the slow axis of the input fiber.

The output fiber shall be either SMF or PMF.

10 Environmental Conditions

The typically expected operating temperature range is -5°C to +75°C. For the purpose of uniform calculation of the Failures In Time (FIT) rate, a fielded temperature of 55°C shall be used.

11 Mechanical Properties

The dimensions of mechanical envelopes depend on the application. Envelope parameters are defined in Figure 3. A reference point or datum is used to reference the extent of the envelopes, as well as the location of all electrical interfaces.

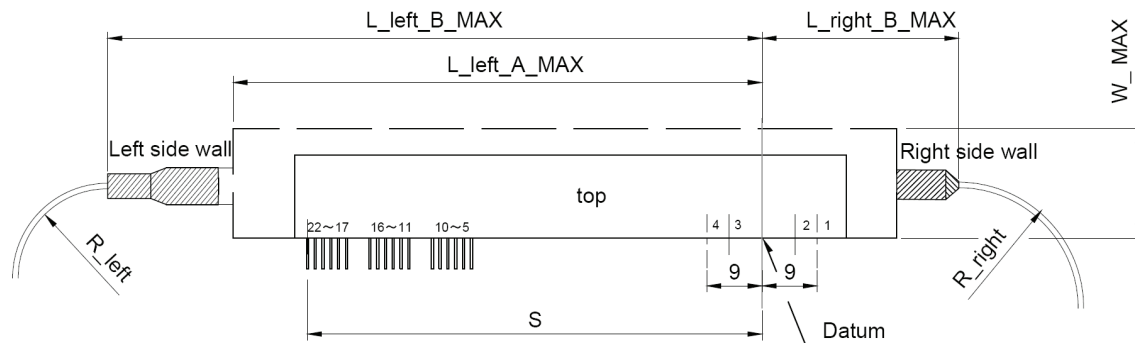

Figure 3 Location of the datum and envelope related dimensions (top view).

Bend radii and boot lengths are not explicitly specified to avoid restricting the choice of implementation or technology. Three envelopes are specified in Table 5. Envelope Type 3 is reserved for future, more compact transmitters.

Table 5 Envelope type features and dimensional parameters in mm.

Parameter	Type 1	Type 2	Type 3
Input fiber side wall	right	right	any
Output fiber side wall	left	right or left	any
Mounting hole side	bottom	bottom	bottom
S	74.06	74.06	ffs
L_right_B_MAX	36.0	51.1	ffs
L_left_A_MAX		88.5	ffs
L_left_B_MAX for R_right =20mm for R_right =15mm	98.8 103.8		
W_MAX	13.5	20.0	ffs
H_MAX	7	7	7

Mounting holes shall be of type M2.

12 Test Methods and Definitions

13 Compliance

14 References

15 Appendix A: Glossary

AC	Alternating Current
BS	Beam Splitter
BW	Band Width
DC	Direct Current
E/O	Electro-Optical
ER	Extinction Ratio
FEC	Forward Error Correction
FIT	Failures In Time
ffs	for further study
GNC	Ground
IA	Implementation Agreement
PBC	Polarization Beam Combiner
PD	Photo Diode
PMF	Polarization Maintaining Fiber
PM-Q	Polarization Multiplexed Quadrature
QPSK	Quadrature Phase Shift Keying
RF	Radio Frequency
SMF	Single Mode Fiber
MSA	Multi-Source Agreement
MZI	Mach-Zehnder Interferometer
NC	Not Connected

16 Appendix B: Examples of Additional Mechanical Details

This Appendix is informational and intended to avoid incompatible placement of alternate mounting holes and to provide other informative information that may be useful.

Three mounting hole placement options are suggested in the area between the low-speed and high-speed electrical interfaces, along the side wall with the electrical interfaces. Other holes will exist. At least one additional mounting hole shall be located at the side opposite the electrical interfaces.

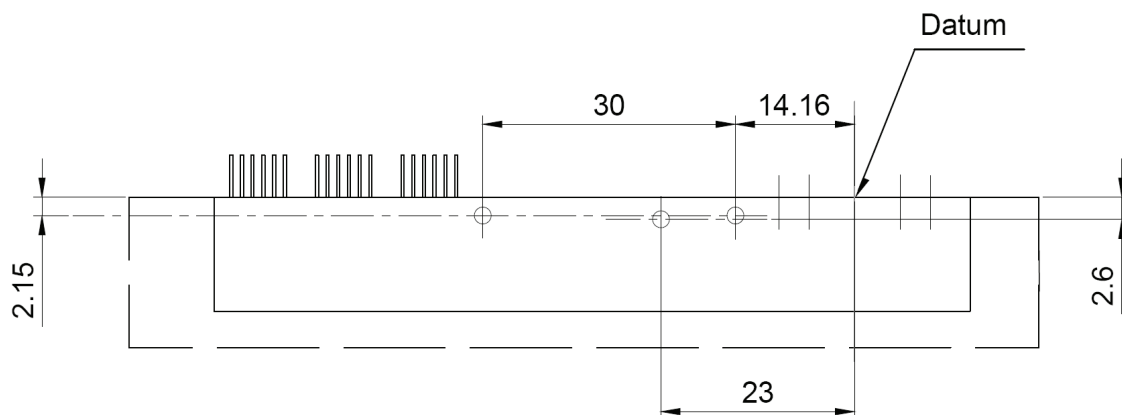

Figure B1 A subset of locations of potentially existing mounting holes (bottom view).

Boot lengths may vary from 21.2mm to 10.3mm depending on implementation.

17 Appendix C: Open Issues

The following items may require more study and could be included in future revisions of this IA.

- Insertion loss wavelength dependency
- X/Y orthogonality
- Responsivity of power monitors
- Bias voltage ranges
- Phase control range
- DC pin lead dimensions
- Output and input fiber position (plane or point)
- Heatsink mounting considerations
- Actual practical operating temperature range
- Measurement methods
- Common mounting holes
- Small form factor modulators
- Other RF interface options
- Crosstalk between RF data and the monitoring PD

18 Appendix D: List of companies belonging to OIF when document was approved

Acacia Communications	JDSU
ADVA Optical Networking	Juniper Networks
Alcatel-Lucent	KDDI R&D Laboratories
Altera	LSI Corporation
AMCC	Luxtera
Analog Devices	Marben Products
AT&T	Metaswitch
Avago Technologies Inc.	Mintera
Avalon Microelectronics	MITRE Corporation
Broadcom	Mitsubishi Electric Corporation
Brocade	Molex
Centellax, Inc.	NEC
China Telecom	NeoPhotonics
Ciena Corporation	Nokia Siemens Networks
Cisco Systems	Nortel Networks
ClariPhy Communications	NTT Corporation
Cogo Optronics	Oclaro
Comcast	Ofidium
CoreOptics	Opnext
Cortina Systems	Optametra
CyOptics	Optoplex
Dell, Inc.	Picometrix
Department of Defense	PMC Sierra
Deutsche Telekom	Proximion Fiber Systems AB
Emcore	Sandia National Laboratories
Ericsson	Sanmina-SCI
Ethos Networks	Santur
ETRI	Sierra Monolithics
EXFO	ST Microelectronics
Fiberhome Technologies Group	Sumitomo Electric Industries
Finisar Corporation	Sumitomo Osaka Cement
Force 10 Networks	Sycamore Networks
France Telecom	Tektronix
Fujitsu	Telcordia Technologies
Furukawa Electric Japan	Telecom Italia Lab
Gennum Corporation	Tellabs
GigOptix Inc.	TeraXion
Hitachi	Texas Instruments
Huawei Technologies	Time Warner Cable
IBM Corporation	TPACK A/S
Infinera	TriQuint Semiconductor
Inphi	Tyco Electronics
IP Infusion	u2t Photonics AG



Verizon
Vitesse Semiconductor
Xilinx
Yamaichi Electronics Ltd.
ZTE Corporation

OIF-PMQ-TX-01.0