

Converged Carrier Ethernet Transport Opportunity and Challenges

Feb. 4th, 2008

Shinya Nakamura, NEC Corporation of America

Kunihiro Ishiguro, IP Infusion Inc.



OIF

OPTICAL
INTERNETWORKING
FORUM

Agenda

- **General networking issues**
 - **Optical/Packet transport network**
 - **Services requirements and issues**
- **A view from “Transport ”**
- **A view from “Packet ”**
- **Vision of a simplified layer structure and network migration**
- **Unified management**
- **Conclusion**

Services requirements

- ◆ **End users**
 - **Packet services with packet multiplexing/Statistical multiplexing**
“It must be cheap.”
 - **While maintaining level of services, lower the running cost.**
 - **Ethernet VPN, IP-VPN, IP phone, Internet access, etc..**
- ◆ **MPLS is widely deployed for core and wide area network services**
 - **IP over MPLS, Ethernet over MPLS**
 - **Guarantee the packet level quality using Packet multiplexing and QoS/priority control**
 - **There are still issues on MPLS ... (Scalability, Inter domain, etc)**

Strong demand of lower cost and high reliability

Requirements is simple : the same level of quality as existing telephone and private line services

Networking Issues

- ◆ **Everything is transported over packet**
 - **IPTV services**
 - **Consumer video distribution**
 - **IP migration of Mobile Network (3G、LTE)**
- ◆ **Many existing technologies and architectures**
 - **Merger of carriers**
 - **Service trends**
 - **Interoperability**
 - **Forum standards work overlap**
 - **Domain transparency**
- ◆ **Problems of the internet based packet network technology**
 - **End to end performance and quality management**
 - **Reliability of the node(s)**
 - **Complex OAM, especially for the large scale network**
 - **Scalability**
- ◆ **The new transport and aggregation for the new Packet infrastructure**
 - **'Post SONET/SDH'**
 - **Between WDM transport and IP**
 - **Ethernet evolution for transport**

A view of "Transport "

Management of Optical/IP network

Visible vs Invisible

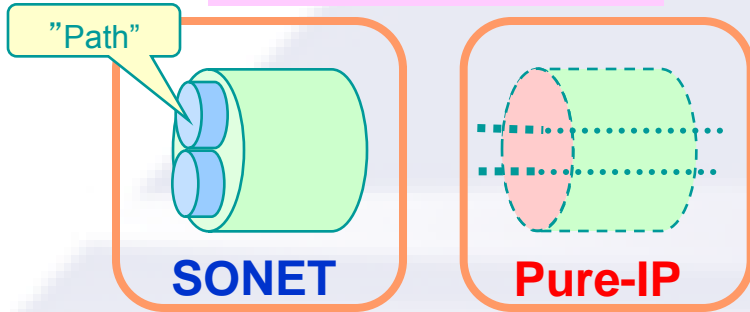

The same management method for any types of traffic

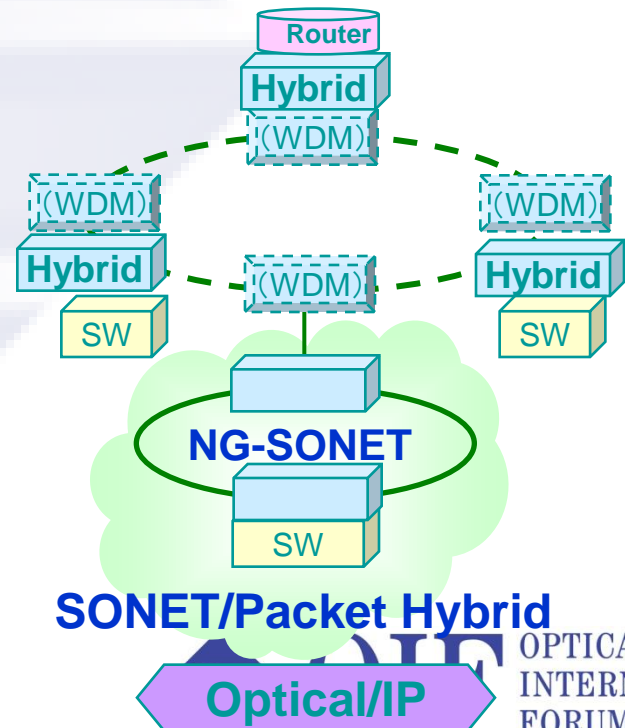
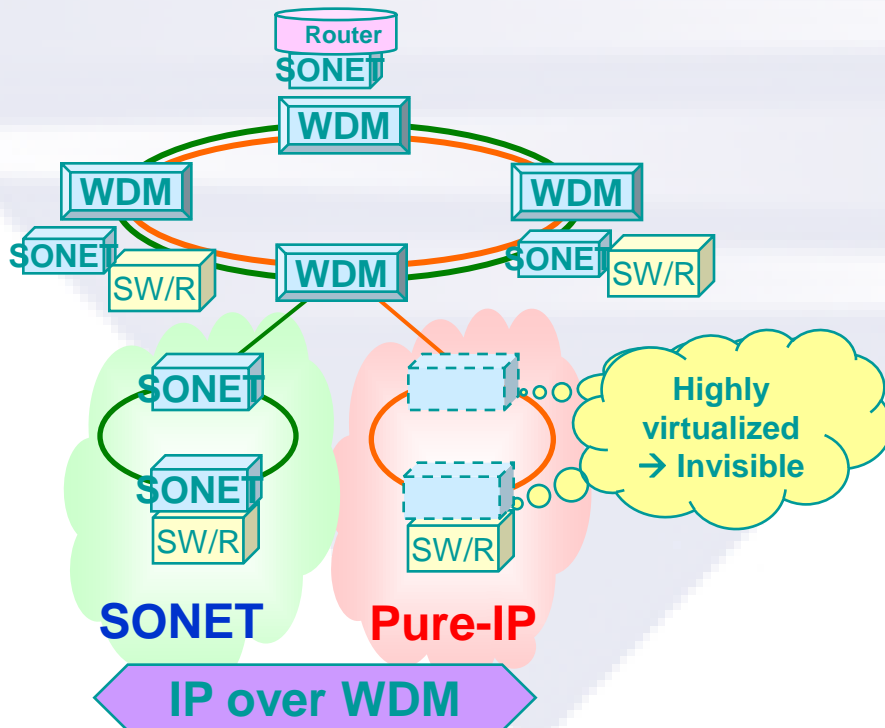
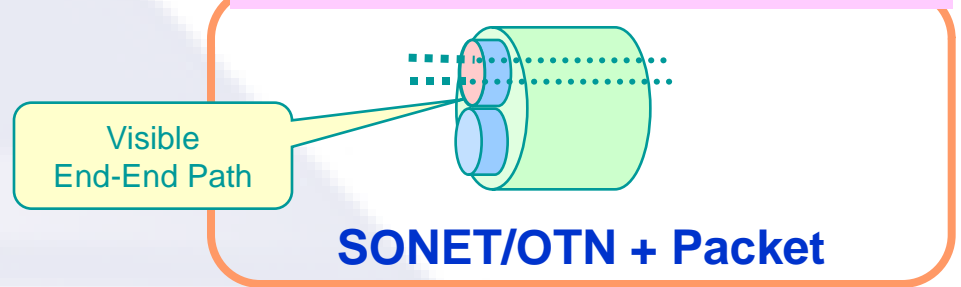

Convergence of Transport World and Packet World

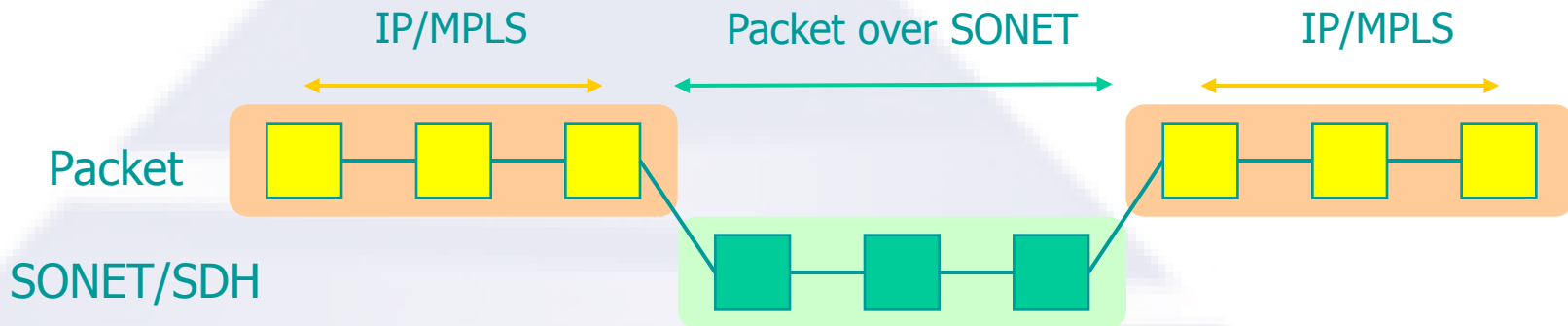

- ◆ Today Packet world and Transport world are completely separated
- ◆ Carrier has two different operational team one for packet one for transport
- ◆ With overlay technology such as Packet over SONET are required to connect these two different world
- ◆ Management system is also different CLI v.s. EMS/NMS

Convergence of Transport World and Packet World(2)

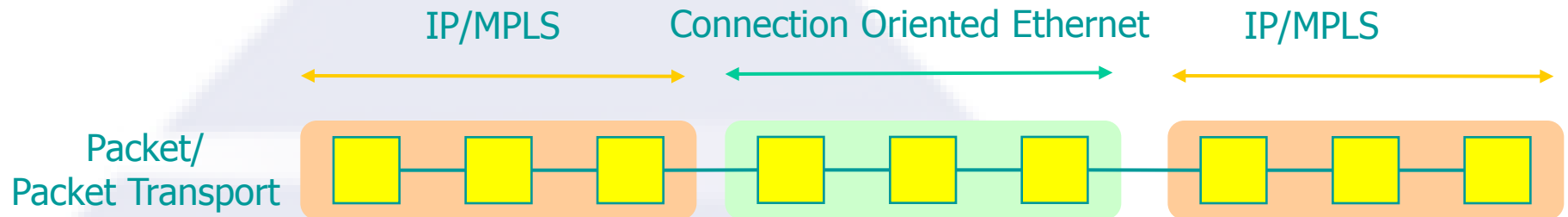

- ◆ **With Packet Transport technology, we can converge Transport World and Packet World**
- ◆ **We want to leverage both world's best feature**
- ◆ **Stability and solid management and QoS from Transport World**
- ◆ **Flexible bandwidth granularity and dynamic routing from Packet World**

Complex Layer Structure

- ◆ We have been adding new header every time when new service is introduced to network
- ◆ L3 routing is the foundation of all of network services even if we use MPLS
- ◆ Are we going to add some more?
- ◆ Are we adding a new layer?

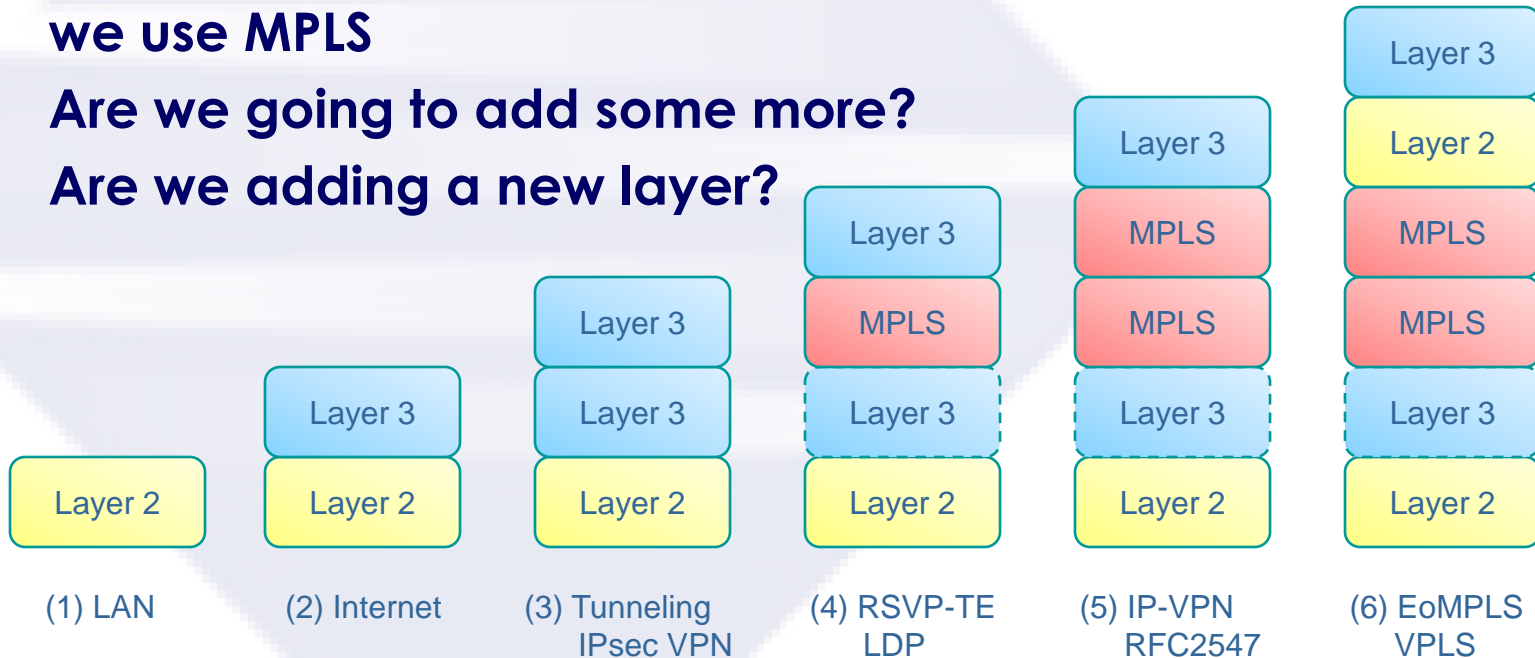

As numbers of header grows, stability/performance/reliability decrease

Source: Mr. Ishiguro, Keynote presentation, JANOG2007

Vision of a Simplified Layer Structure

- ◆ **PBB-TE (Provider Backbone Bridge-Traffic Engineering) with MPLS interworking**
 - **Migration and integration of Ethernet services network**
 - **Realizes high quality, scalable VPN services**
 - **VPLS (Virtual Private LAN Service) with nation wide scalability**
 - **The new convergence layer between WDM and IP**

- ✓ The header structure is very simple
- ✓ There is no dependencies to L3 routing such as OSPF/IS-IS

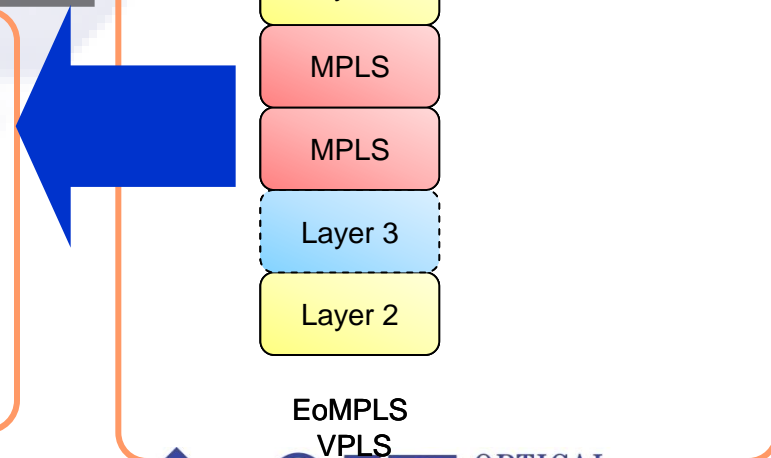
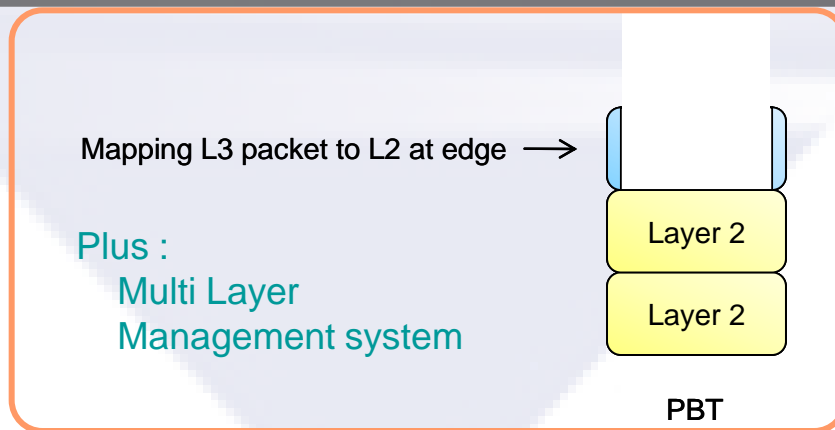

Simplify the header

Carrier Scaling Ethernet and Transport Migration

- ◆ Transport technology migrates from TDM to packet.
- ◆ However, SONET/OTN is still important, providing transparent transport with rich OAM features.
- ◆ Key technologies:
 - Hybrid packet and TDM switching
 - Unified multilayer management
 - Interworking with existing IP/MPLS

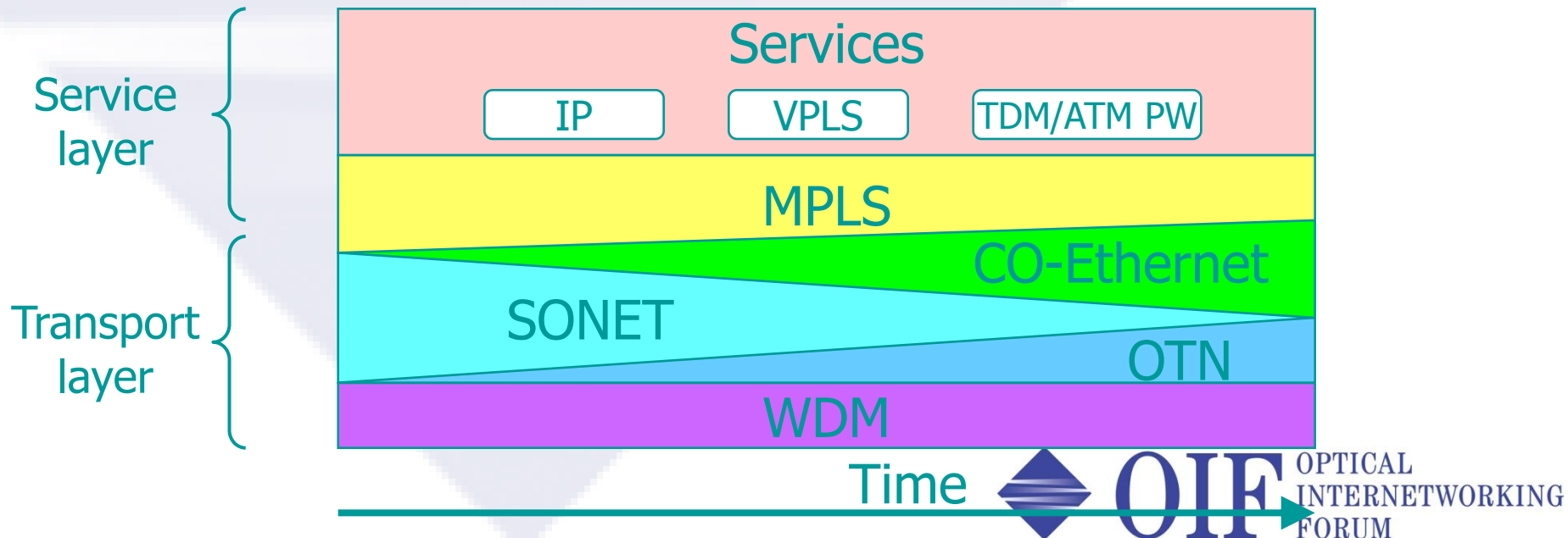

Interworking with IP/MPLS

- ◆ **ISSUE:**
the interwork with existing IP/MPLS routers through normal MPLS signaling.

Overlay Model

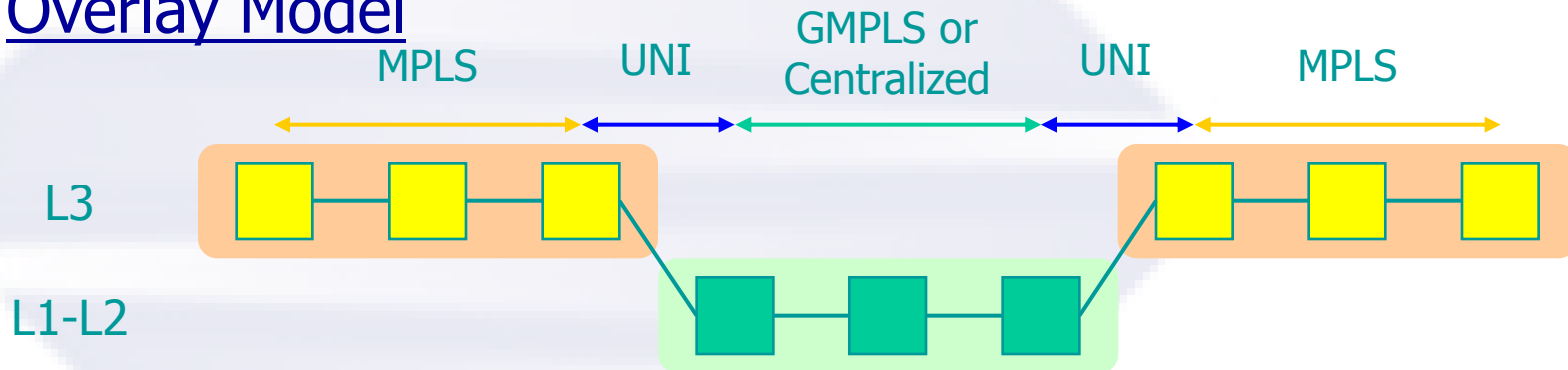

MPLS and GMPLS/GELS Interworking

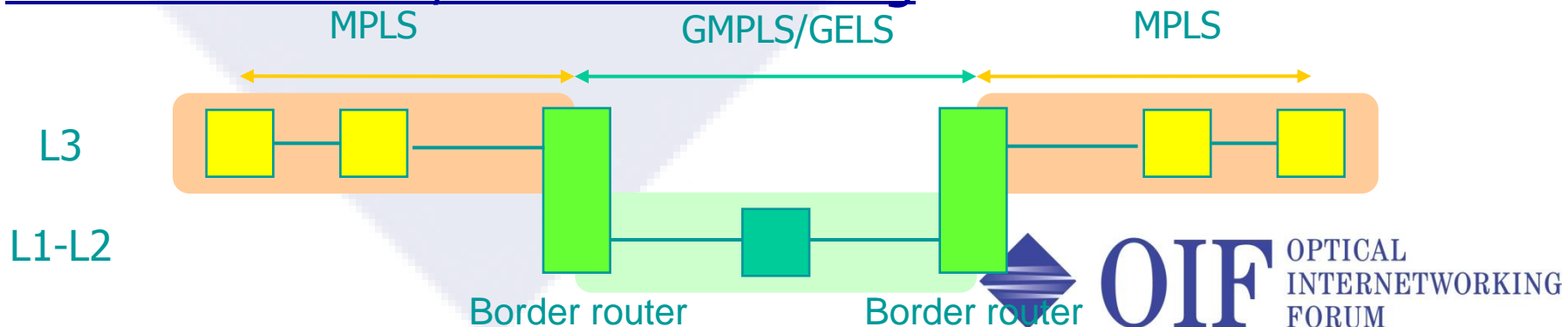

Unified Multilayer Management

- ◆ **Unified view and operation for all the layers.**

- **Point and click provisioning**
- **Fault localization**
- **Root cause analysis**
- **Protection/restoration**

- ◆ **Interworking among layers**

- **Inter-layer traceability**
- **Dynamic network engineering**
 - **Optimization of virtual links = lower layer path**
- **Option for independent management of layers**

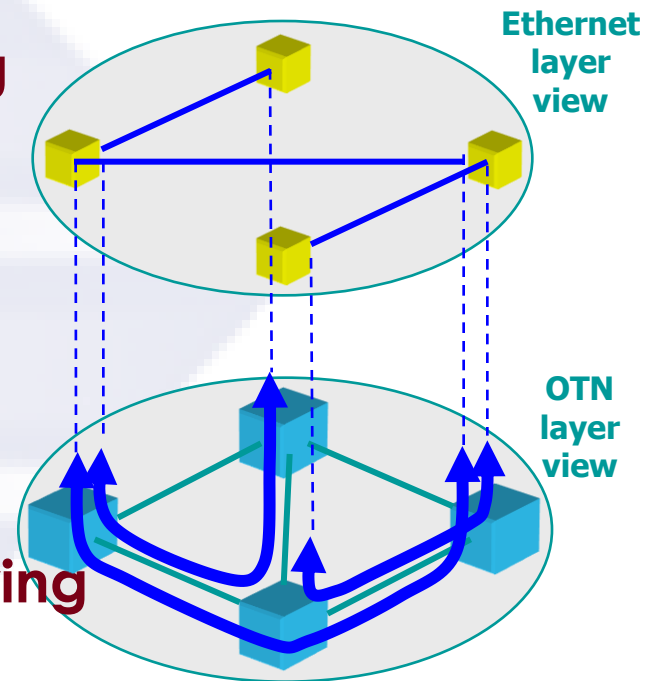

Lower layer paths are seen as higher layer virtual links

Centralized management system vs Distributed system

•Issues

- NMS centralized Database vs Distributed control
- Path configuration and Protection/Restoration
- Transport system : Historically centralized
- IP/MPLS system : Distributed but TE engineers' nightmare

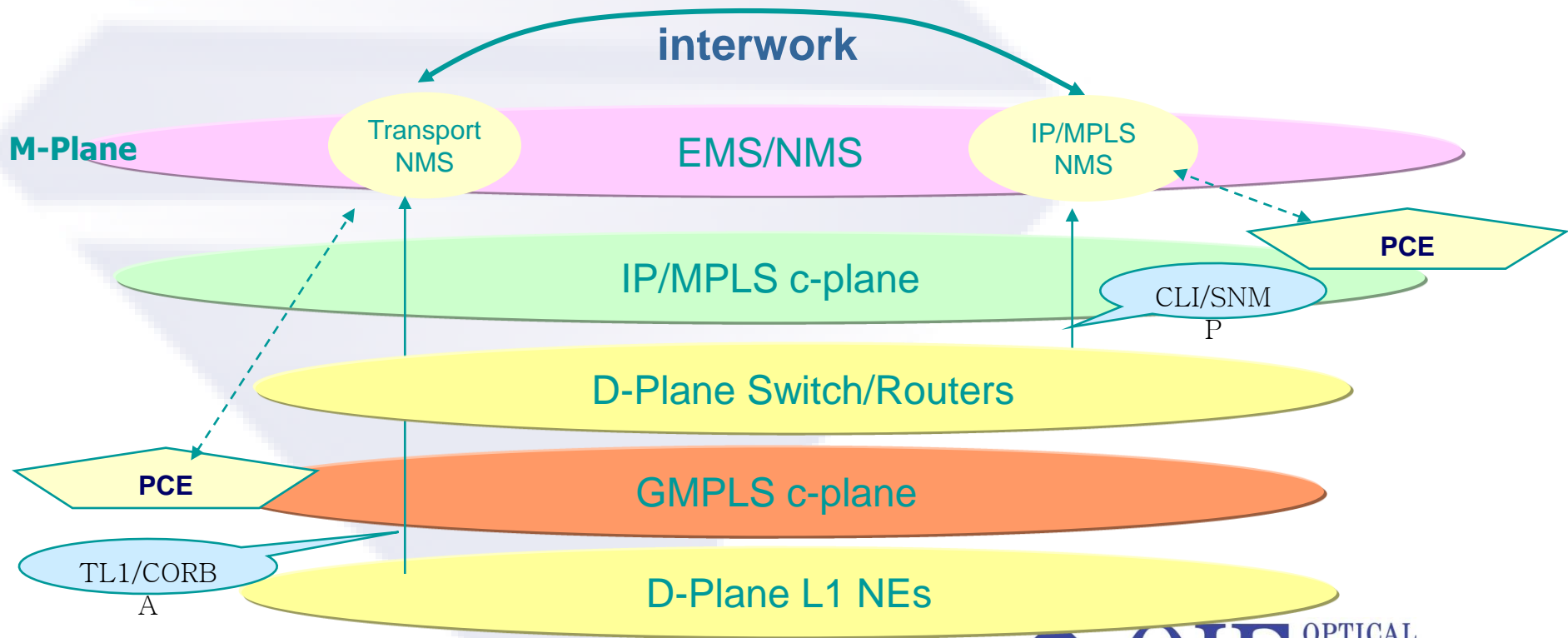

Ethernet is coming to the “transport” world

SONET world

Pros

- **Connection path is provisionable/visible**
- **Guaranteed quality (No information discarded)**

Cons

- **High network cost**

Packet world

Pros

- **Low network cost (LAN based)**
- **Well fit with trend toward packet network**

Cons

- **Connection path is not provisionable/visible**

Connection-Oriented Ethernet Ethernet with Transport-like Management

- **Connection path provisionable**
- **Ethernet OAM**



Conclusion

- ◆ All services will be converged into IP/Packet → All IP Network
- ◆ All IP Network does not imply all NE's are IP routers
- ◆ Next Generation Network
 - Realizes efficient packet aggregation and reliable transmission
 - Traffic aggregation towards the core and edge routers
 - Scalable for high speed/high capacity traffic
 - Manageable as end to end path

Carrier scaling Ethernet and optical transmission can provide end to end path monitoring and path/link fault localization Over the packet based network

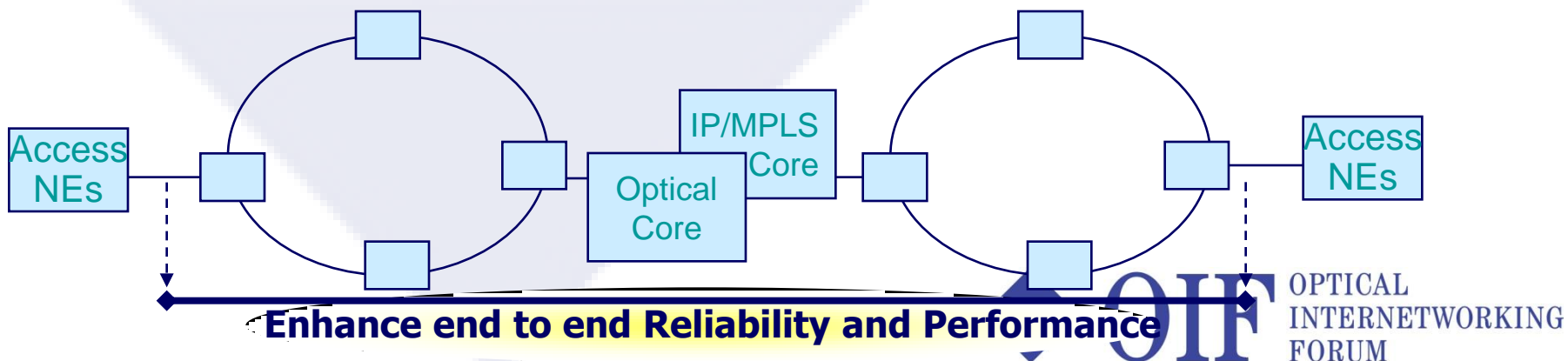

- ◆ **Thank you!**