

Meeting the Need for Speed – 40G/100G

*Discussing recent developments of 100G work within
the OIF*



IIR Transport Network Strategies
November 18, 2008
Barcelona, Spain

Ghani Abbas, Ericsson



Outline

- ◆ **OIF Meets the Need for Speed thru Implementation Agreements**
- ◆ **Drivers for 40GE/100GE Services**
- ◆ **Diverse Applications**
- ◆ **Market Discussions**
- ◆ **OIF Activities**

The OIF Meets the Need for Speed Thru Implementation Agreements

- ◆ Electrical Interfaces
- ◆ Optical Transponder Interoperability
- ◆ Tunable Laser
- ◆ UNI-NNI
- ◆ Very Short Reach Interface
- ◆ Benchmarking
- ◆ Hardware
- ◆ Software
- ◆ Optical Transport Network (OTN)

Bandwidth drivers – Triple play

Broadband access

The digital home



Triple Play



The data capacity required for 30 minutes of TV viewing is equivalent to 30 days of typical internet surfing

Source: Various contributions from IEEE802.3ba work during developing the objectives and market potential.

Broadband Access Fixed Access Traffic Growth

Global subscriber access traffic

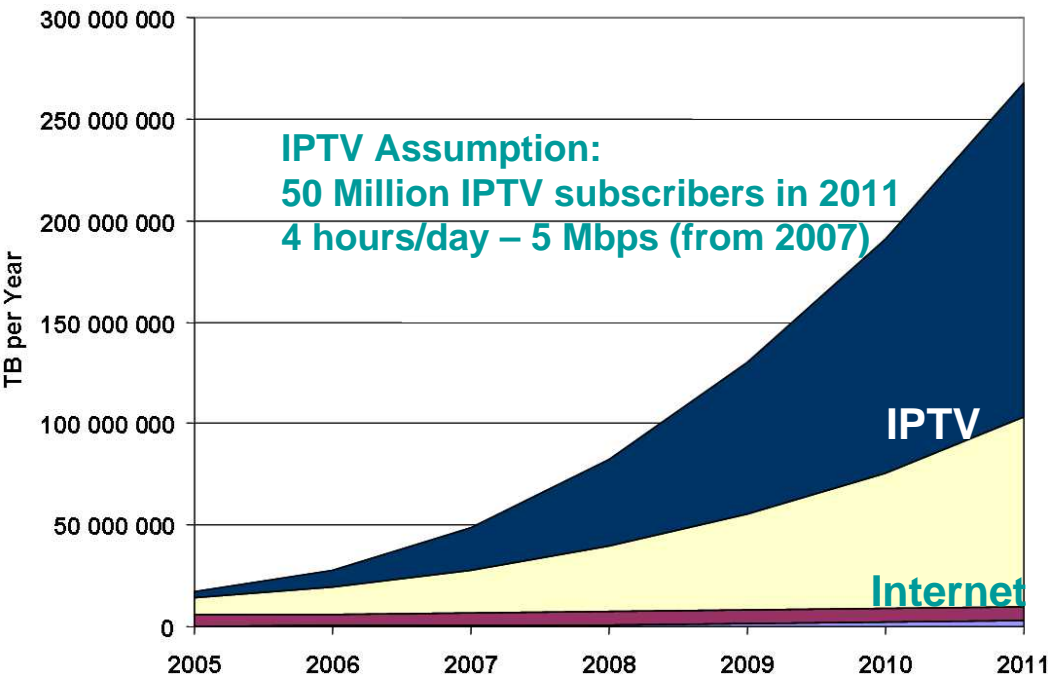

Access traffic growth through increased:

- **broadband penetration**
- **bandwidth demanding services**

Service	Bandwidth*
VoIP	100 kbps
IMS/Video conf	0.7 - 1.5 Mbps
Internet	0.2 - 5.0 Mbps
Gaming	0.2 - 0.5 Mbps
SDTV (MPEG-2)	6 Mbps
SDTV (MPEG-4)	3 Mbps
HDTV (MPEG-2)	20 Mbps
HDTV (MPEG-4)	10 Mbps

*Delivered capacity

Typical service portfolio (2010):

1 HDTV, 2 SDTV, gaming, voice, high-speed internet → 25 – 30 Mbps (MPEG-4)

Source: Various contributions from IEEE802.3ba work during developing the objectives and market potential.

Application areas 100GbE Ethernet ecosystem

Consumer Broadband Access



Aggregation, CATV
10-40km
Need 100G: 2010

The diagram shows a cloud containing icons for a wireless antenna, a television, a computer monitor, and a mobile phone. A yellow callout box is overlaid on the cloud.

Content Providers



Google, Yahoo!, etc
400m – 2km
Need 100G: Today

The diagram shows a cloud containing server rack icons. A yellow callout box is overlaid on the cloud.



Transport Networks
100GbE over OTN
10 – 1500km
Need: 2010

The diagram shows a central cloud with a router icon. A yellow callout box is overlaid on the cloud.



Enterprise Networks

The diagram shows a cloud containing a server rack icon and a router icon.



Research and Government
LB Labs, LL Labs, etc
<100m, <2km
Need 100G: 2011

The diagram shows a cloud containing a globe icon. A yellow callout box is overlaid on the cloud.

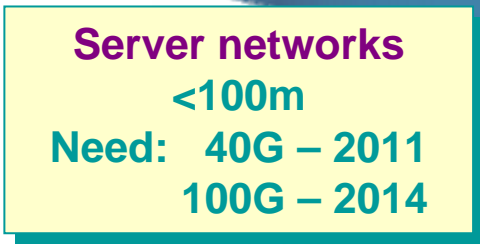

Server networks
<100m
Need: 40G – 2011
100G – 2014

The diagram shows a cloud containing a server rack icon. A yellow callout box is overlaid on the cloud.

Centers and
rise

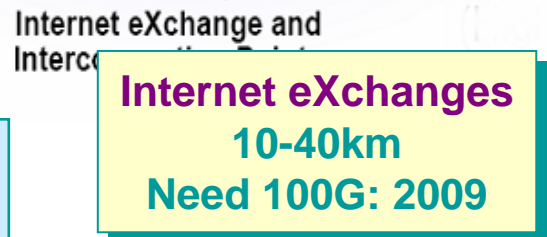

Internet eXchanges
10-40km
Need 100G: 2009

The diagram shows a cloud containing a router icon. A yellow callout box is overlaid on the cloud.

Source: Various contributions from IEEE 802.3ba work during developing the objectives and market potential.

100GE Market

Recent Survey (Heavy Reading Nov. 2007) indicates:

- ◆ 10-15% of operators stated immediate need for 100G
- ◆ Key years for deployment will be 2010-2012
 - Wide scale deployment in backbone networks (37%)
 - Wide scale deployment in metro/regional networks (30%)
- ◆ Only 4% believe backbone mass deployment will be later than 2015
- ◆ 25-30% stated that they “don't know/not sure” regarding deployment time frames

100Gb/s Market Realities

- ◆ **Market need exists for 100G**
- ◆ **Market demands are driving carriers and NE vendors to 100G field trials in advance of standards**
- ◆ **Some NE vendors are developing first gen 100G product – may not be as compact as carriers need**
- ◆ **Component/chip suppliers must make significant investments to support 100G in the face of emerging standards, a fragmented customer base and a modest market in the initial years of 100G**

IEEE 802.3ba – ITU-T 100GE/40GE support for OTN

- ◆ IEEE 802.3ba TF - one of the agreed objectives for 40GE/100GE is the appropriate support of OTN
- ◆ ITU-T OTN – Revised Recommendation G.709
 - Mapping 100GE into ODU4/OTU4
 - ODU4/OTU4 bit rate of 111.809973 Gb/s (= $255/227 \times 2.488320$ Gb/s X 40) agreed by ITU-T SG15, Q11
 - Mapping 40 GbE into ODU3
 - Agreement reached to standardize transcoding of 1024B/1027B code method in G.709
 - Mapping of 1GE
 - Agreement reached on Sub-ODU1/ODU0/Time Slot Granularity with a bit rate of 1.244160Gb/s
 - Agreed to add 10X ODU2e(10G3)mapping into ODU4. 10G3 is as per clause 7.1 G.Sup43, +/-100ppm
 - Document in G.Supxx a single option for ODU3y (capable of carrying 4X ODU2e(10G3))

IEEE 802.3ba – ITU-T 100GE/40GE support for OTN

- ◆ The aggregate PCS encoded bit rate for 40GE including 64B/66B coding with MLD lane marker is approximately 41.25Gb/s +/- 100ppm
- ◆ Transcoding is to be used to compress 64B/66B from LAN to a format that fits the OPU3 payload
- ◆ Close cooperation between IEEE and ITU-T to meet the requirements of both groups is maintained

Possible 40GE/100GE Architecture for Support Over OTN

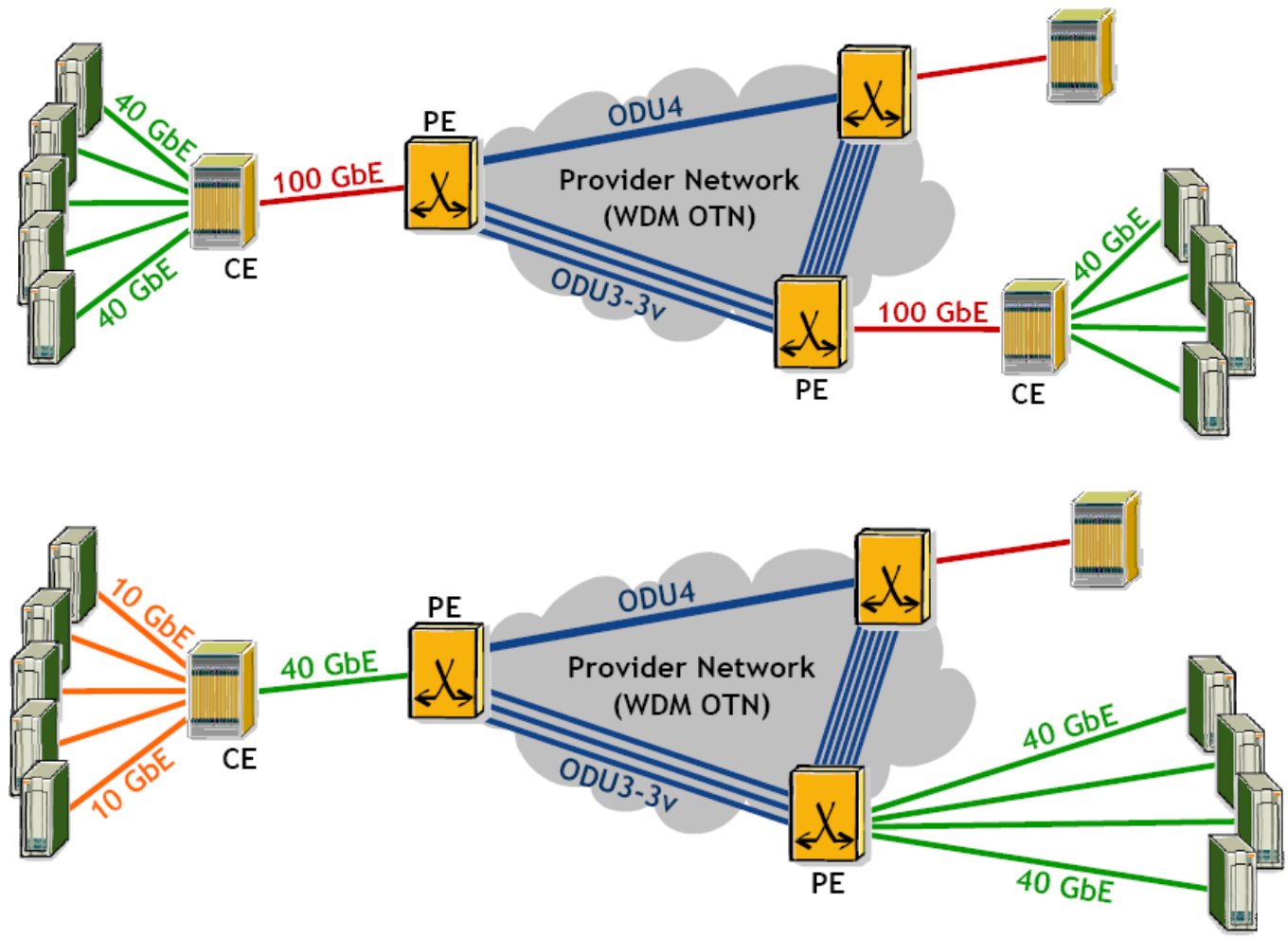

IEEE 802.3ba Activities

- ◆ 40/100Gb Standards Efforts
- ◆ P802.3ba Task Force – 40 GbE and 100 GbE
 - Single task force with objectives to address both rates
- ◆ Support full-duplex operation only
- ◆ Preserve the 802.3 / Ethernet frame format utilizing the 802.3 MAC
- ◆ Preserve minimum and maximum FrameSize of current 802.3 standard
- ◆ Support a BER better than or equal to 10⁻¹² at the MAC/PLS service interface
- ◆ Provide appropriate support for OTN
- ◆ Support a MAC data rate of 40 Gb/s
- ◆ Provide Physical Layer specifications which support 40 Gb/s operation over:
 - at least 10km on SMF - **Approved at Seoul meeting 9/18/2008**
 - at least 100m on OM3 MMF
 - at least 10m over a copper cable assembly
 - at least 1m over a backplane
- ◆ Support a MAC data rate of 100 Gb/s
- ◆ Provide Physical Layer specifications which support 100 Gb/s operation over:
 - at least 40km on SMF
 - at least 10km on SMF
 - at least 100m on OM3 MMF
 - at least 10m over a copper cable assembly

IEEE 802.3ba Interface Architectures Agreement

Aspect	Proposal
40 GbE – Aggregate rate	41.25 Gbit/s assuming 64B/66B
1m backplane	4x10G based on 10G Base-KR
10m copper	4x10G based on 10G Base-KR
100m MMF (OM3)	4x10G, 4 fibers per direction
10km SMF	4x10G CWDM
100 GbE – Aggregate rate	103.125 Gbit/s assuming 64B/66B
10m copper	10x10G based on 10G Base-KR
100m MMF (OM3)	10x10G, 10 fibers per direction
10km SMF	4x25G, 1.3 μ LAN WDM (800 GHz)
40km SMF	4x25G, 1.3 μ LAN WDM (800 GHz)

IEEE 802.3ba Activities continued

- ◆ *Updates from Seoul meeting w/o 9/15/2008*
 - ***Complete review of Draft 0.9***
 - ***Resolution of the 40G \geq 10km SMF objective, with the 4x10G CWDM solution***
 - ***Review of proposed text for 4x10G CWDM proposal***
- ◆ ***With the completion of the above three items***
 - ***Draft 1.0 will be generated with planned member review release date of October 1, 2008.***

Reference Architecture – Clients Networks (IEEE) and Server Networks (ITU-T)

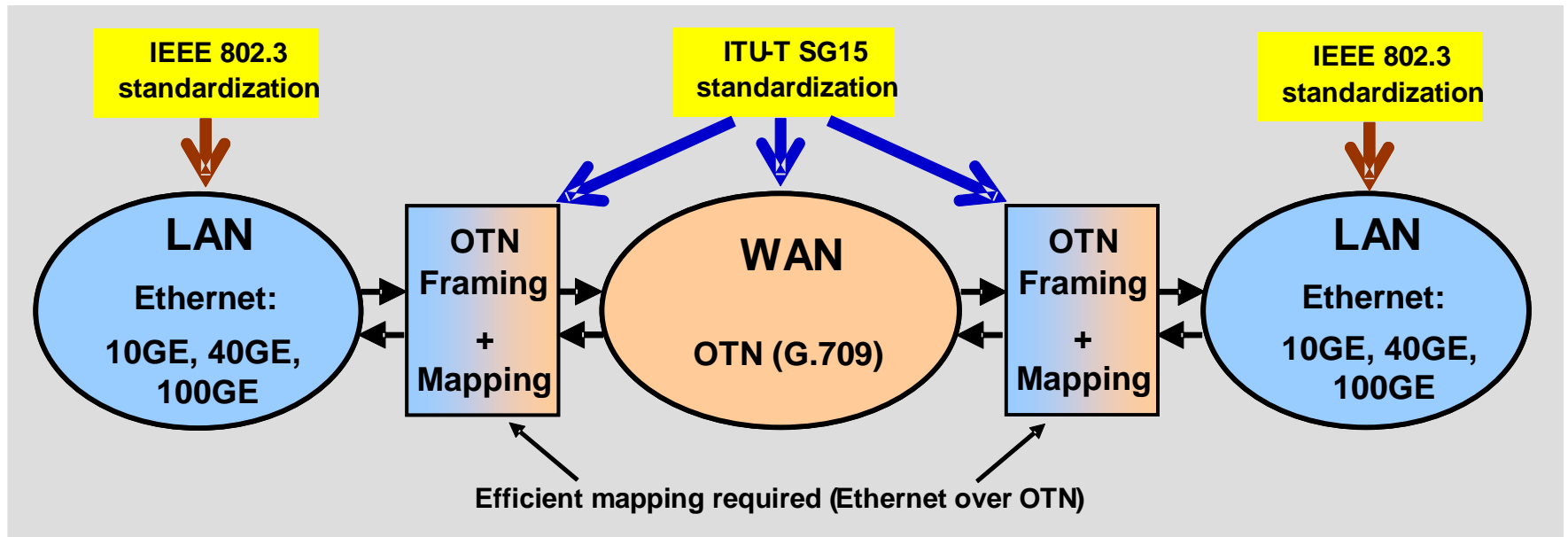

OIF 100Gb/s Activities

- ◆ Carrier Requirements document for 100Gb/s was produced and communicated to the IEEE and ITU-T. The document addresses the requirements for transport services, interfaces and high speed mappings.
- ◆ Project will be coordinated with ITU-T and IEEE standards work.
- ◆ 100G Client & Line Side: Requirements, which drive protocols, architectures, power, electrical, modulation formats, mechanical for line cards, optical transponders, and interface ICs will also be addressed
- ◆ CEI-25
 - A narrow interface for 100-160G SERDES to Framer (SFI), Framer to Network Processor (SPI), TDM-Fabric (TFI) is required to provide dense 100Gbps and 160 Gbps interfaces for future platforms.

OIF 100Gb/s Activities continued

- ◆ **Four new projects initiated:**
 - **100G Long Distance DWDM Transmission Framework**
 - Targets a 1500km application using DP-QPSK modulation format
 - Accelerates development of a specific 100G application having a critical mass of industry support
 - Provides requirements and implementation guidelines on the technology, such as
 - Propagation performance objective
 - Forward Error Correction (FEC) performance target and approach
 - Potential DSP requirements
 - Photonic components implementation agreements for transmitters and receivers

OIF 100Gb/s Activities continued

- **100G Long Distance DWDM Integrated Photonics Components**
 - Develop implementation agreements for transmit and receive photonic components
 - Create a foundation for MSAs for transmit and receive photonic components
- **Forward Error Correction for 100G DP-QPSK Long Distance Communication**
 - Channel Model Definition
 - Encoder Specifications
 - Interleaving Specifications
 - OH (12-14% and 18-20%) Specifications
 - FEC Location in Line Side frame format
- ◆ OIF will continue to work in close coordination with ITU-T and IEEE to help define any associated standards for these and other related projects

OIF 100Gb/s Activities continued

- **Fourth project entitled “Implementation Agreement for a 100G Long Haul DWDM Transmission Module – electromechanical (MSA – 100G LH-EM)”**
- **The implementation Agreement will include**
 - **Definition of the mechanical dimensions of an optical line interface module and its mounting holes**
 - **Definition of the electrical connector**
 - **Maximum power consumption**
 - **Address communication interface**

About OIF

- ◆ Launched in April 1998. It is the only industry group bringing together professionals from the data and optical worlds
- ◆ Open forum: Currently 80+ member companies
 - carriers and network users
 - component and systems vendors
 - testing and software companies
- ◆ Mission: to foster, progress and guide the development and deployment of interoperable products and services for transport networks

Collaboration and Innovation. At Light Speed.

- ◆ **Low-cost Scalable Optical Internetworking**
 - **IP-over-Switched Optical Network Architecture**
 - **Physical layer**
 - Low-cost optical interfaces between networking elements
 - Standard device level electrical interfaces for low-cost systems
 - **Control layer interoperability between data and optical layers**
 - Dynamic configuration using IP signaling and control mechanisms
 - **Network Processing**
 - Hardware interfaces, software APIs
- ◆ **Accommodate legacy network under the new physical and control layer mechanisms**

Output from OIF

- ◆ **Develop Implementation Agreements using**
 - Carrier group's requirements as input
 - Physical Layer User Group requirements as input
 - Existing standards and specification when available and developing new when necessary
- ◆ **Guideline documents, implementation guidelines and software tools**
- ◆ **Develop interoperability testing procedures to ensure interoperability and validate IAs**
- ◆ **Provide input into other standards bodies**

Thank You for Attending!



Contributor: John McDonough – NEC Corporation of America

**For more information on the OIF please visit
www.oiforum.com**