



WORLDWIDE INTEROPERABILITY DEMONSTRATION

SUPERCOMM 2005

About OIF

- ◆ Launched in April of 1998 with an objective to foster development of low-cost and scaleable internet using optical technologies
- ◆ The only industry group bringing together professionals from the data and optical worlds
- ◆ Open forum: 130+ member companies
 - International
 - Carriers
 - Component and systems vendors
 - Testing and software companies
- ◆ Our Mission
To foster the development and deployment of interoperable products and services for data switching and routing using optical networking technologies

OIF Interoperability Tests Architecture

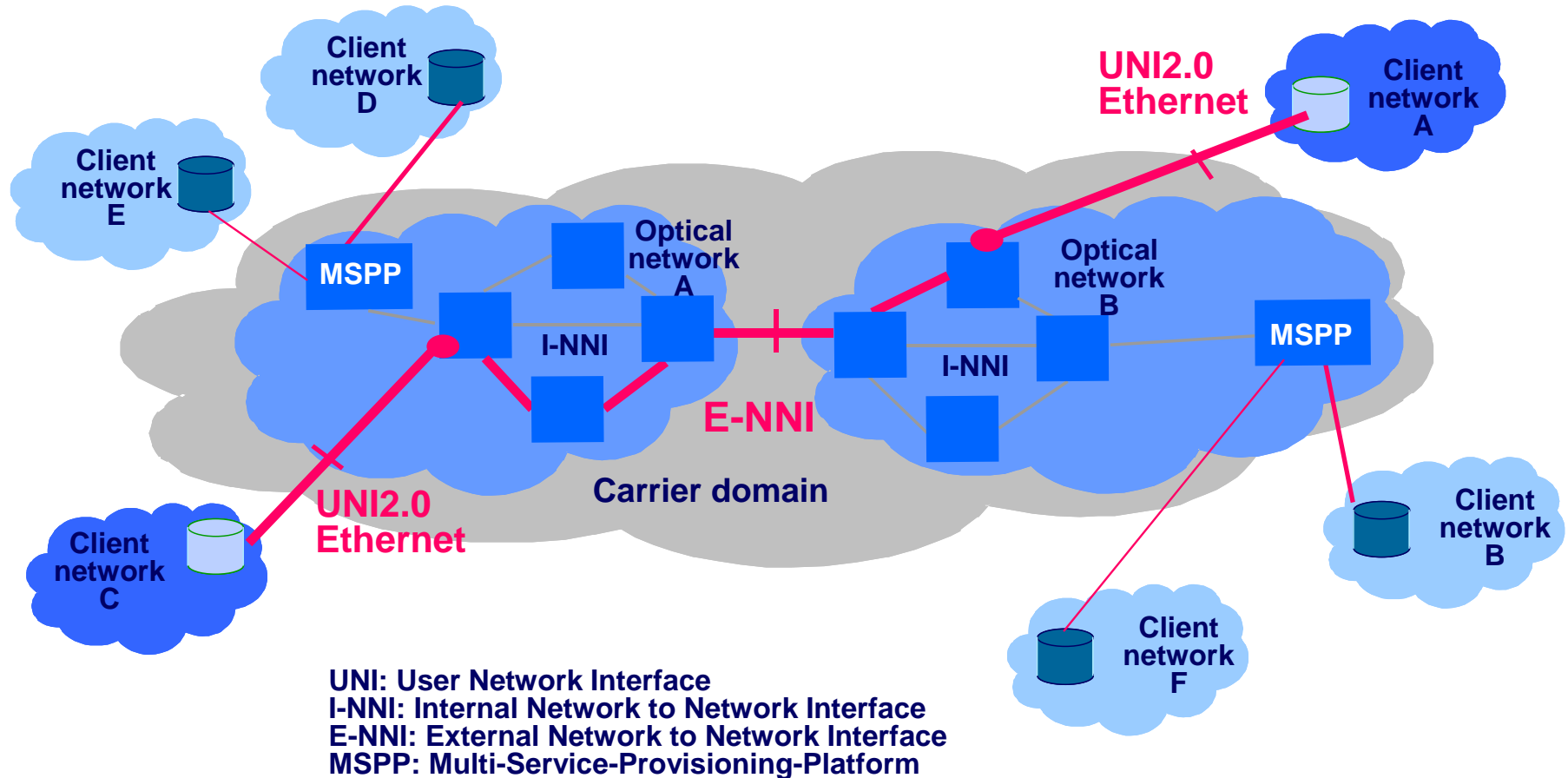

2005 OIF Demonstration: Control Plane Features

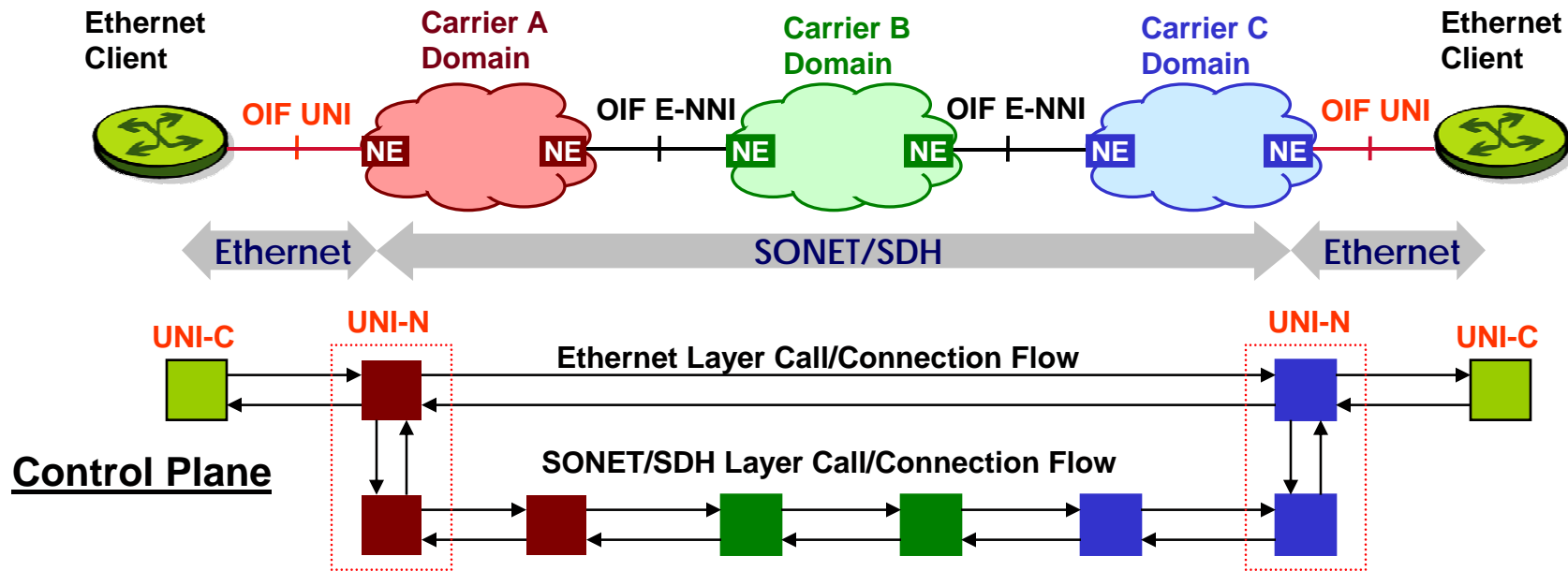

- ◆ Major innovations demonstrated:
 - OIF UNI 2.0 support for Ethernet clients
 - OIF UNI 2.0 call control based on ASON
- ◆ UNI-N devices integrate multi-layer functions of the control plane
 - The clients and the remainder of the carrier network are not impacted, since they are only concerned with one layer

Combining Optical Control Plane with Ethernet Service

Control Plane Interoperability #1

- ◆ Control plane is a key enabler to realize a self-running and self-governing NG-OTN that features multiple technologies and heterogeneous platforms from multiple vendors
- ◆ Within a network domain CP enables:
 - Auto discovery and self inventory
 - Dynamic path provisioning
 - Traffic engineering based on different parameters
 - Combination of protection and restoration schemes
- ◆ Between network domains CP enables:
 - Seamless interworking with client networks (UNI) and other transport network domains (E-NNI) via distributed signaling and routing

Control Plane Interoperability #2

Inter-domain control plane interoperability is enabled by OIF Implementation Agreements:

- ◆ Client network – transport network interface
 - UNI 2.0 Ethernet, enabling clients to request Ethernet transport services by direct signaling to the corresponding transport network edge node
- ◆ Between transport network domains:
 - SONET/SDH based E-NNI 1.0, enabling automatic connection configuration over multiple, independent network domains

2005 OIF Demonstration: Data Plane Features

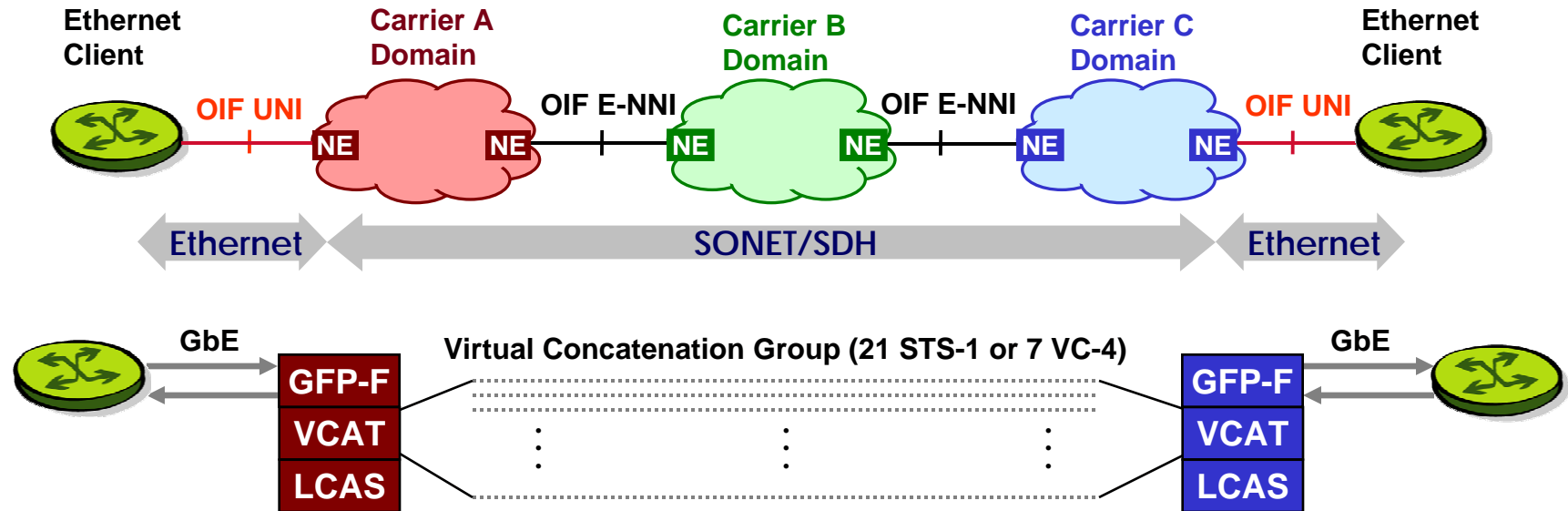

- ◆ Major innovations demonstrated:
 - Ethernet over SONET/SDH adaptation using GFP/VCAT/LCAS
 - Creation and deletion of VCGs triggered by UNI connection requests
- ◆ The edge devices integrate multi-layer functions of the data plane
 - The clients and the remainder of the carrier network are not impacted, since they are only concerned with one layer

ITU-T and OIF Collaboration

OIF

- ◆ Carrier requirements
- ◆ Interoperability testing
- ◆ Protocol specifications in UNI Implementation Agreement
- ◆ Adoption of ITU-T Recs.

ITU-T

- ◆ ASON Recommendations for optical signaling and routing
- ◆ Transport Recommendations for GFP/G.7041, LCAS/G.4042, VCat/G.707, Ethernet

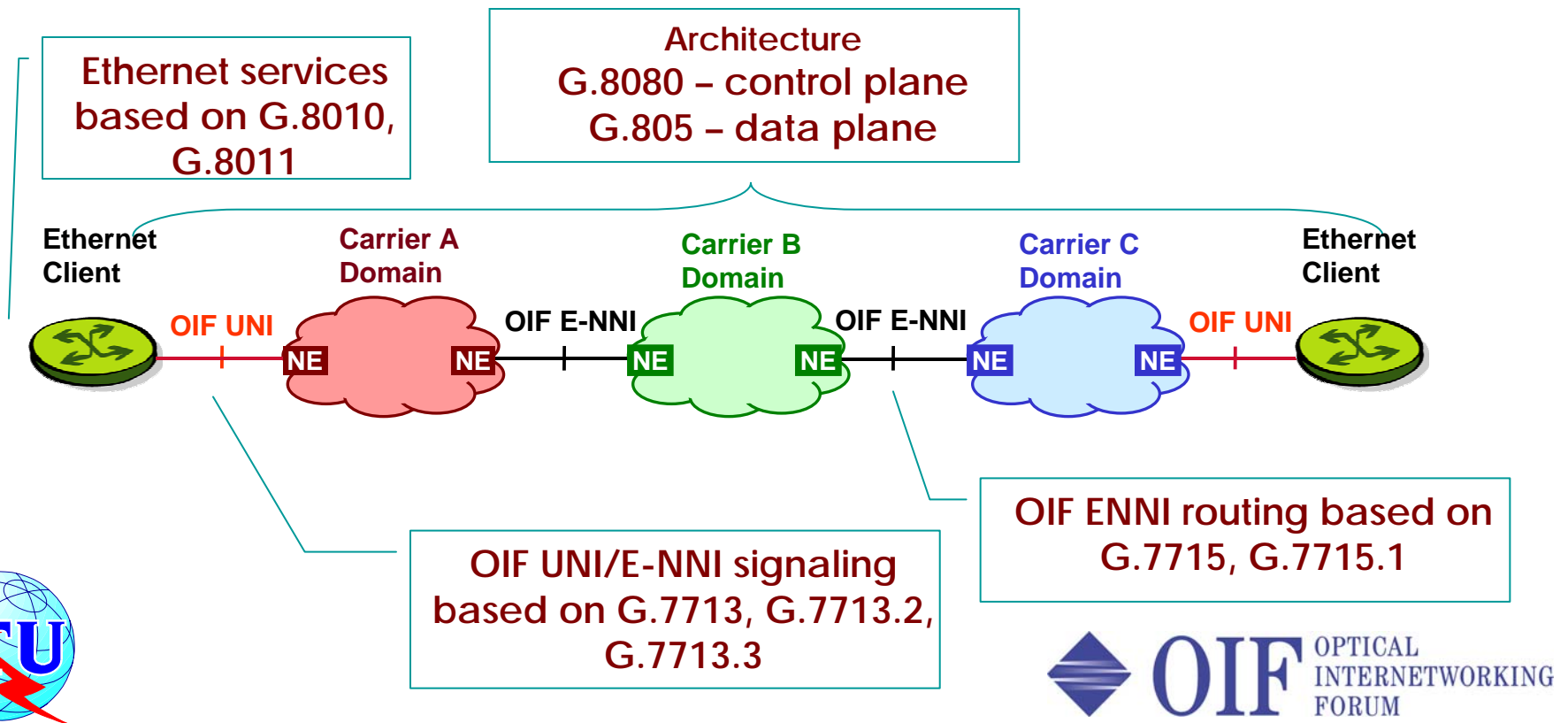

Global Topology

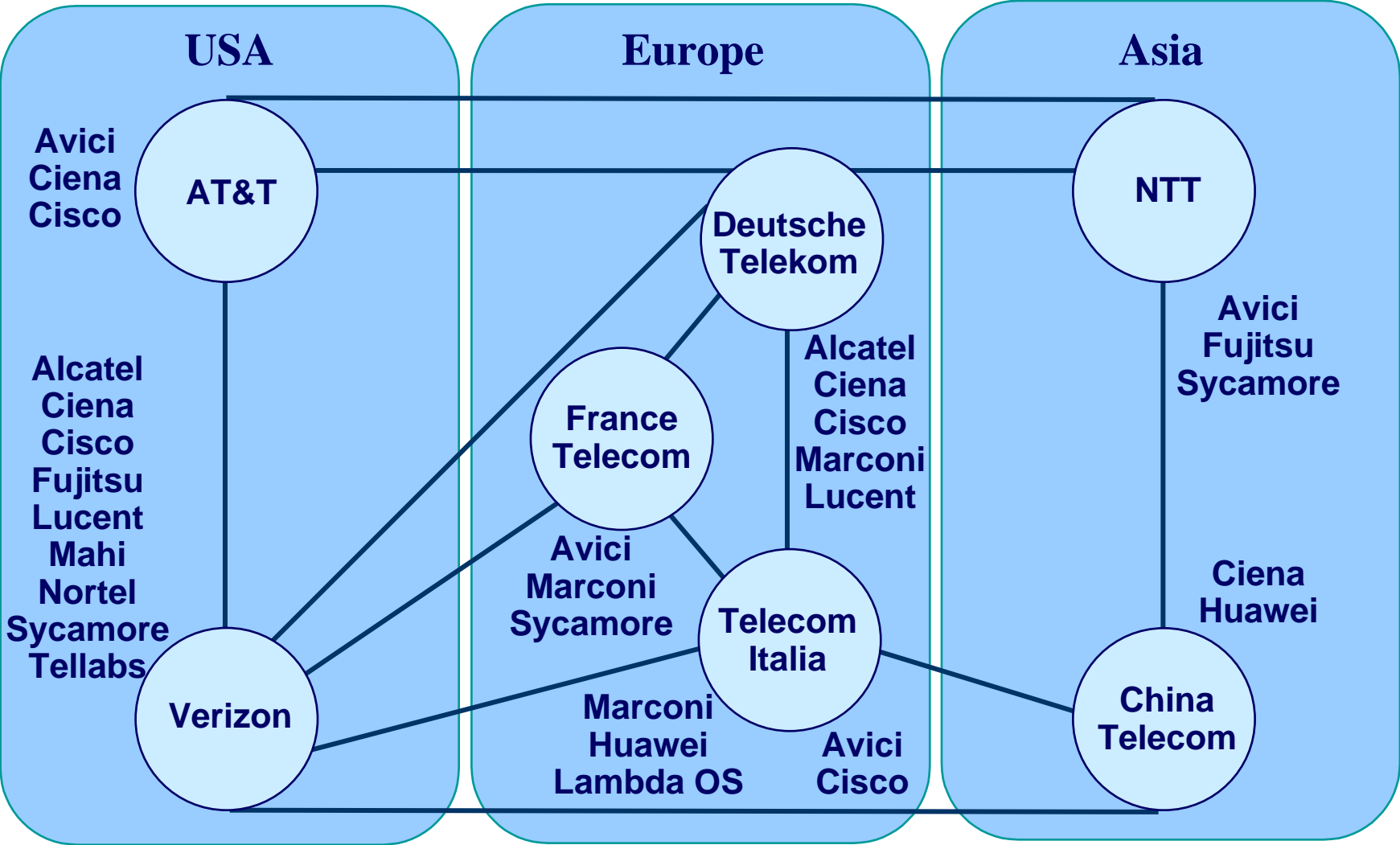

Opportunities enabled by Interoperability for Network Users

Fast, flexible and network users directed provisioning of data services over control plane enabled SONET/SDH networks

- ◆ Fast data service provisioning on national and global scale
- ◆ Bandwidth optimization
 - Map Ethernet efficiently to SONET/SDH payload → cost efficient
 - Dynamic SONET/SDH bandwidth allocation according to Ethernet usage → cost efficient
 - In-Service bandwidth adjustment at any time → network users directed
- ◆ Global coverage of data services, based on SONET/SDH networks
- ◆ Provides high reliability based on multiple resilience mechanisms

Opportunities enabled by Interoperability for **System Vendors**

- ◆ Vendors are committed to prove that their implementation are compliant with standards and interoperable
- ◆ Vendors foster deployment of new data services by providing interoperable solutions
- ◆ Interoperability of vendor network domains is a precondition for global coverage of network services
- ◆ Interoperability eases system integration of different vendor solutions and therefore opens market opportunities for Ethernet, SONET/SDH and other equipment

Opportunities enabled by Interoperability for Carriers

- ◆ Carriers can provision end-to-end dynamic connections for flexible data services over multiple, control plane enabled SDH/SONET domains
- ◆ Carriers can deploy at faster pace innovative network technologies
- ◆ Carriers are enabled to select cost effective and leading edge network elements, platforms and multi-vendor solutions
- ◆ Carriers are enabled to reduce operations overheads and simplify provisioning of new services

Video Streaming Application between AT&T and Verizon Labs

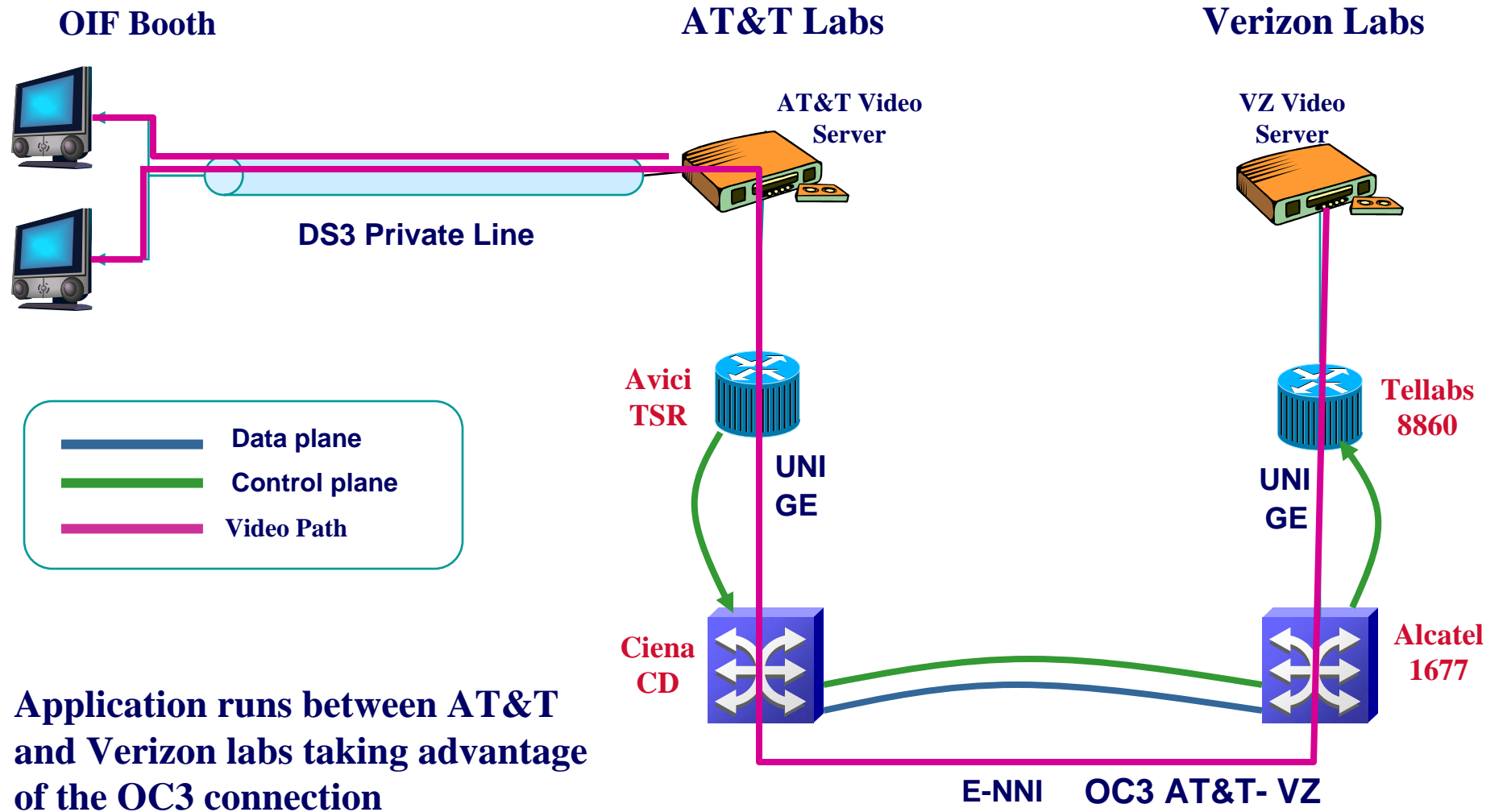

Significance of the Event

- ◆ Industry's first - On-demand Ethernet service using an optical control plane
- ◆ Control plane connectivity built out around the world lays the foundation for future testing methodology and infrastructure
- ◆ Successful control plane and data plane integration validates OIF's Implementation Agreements
- ◆ Participation of 13 industry leading vendors and 7 major carriers signifies the wide technology adoption in industry

Thank you for attending!

For more information on the
OIF
please visit
www.oiforum.com

