



AT THE



WORLDWIDE INTEROPERABILITY DEMONSTRATION
SUPERCOMM 2005

OIF UNI and E-NNI and the Unified Control Plane

Control Plane Initiatives

- ◆ Unified control plane (UCP) initiatives propose to automate service planning and delivery tasks in order to lower OpEx and increase service potential
- ◆ Several UCP standards efforts and implementation models exist
 - **ITU-T ASON**
 - Propose control plane communications framework
 - **IETF GMPLS**
 - Define control plane discovery, routing, & signaling protocols
 - **OIF UNI/E-NNI**
 - Define protocol extensions to ensure multi-vendor interop
 - Provide forum for service providers and vendor s communities Forge working partnership

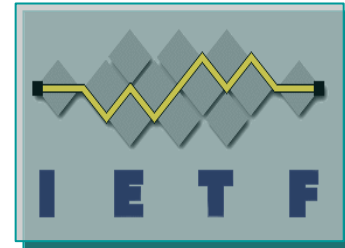

The OIF UNI/E-NNI Advantage

- ◆ Present mode of operation
 - Labor-intensive, lengthy and expensive provisioning cycle
 - Requires long service contract to achieve profitability targets
- ◆ PMO limitations negatively impact new data services
 - Service cost and delivery delays

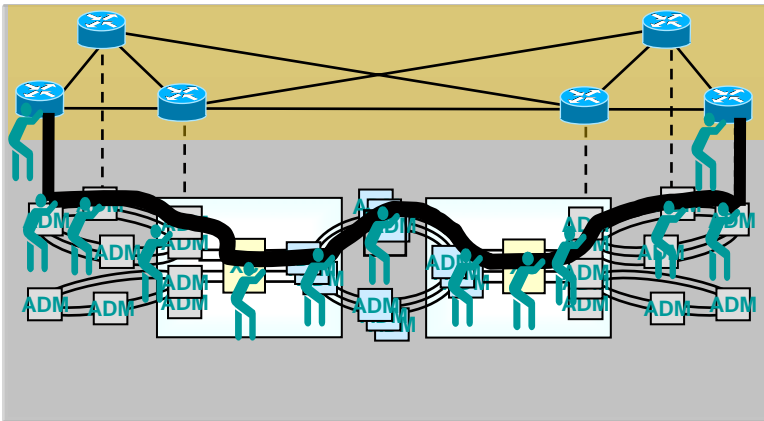

- ◆ Offers flexible, rapid, low cost service delivery options
 - Rapid provisioning
 - Remote configuration
 - Multi-vendor interoperability
- ◆ Underpins new data services and supports business goals
 - Improved customer satisfaction

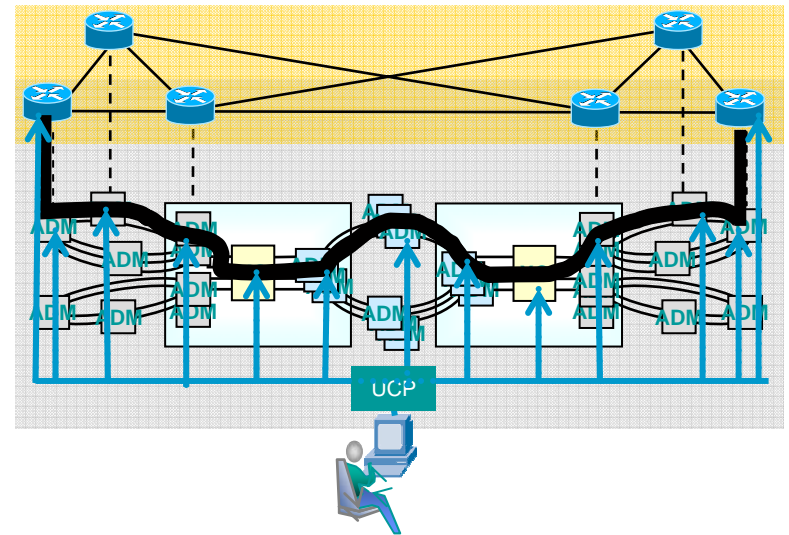

Key OIF Control Plane Developments

- ◆ **Optical User to Network Interface (O-UNI)**
 - Utilized between client network and optical network
 - Signalled and SPC connection creation, deletion, query
 - No topology info exchanged between client and network
- ◆ **External Network Node Interface (E-NNI)**
 - Utilized between optical networks, and between areas within a single network
 - Signalled connection establishment, removal, restoration
 - Summarized topology/reachability info across domains
- ◆ **Security Management Interfaces to Network Elements**
- ◆ **Security Extension for UNI / NNI**
- ◆ **Call Detail Records**

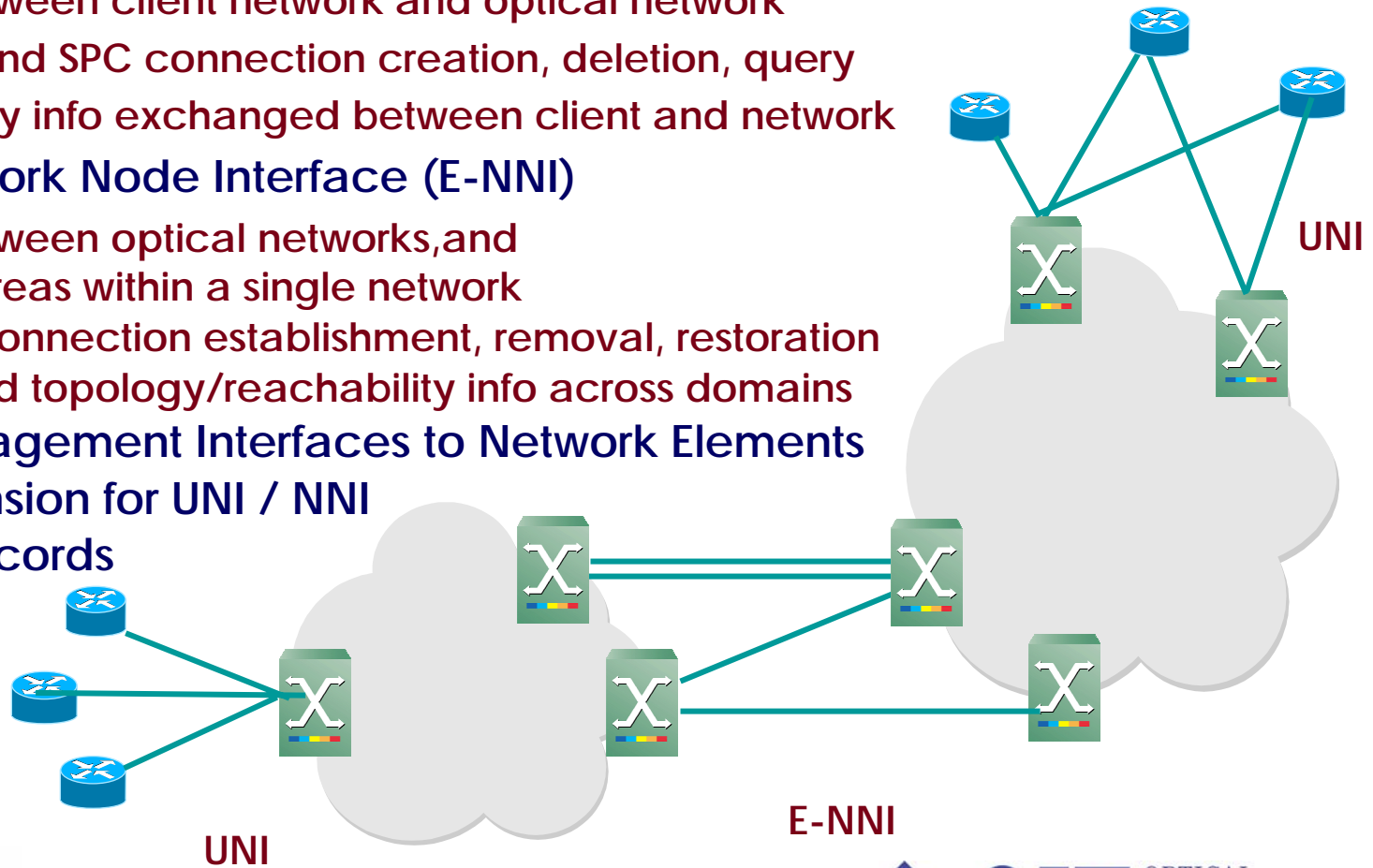

OIF Communications Model and Protocols

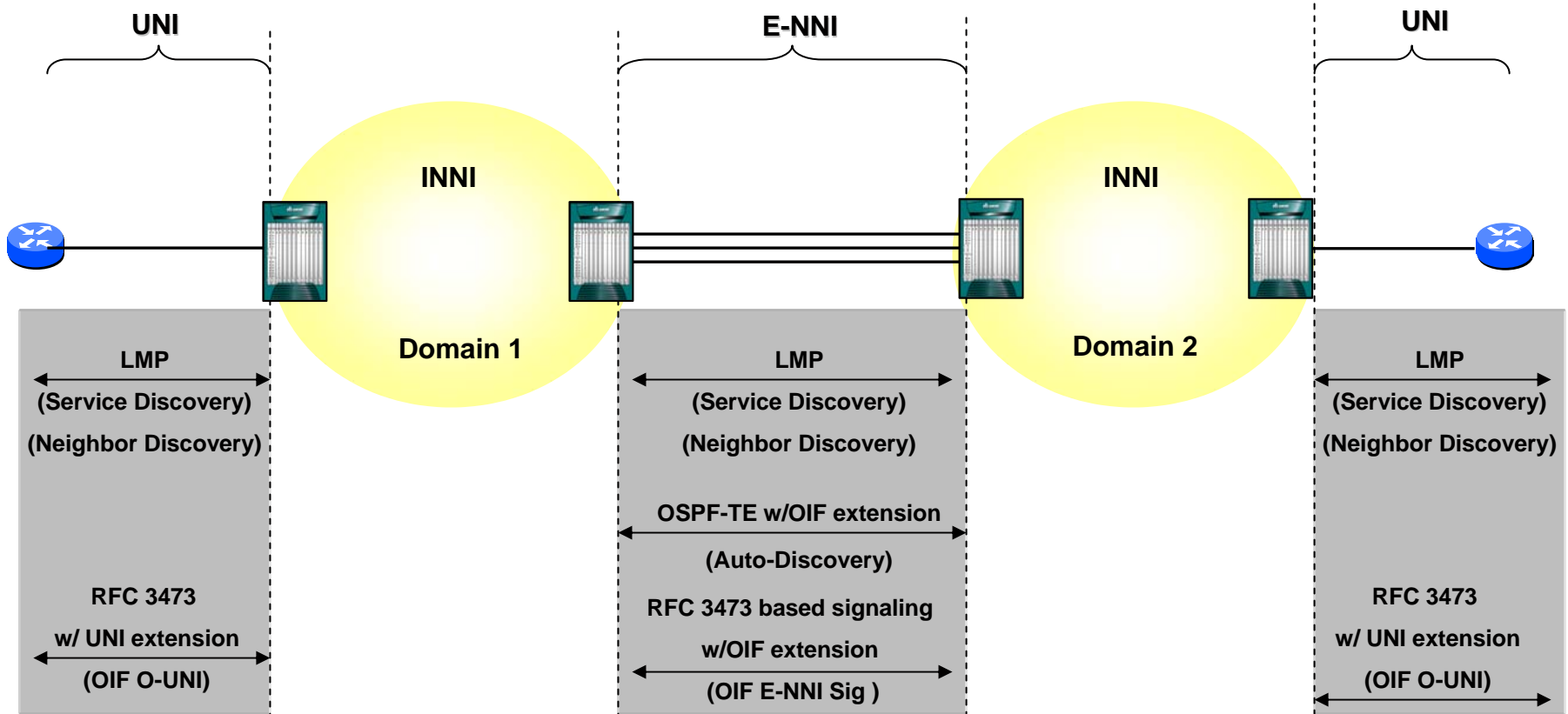

2nd OIF Worldwide Interoperability Demo

- ◆ Participants
 - 7 Carriers
 - 12 vendors
- ◆ Testing conducted in carrier labs, under carrier supervision
- ◆ Test Cases
 - UNI 2.0*
 - E-NNI
 - E-LINE
 - E-LAN*
- ◆ Demo managed from OIF Booth, networked to carrier labs
 - Live connection visualization
- ◆ Other recent OIF-based events
 - iPOP '05
 - VIOLA Test Bed
 - GDTC ASON eval



**New features for 2005*

UNI 2.0 Features

- ◆ Ethernet client support
 - Extends O-UNI to Ethernet attached client networks
- ◆ *Multi-homing**
 - Diverse routing of UNI 2.0 client links
- ◆ *G.709 services**
 - ITU-T OTN services
- ◆ *SAN services**
 - Storage Area Network support
- ◆ *Diversity**
 - Signaled connection requests for diverse link, node, and SRLG paths

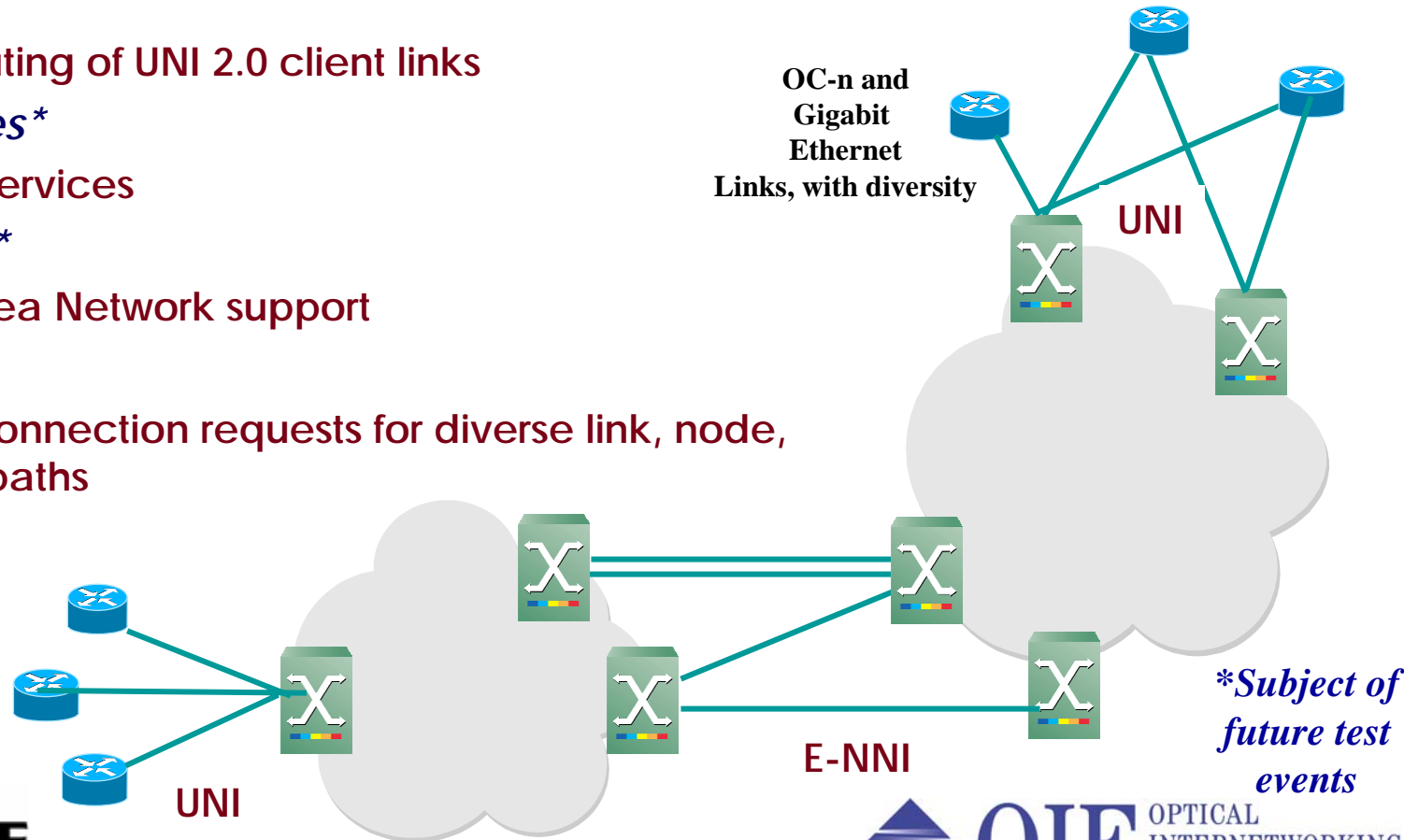

Ethernet Services Features

◆ E-Line Service

- Support pt-to-pt Ethernet circuits, enables TDM-like private line service
- Testing included
 - Generic Framing Protocol (GFP, ITU-T G.7041)
 - Virtual Concatenation (VCat, ITU-T G.707)
 - Link Capacity Adjustment Scheme (LCAS, ITU-T G.7042)

◆ ELAN Services

- Support pt-pt *and* mpt connections based on Layer 2 info, enabling
 - Virtual Private Line
 - Virtual Private LAN
 - Internet Access Apps
- Testing included:
 - GFP, VCat, LCAS
 - Packet forward based on VLAN tag

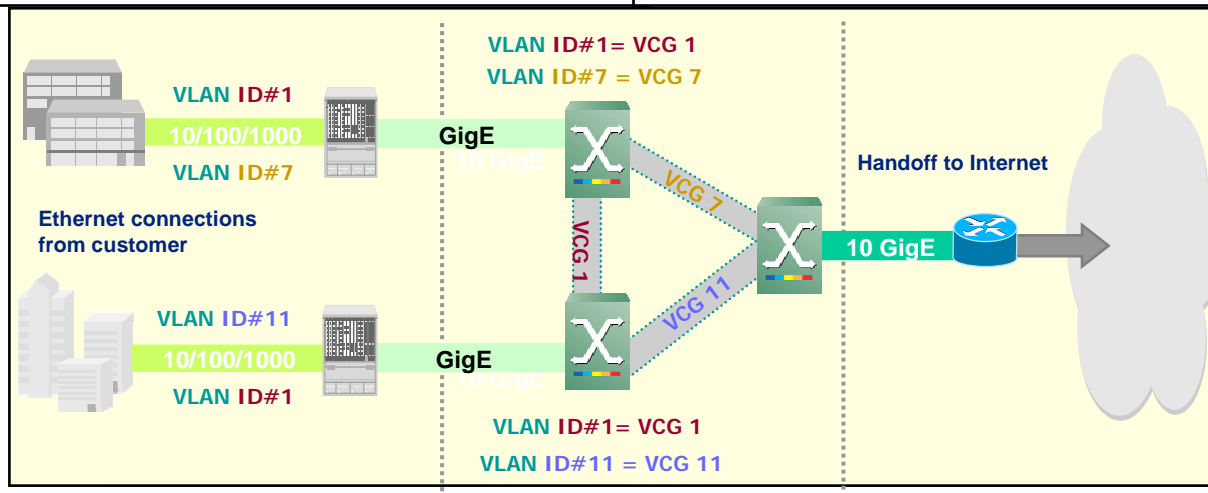

Next Steps and Summary

- ◆ Traditional network ops limit the ability to offer new data-centric applications and services in a cost and resource efficient manner
 - Time and labor-intensive inventory and provisioning processes
 - Limited service levels, protection schemes, service differentiation
- ◆ OIF UNI/E-NNI enables the efficient deployment of these new services
 - Rapid, flexible provisioning
 - Multi-vendor interoperability
- ◆ Keys to ongoing success
 - Joint carrier / vendor participation
 - Liaison between standards organizations

