



100G Ultra Long Haul DWDM Framework Document

Executive Summary

The objective of this document is to describe the OIF work on 100G DWDM transmission. The objective of this work is to aid the industry in the development of transceiver technology for transport of 100G signals in long distance backbone networks. This document identifies high level system objectives for this network application, and focuses on one specific implementation approach for a transceiver module. It describes the modulation method chosen for this implementation, and the rationale for this choice. It identifies a transceiver module functional architecture, and decomposes that architecture into a number of technology building blocks. It describes related OIF 100G projects that provide detailed specifications for these building blocks. Creating common technologies can provide a basis for interoperability, but this project does not include full interoperability of system level implementations within its scope.

Project Overview

Motivation

The purpose of this project is to accelerate the availability of 100G transmission technology for ultra long haul DWDM networks. While many research publications have demonstrated 100G DWDM transmission technical feasibility, prototype 100G transceivers have been developed, and field trials of 100G transmission solutions have been conducted, it will take substantial investment at the component, subsystem and system level before there is widespread availability of technologies that will allow the creation of system solutions that meet both the performance and economic objectives described above. This project aims to develop a consensus among a critical mass of module and system vendors on the requirements for specific 100G technology elements so as to create a larger market for these components. Such a consensus will improve the business case for the required base technology investments.

Project Scope

This project targets specifications for DWDM transceiver implementations for application to data switch and router line interface modules, optical switch line interface

modules, DWDM system transceiver modules, and DWDM system multiplexer-transceiver modules.

Excluded items

This project excludes any other aspects of data switches and routers and optical switches. It excludes client interface modules for 100 GbE or 100G OTN. It excludes other elements of DWDM transceiver line systems, such as optical multiplexers, demultiplexers, amplifiers and ROADMs

Network Application Target and Objectives

This project addresses the long distance transmission application in high capacity core optical networks. These networks can be of continental scale, and have current maximum link capacities in the vicinity of 1Tbit/sec, consisting of roughly 80-100 optical channels at 10 Gb/s data rates. While data rates of 10 Gb/s make up the majority of channels, deployment of 40Gb/s optical channels has begun. These networks are operated by large commercial service providers and by government agencies. While primarily targeting 1000 km – 1500 km ULH performance with up to 6 ROADMs, other potential applications should be kept in mind as well, including ULH applications with larger numbers of ROADMs as well as Metro applications with more than 20 ROADMs, in an attempt to maximize commonality with a broader range of 100G applications.

Commercial network operators cite a long term trend of traffic growth at rates of 50% per year or higher. Given their current network traffic load and growth rates, carriers have expressed an urgent need to increase the capacity of their core networks. They wish to accomplish this by increasing optical channel rates to 100 Gb/s. They have also stated an objective to raise total capacity of their transmission systems by a factor of 10 when upgrading from 10 Gb/s channels to 100 Gb/s channels. This requirement implies that optical channel spacing, today typically 50 GHz, be maintained. An additional requirement is that these upgrades be possible with currently deployed systems, without requiring additional fibers or new common equipment, such as optical line amplifiers. While not true in every deployment, we presume line systems which are partially compensated for chromatic dispersion. A further objective is that it be possible to maintain the maximum regeneration spacing of their current networks, which is in the range of 1000 to 1500 km. Over this distance it is common to have up to 6 ROADMs. Metro and regional networks would have shorter maximum propagation requirements but could have a greater number of ROADMs. 100 Gb/s channels intrinsically require 10x higher optical signal to noise ratio (OSNR) than comparable 10 Gb/s channels. This puts a very stringent requirement on tolerance to amplified spontaneous emission (ASE) noise from existing optical amplifiers. Network operators have also expressed a general financial threshold for 100G transmission channels, primarily that overall cost/bit/sec/km see improvement over 10G channels. They have also expressed a desire to see improvements in power dissipation/bit/sec and equipment density.

While we realize that achieving adequate propagation distance is one of the most important objectives for 100G in the network core, this project will not seek to predict absolute propagation performance. It will leave that task to system vendors, and rely on

them to provide feedback to carriers. The requirement to maintain 50GHz optical channel spacing will drive the choice of a more spectrally efficient modulation format than the on-off keying used commonly at 10G today. The requirement for higher noise tolerance motivates the choice of a more noise tolerant modulation format and a more noise tolerant receiver design. An additional tool to improve noise tolerance is forward error correction (FEC.) The industry has learned from its 40G developments that while chromatic and polarization mode dispersion can be mitigated by optical techniques, the solutions can be costly and consume considerable space.

Transceiver architecture

Modulation

In this section we describe the choice we have made in modulation format and some of the rationale behind this choice.

The OIF has begun its 100G efforts by studying coherent DP-QPSK. Other modulation formats may meet or exceed the desired LH propagation objective of 100G transport over channels designed for 10G 50GHz transport. These may be addressed in a further phase of the project. The OIF's coherent DP-QPSK studies have been useful to drive considerations and requirements for the subcomponents. Where practical, subcomponents are specified to be reasonably modulation independent.

This project has adopted dual polarization quadrature phase shift keying (DP QPSK) modulation with a coherent receiver. Modulation formats other than DP-QPSK are not discussed in this white paper. Dual polarization refers to the combination of two independent optical signals of exactly the same frequency, but with orthogonal polarizations, as illustrated in Figure 1. These two optical signals are obtained from a single transmit laser, and each signal is independently modulated to carry half of the data payload. The actual transmitted signal bit rate is the sum of the payload data rate plus additional overhead for data encoding, transmission management and forward error correction (FEC). While this rate is not yet specified, it will be somewhat above 110 Gbit/s

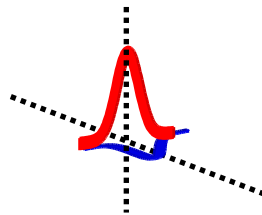

Figure1. Dual Polarization

Dividing the data among two optical polarizations allows each polarization to operate at half the data rate that would be required for a single polarization. Cutting the modulation rate in half reduces the optical bandwidth required to carry the signal, allowing more tightly spaced channels. This contributes to our objective of maintaining a 50 GHz channel spacing for 100G channels.

In addition to choosing dual polarization transmission, this project also selected phase shift keying modulation. Rather than signaling by turning light on and off (on-off keying modulation), phase shift keying relies on changes to the phase of the optical carrier to encode data. There are many varieties of phase shift keying available. This project selected quadrature phase shift keying, which employs four transmission symbols, each represented as a red spot in the signal phase diagram shown below in Figure 2. Figure 3 illustrates how a transmitted signal's phase is shifted to reflect the data that is encoded. This figure shows that the data signal is the combination of a modulated in-phase signal and a quadrature signal. These two signals are modulated in parallel and then combined.

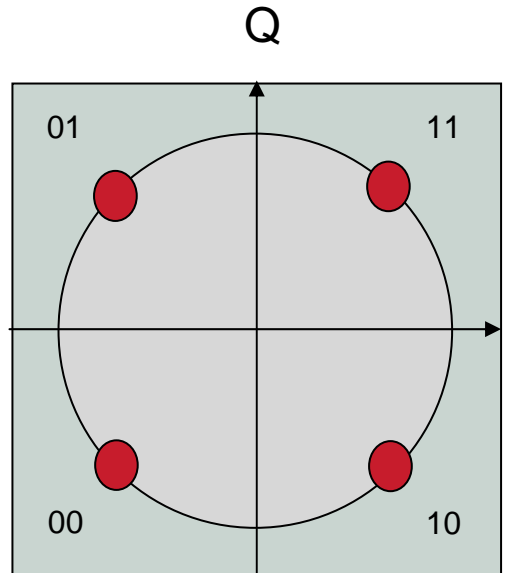

Figure 2. Representation of the association between signal phases and two bit data sequences.

In comparison with on-off keying modulation, QPSK modulation allows a reduction of transmitted symbol rate by a factor of two, which narrows the signal spectrum and reduces the speed required of optical and electronic components. The combination of dual polarization and QPSK reduces the required symbol rate by a factor of 4, allowing the application of lower cost technologies. At the same time a lower symbol rate reduces the sensitivity of the signal to a number of optical propagation impairments.

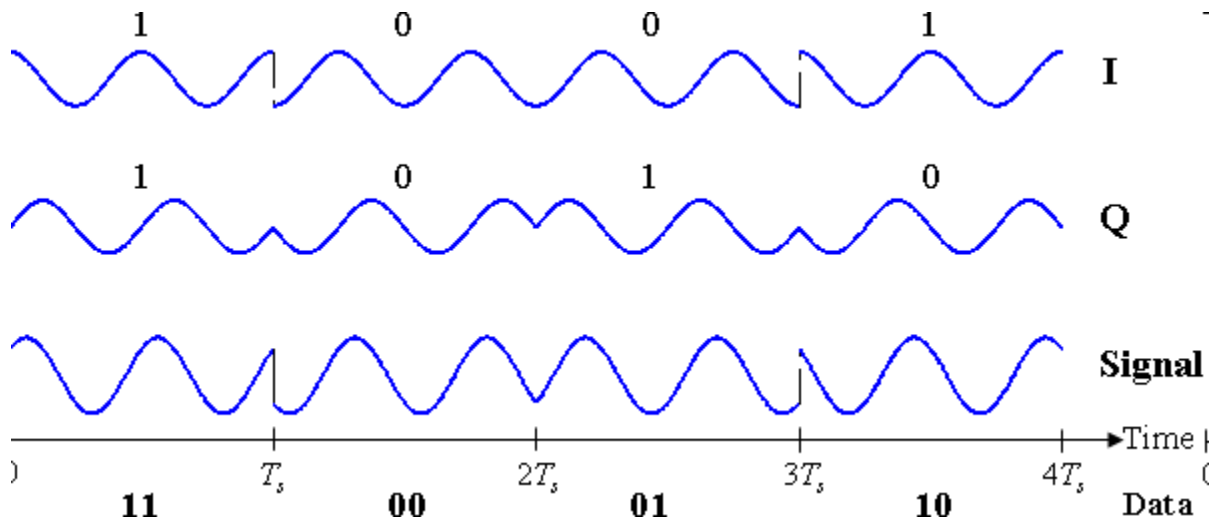

Figure 3. Independent modulation in-phase and quadrature signals which are added together to form a transmitted signal with QPSK modulation

This project also specifies a coherent receiver. A coherent receiver operates in a way similar to a radio receiver, where a strong local oscillator at a frequency near the received signal is mixed with the received signal, generating mixing products at the difference frequency. Optical signals are extremely high in frequency, but the difference between the received optical signal and the local oscillator is chosen such that the resultant product is down converted and can be detected electronically. One advantage of a coherent receiver is an improved signal to noise ratio. Another advantage lies in its ability to compensate for several types of propagation impairments. A coherent receiver preserves the phase information of the optical signal. With available phase information an electronic equalizer can be used to recover both polarizations and to compensate for a number of signal impairments, including chromatic dispersion and polarization mode dispersion, caused by long distance propagation. The received analog signal components are digitized in high speed analog to digital converters (A/D), then passed on to a digital signal processing (DSP) ASIC. While coherent optical receivers were the subject of much research almost 20 years ago, the current availability of high speed A/D converters and the technical feasibility of creating high speed, highly complex DSPs in state of the art CMOS integrated circuit technology makes them now practical. The application of digital signal processing to coherent optical receivers has been the subject of intense research for the last several years.

Integrated photonics

In making a change from on-off keying modulation to DP QPSK modulation we have reduced the symbol rate by a factor of four but increased the number of signal components by the same factor of four. The complexity of the photonic components of a DP QPSK transmission module is shown in Figure 4. A transmission laser generates a light signal that is split into four components, two for the horizontal polarization and two for the vertical polarization. The polarization shifter rotates one of the signals relative to the other, after which they are combined to create an output signal. Within each polarization there are in-phase and quadrature signal components. Each signal component

requires a modulator to encode data. Four drivers convert low level logic signals to signal levels required by the modulators.

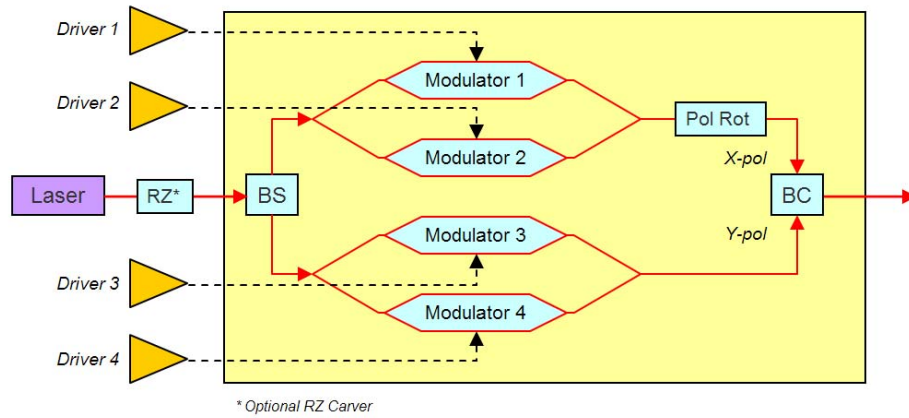

Figure 4. Block diagram of a DP QPSK transmitter module

The transmission module offers a number of opportunities for cost and size reduction by component integration. Modulators are candidates for integration, as are drivers. The OIF has created an integrated photonics project to specify an Implementation Agreement for an integrated transmitter module, which will determine the appropriate modularity.

In Figure 5 we show a schematic diagram of a DP QPSK receiver module. This consists of a number of passive optical components that form a demodulator, followed by optical detectors and transimpedance amplifiers. Again, there are opportunities to apply integration technologies to reduce cost and size of a transceiver. The functionality shown in the figure below will be implemented in an integrated receiver module. Just as for the transmitter module, the OIF will create an Implementation Agreement specifying the integrated receiver module.

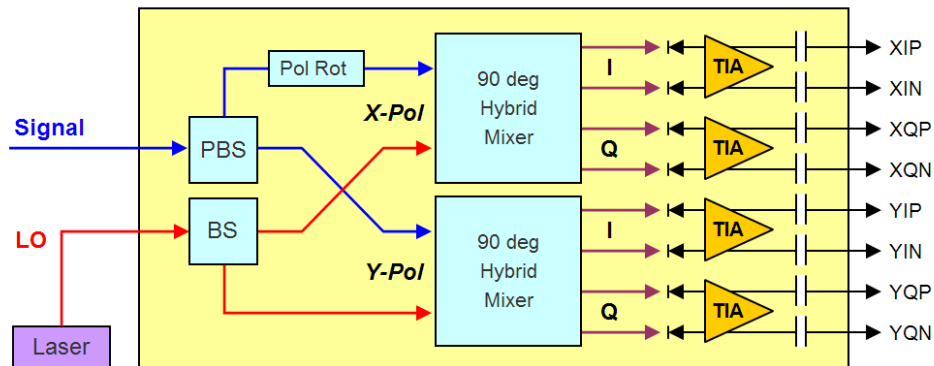

Figure 5. Block diagram of a DP QPSK receiver module, shown with balanced detection and outputs.

Forward error correction

The need for a 10X greater OSNR in 100G than in comparable 10G links will need to be addressed by a combination of methods, including forward error correction techniques. Current 10G links use FECs with gains in the range of 8.5dB. The introduction of higher FEC gains at 100G will help to close the SNR gap. However, as shown in Figure 6, Shannon's limit prevents FEC from closing the gap entirely. Instead, FEC designs can only attempt to approach the Shannon limit asymptotically, to the degree that can practically be achieved.

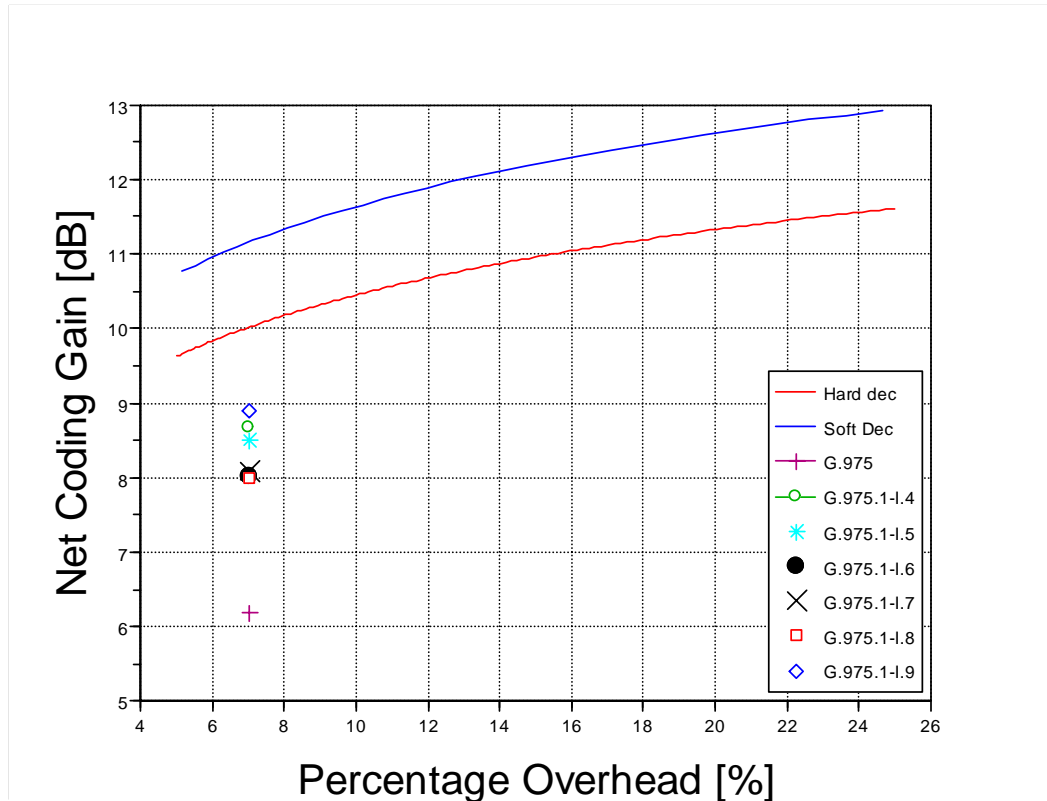

Figure 6. Theoretical limits and experimental results for performance achieved with several forward error correction codes.

In Figure 6 we show a number of results on FEC coding gain as a function of overhead rate. The continuous lines are the Shannon limits for both hard decision decoding and soft decision decoding. In hard decision decoding a single signal level is chosen as a discriminator between a “1” and a “0.” Soft decision coding divides the signal level space into finer divisions, and uses this richer set of information to make a decision on whether the symbol is a “1” or a “0.” Discrete data points in the figure show results achieved on specific codes. The RS(255,239) code is the default code standardized in G.709, and has a net coding gain of approximately 6dB. The FEC standardized for the OTN is documented in G.975. The figure includes results for several hard decision enhanced FEC codes (EFEC codes) that are in common commercial use for 10G systems today. In this

figure we have chosen several that are documented in G.975.1. At the same overhead rate as the G.709 code several yield an improvement in net coding gain of more than 2dB.

Soft decision FEC is seen to offer the potential of higher net coding gain than hard decision FEC, but this brings along with it the need for a much higher data transfer requirement between the digital signal processor device and the FEC decoder. For example, if we increased signal resolution from two divisions, to separate a “0” from “1,” to four divisions, it would double the data rate, as two bits would be required to encode the four possibilities. A higher FEC overhead rate would further increase the data transfer rate required. Stronger FEC codes are expected to be implemented in the optics module.

An improvement in net coding gain of 3dB results in an increase in the unregenerated optical propagation distance of a factor of two. Work is needed to explore potential performance gains that might be achieved by new codes and by dedicating slightly higher overhead for FEC. We will have to assess tradeoffs between the benefits of increased overhead rates and propagation penalties that come with higher symbol speed. We will also need to assess the impact of higher speed on ASIC performance, and the impact of higher complexity codes on the implementation complexity of electronics technology. These detailed considerations will take place in the context of a related OIF project, “Forward Error Correction for 100G DP-QPSK LH Communication.”

Transceiver Module - Electro mechanicals

Another related OIF 100G ULH DWDM project will specify the mechanical aspects of a transceiver module. Specifications will include a maximum physical size, provisions for module mounting, and maximum power dissipation. It will specify an electrical interface, connector, and control protocol. Unlike the other 100G projects discussed above, this 100G module project is not limited to DP QPSK modulation, although it is intended to support that modulation format.

Transceiver building blocks

Figure 7 shows how the major functional blocks of a DP-QPSK transceiver module discussed above come together. All the blocks illustrated are contained on a single printed circuit board. The large block on the right represents the 100G transceiver module – electro mechanicals. As discussed above this OIF project addresses physical aspects of this module and the electrical data and control interfaces to it. For the DP-QPSK implementation that is the subject of this project the module includes lasers, integrated photonics modules, QPSK encoders, A/D converters and the digital signal processor. It may optionally include FEC in the case where it is advantageous to tightly integrate the FEC with the digital signal processor, as in the case of soft decision FEC. The functional blocks on the right include OTN framers and FEC that reside outside of the transceiver module. The red dots in Figure 7 identify interfaces that will be specified in related implementation agreements.

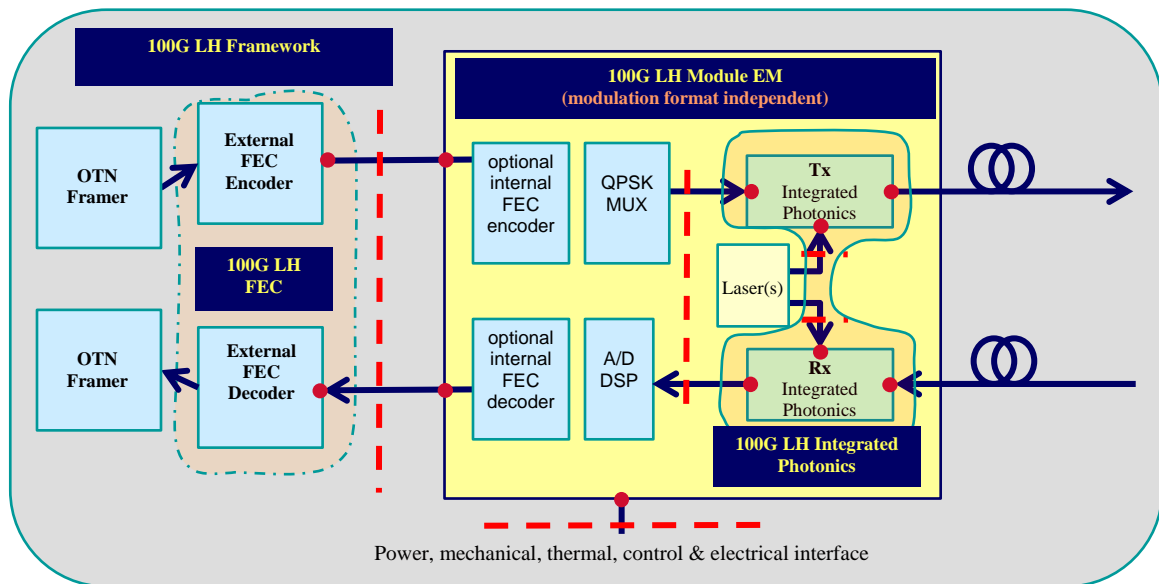

Figure 7. Block diagram of a transceiver module

Starting with the transmit direction, incoming data is first framed according to OTN specifications before the application of FEC. The signal then passes to the transceiver module. Data is converted to drive signals to control the optical modulators. A transmit laser provides the light source for the modulators. On the receive side the incoming signal is mixed with a local oscillator, demodulated into components, detected, amplified, digitized, then passed into the DSP module. A digital bit stream is then passed to a FEC decoder, which may exist either inside or outside the module. The final step is OTN framing.

Relationship to standards activities

This project will require as input standards under development by the IEEE and ITU-T. The major stimulus of this project has been the work in the IEEE to develop 100 Gigabit Ethernet. The 100 GbE signal is expected to be an extremely important client signal for transport across core optical networks. The ITU-T is working closely with the IEEE to create a new standard transmission rate and signal format to support managed efficient transport of the 100 GbE signal. In the following we consider the relationships of this project to these external activities.

IEEE P802.3ba – 40 Gb/s and 100Gb/s Ethernet Task Force

One of the objectives of the IEEE P802.3ba Task Force is to standardize 100 Gigabit Ethernet. While the objective of this OIF project is to support wide area transmission of the 100 GbE signal, it is not anticipated that this project will have any impact on the IEEE 100 Gigabit Ethernet standards activity. Progress on this project will be communicated to the IEEE via liaisons.

ITU-T SG15 - OTU4

ITU-T SG15 is working closely with the IEEE to create a new transmission rate and signal format to accommodate transport of the 100 GbE signal. A new level of the OTN hierarchy is under development for this purpose, identified as the OTU4 signal. The OTU4 signal will additionally support a multiplex of lower rate OTN signals. We will base our work in this project on the assumption that we will transport an ODU4 payload signal, wrapped into an OTU4 frame, including the OTU4 FAS (frame alignment signal).

In the OTN there is provision for use of proprietary Forward Error Correction (FEC) codes as part of the OTU overhead. We anticipate significant challenges in achieving the distance and spectral efficiency goals the market has set for the transport of 100G signals, and will examine improved FEC approaches to achieve additional system margin. We recognize that the ITU-T has responsibility for standardization of FEC, and we will provide the results of our work to them for their consideration.

Our approach to 100 G transport is based on a coherent receiver using digital signal processing technology. As part of this project we will examine the need for specific signal adaptation or overhead introduction required for this approach. While such technology specific requirements may not be appropriate for standardization by the ITU-T, we will keep them informed of our progress in this area.

Summary

Network customers and service providers have communicated their needs for 100G transport technology in wide area networks. Besides the need for speed, solutions need to meet stringent transmission performance objectives while yielding improvements in cost, space and power dissipation per bit in comparison with today's 10G and 40G transmission solutions. At the same time many customers require compatibility with existing DWDM systems. These requirements can be met with the aggressive application of new technologies, in the form of advanced modulation formats, coherent receiver technology, photonic integration and improved forward error correction coding. These technology developments require substantial investment across the entire supply chain, from components, to modules and subsystems, and to systems. The OIF has played a key role in coordinating industry efforts towards a number of key technology building blocks whose creation will pave the way for high performance, cost effective solutions while preserving the ability of system vendors to continue to innovate.

This paper is the collaborative effort of many members of the OIF, including:

Joe Berthold, Ciena
Jeff Hutchins, CoreOptics
Karl Gass, Sandia National Laboratories
David R Stauffer, IBM Microelectronics
Ted Schmidt, Opnext
Francesco Caggioni, AMCC
Torsten Wuth, Nokia Siemens Networks