



## **Integrable Tunable Laser Assembly MSA**

OIF-ITLA-MSA-01.2

*June 26, 2008*

Implementation Agreement created and approved  
by the Optical Internetworking Forum  
[www.oiforum.com](http://www.oiforum.com)



---

**The OIF is an international non profit organization with over 80 member companies, including the world's leading carriers and vendors. Being an industry group uniting representatives of the data and optical worlds, OIF's purpose is to accelerate the deployment of interoperable, cost-effective and robust optical internetworks and their associated technologies. Optical internetworks are data networks composed of routers and data switches interconnected by optical networking elements. With the goal of promoting worldwide compatibility of optical internetworking products, the OIF actively supports and extends the work of national and international standards bodies. Working relationships or formal liaisons have been established with IEEE 802.1, IEEE 802.3ba, IETF, IP-MPLS Forum, IPv6 Forum, ITU-SG13, ITU-T SG15, MEF, ATIS-OPTXS, ATIS-TMOC, TMF and the XFP MSA Group.**

For additional information contact:  
The Optical Internetworking Forum, 48377 Fremont Blvd.,  
Suite 117, Fremont, CA 94538  
510-492-4040 (F) [info@oiforum.com](mailto:info@oiforum.com)  
[www.oiforum.com](http://www.oiforum.com)

**Notice:** This Technical Document has been created by the Optical Internetworking Forum (OIF). This document is offered to the OIF Membership solely as a basis for agreement and is not a binding proposal on the companies listed as resources above. The OIF reserves the rights to at any time to add, amend, or withdraw statements contained herein. Nothing in this document is in any way binding on the OIF or any of its members. The user's attention is called to the possibility that implementation of the OIF implementation agreement contained herein may require the use of inventions covered by the patent rights held by third parties. By publication of this OIF implementation agreement, the OIF makes no representation or warranty whatsoever, whether expressed or implied, that implementation of the specification will not infringe any third party rights, nor does the OIF make any representation or warranty whatsoever, whether expressed or implied, with respect to any claim that has been or may be asserted by any third party, the validity of any patent rights related to any such claim, or the extent to which a license to use any such rights may or may not be available or the terms hereof.

© 2001 Optical Internetworking Forum

This document and translations of it may be copied and furnished to others, and derivative works that comment on or otherwise explain it or assist in its implementation may be prepared, copied, published and distributed, in whole or in part, without restriction other than the following, (1) the above copyright notice and this paragraph must be included on all such copies and derivative works, and (2) this document itself may not be modified in any way, such as by removing the copyright notice or references to the OIF, except as needed for the purpose of developing OIF Implementation Agreements.

By downloading, copying, or using this document in any manner, the user consents to the terms and conditions of this notice. Unless the terms and conditions of this notice are breached by the user, the limited permissions granted above are perpetual and will not be revoked by the OIF or its successors or assigns.

This document and the information contained herein is provided on an "AS IS" basis and THE OIF DISCLAIMS ALL WARRANTIES, EXPRESS OR IMPLIED, INCLUDING BUT NOT LIMITED TO ANY WARRANTY THAT THE USE OF THE INFORMATION HEREIN WILL NOT INFRINGE ANY RIGHTS OR ANY IMPLIED WARRANTIES OF MERCHANTABILITY, TITLE OR FITNESS FOR A PARTICULAR PURPOSE.

# 1 Table of Contents

1	Table of Contents .....	3
2	List of Tables .....	6
3	List of Figures .....	7
4	Document Revision History .....	8
5	References and Conventions .....	11
5.1	External Reference Documents .....	11
5.2	Conventions Used in This Document .....	11
6	Introduction .....	13
6.1	Scope .....	13
6.2	Background .....	13
6.3	Communication Overview .....	14
6.3.1	Physical Interfaces .....	15
6.4	Command Overview .....	15
6.4.1	Command Execution Overlap .....	15
6.4.2	Extended Addressing .....	16
6.4.3	Data Types .....	17
6.4.3.1	Two Byte Data Values .....	17
6.4.3.2	Multi-byte Fields .....	17
6.4.4	Execution Error Field Conditions .....	17
6.5	Command & Module Features .....	17
6.5.1	Module Reset .....	17
6.5.2	Communication Error Detection .....	18
6.5.2.1	Detection by Module .....	18
6.5.2.2	Detection by Host .....	18
6.5.3	Execution Error Detection .....	18
6.5.4	Module Signaling Line .....	18
6.5.5	Non-Volatile Default Configuration .....	18
7	Physical Layer & Electrical Characteristics .....	19
7.1	Assembly Electrical Interface .....	19
7.1.1	Electrical Connector on User's Board .....	19
7.1.2	Pin Assignments .....	19
7.1.3	Electrical Characteristics .....	22
7.2	Communication Interface .....	24
7.2.1	RS232 Communications Interface .....	24
8	Transport Layer .....	27
8.1	Overview .....	27
8.2	Checksum .....	27
9	Command Interface (Application Layer) .....	29
9.1	Command Format .....	29
9.1.1	In-Bound (Host to Module) .....	29
9.1.2	Out-Bound (Module to Host) .....	29
9.2	Register Summary .....	31
9.3	Command Description Format .....	34
9.4	Generic Module Commands .....	36
9.4.1	NOP/Status (NOP 0x00) [RW] .....	36
9.4.2	Device Type (DevTyp 0x01) [R] .....	37
9.4.3	Manufacturer (MFGR 0x02) [R] .....	38
9.4.4	Model (Model 0x03) [R] .....	38
9.4.5	Serial Number (SerNo 0x04) [R] .....	39
9.4.6	Manufacturing Date (MFGDate0x05) [R] .....	40
9.4.7	Release (Release 0x06) [R] .....	41
9.4.8	Release Backwards Compatibility (RelBack 0x07) [R] .....	43

9.4.9	General Module Configuration (GenCfg 0x08) [RW]	44
9.4.10	IO Capabilities (IOCap 0x0D) [RW]	45
9.4.11	Extended Addressing Mode Registers (0x09-0x0B, 0x0E-0x10) [RW]	45
9.4.11.1	Extended Address Configuration (EAC 0x09 & 0x0E)	47
9.4.11.2	Extended Address (EA 0x0A & 0x0F)	48
9.4.11.3	Extended Address Access Register (EAR 0x0B & 0x10)	48
9.4.12	Last Response (LstResp 0x13) [R]	48
9.4.13	Download Configuration (DLConfig 0x14) [RW]	50
9.4.14	Download Status (DLStatus 0x15) [R]	53
9.5	Module Status Commands	54
9.5.1	StatusF, StatusW (0x20, 0x21) [RW]	54
9.5.2	Power Threshold (FPowTh, WPowTh 0x22, 0x23) [RW]	58
9.5.3	Frequency Threshold (FFreqTh, WFreqTh 0x24, 0x25) [RW]	59
9.5.4	Thermal Threshold (FThermTh, WThermTh 0x26, 0x27) [RW]	60
9.5.5	SRQ* Triggers (SRQT 0x28) [RW]	61
9.5.6	FATAL Triggers (FatalT 0x29) [RW]	62
9.5.7	ALM Triggers (ALMT 0x2A) [RW]	63
9.6	Module Optical Settings	64
9.6.1	Channel (Channel 0x30) [RW]	64
9.6.2	Optical Power Set Point (PWR 0x31) [RW]	66
9.6.3	Reset/Enable (ResEna 0x32) [RW]	67
9.6.4	Module Configuration Behavior (MCB 0x33) [RW]	69
9.6.5	Grid Spacing (Grid 0x34) [RW]	70
9.6.6	First Channel's Frequency (FCF1, FCF2 0x35 – 0x36) [RW]	71
9.6.7	Laser Frequency (LF1, LF2 0x40 – 0x41) [R]	72
9.6.8	Optical Output Power (OOP 0x42) [R]	73
9.6.9	Current Temperature (CTemp 0x43) [R]	73
9.7	Module's Capabilities	74
9.7.1	Fine Tune Frequency Range (FTF 0x4F) [R]	74
9.7.2	Optical Power Min/Max Set Points (OPSL, OPSH 0x50 – 0x51) [R]	75
9.7.3	Laser's First/Last Frequency (LFL1/2, LFH1/2 0x52-0x55) [R]	76
9.7.4	Laser's Minimum Grid Spacing (LGrid 0x56) [R]	77
9.8	MSA Commands	78
9.8.1	Module Currents (Currents 0x57) [R]	78
9.8.2	Module Temperatures (Temps 0x58) [R]	79
9.8.3	Digital Dither (Dither(E,R,A,F) 0x59-0x5C) [RW] [Optional]	80
9.8.4	TBTF Warning Limits (TBTF_L, TBTF_H 0x5D, 0x5E) [RW]	82
9.8.5	Age Threshold (FAgeTh, WAgeTh 0x5F, 0x60) [RW]	83
9.8.6	Laser Age (Age 0x61) [R]	84
9.8.7	Fine Tune Frequency (FTF 0x62) [RW]	85
9.9	Manufacturer Specific (0x80-0xFE)	86
10	Alarm and Status Register Behavior	87
10.1	Introduction	87
10.2	StatusF/StatusW Register Definitions	87
10.3	Status Bit Determination Conditions and Behavior	88
10.4	Effects of Alarm During Tuning (ADT) bit in MCB register (0x33)	90
11	Optical Specifications	92
11.1	Optical Characteristics	92
11.1.1	Optical Parameter Definitions	92
11.1.1.1	Frequency Tuning Range	92
11.1.1.2	Fiber Output Power	92
11.1.1.3	Output Power Variation Across Tuning Range	92
11.1.1.4	Frequency Error to the ITU Grid	92
11.1.1.5	Spectral Linewidth	92
11.1.1.6	SMSR (Side Mode Suppression Ratio)	92

11.1.1.7	RIN (Relative Intensity Noise) .....	92
11.1.1.8	Source Spontaneous Emission .....	93
11.1.1.9	Polarization Extinction Ratio .....	93
11.1.1.10	Optical Attenuation .....	93
11.1.2	Application Requirement 1 (Ultra Long Haul) .....	94
11.1.3	Application Requirement 2 (Long Haul) .....	95
11.1.4	Application Requirement 3 (Metro) .....	96
11.2	Timing Specifications .....	97
11.3	Module Warm Up Time .....	97
11.4	Frequency and Optical Power Transient Specifications .....	97
12	Mechanical Specifications .....	99
12.1	Integrable Assembly Mechanical Outline Dimensions .....	99
13	Appendix A: Open Issues / Current Work Items .....	101
14	Appendix B: List of Companies and Contributors .....	101
14.1	Technical Contributors (to the Original Document) .....	101
14.2	List of OIF Member Companies (at time of adoption) .....	101
15	Document Index .....	102

## 2 List of Tables

Table 6.4-1: Example Reading Module Status .....	15
Table 6.4-2: Extended Address Register Description .....	16
Table 6.4-3: Extended Address Register READ Example .....	16
Table 7.1-1 Pin Assignments.....	19
Table 7.1-2 Pin Functions.....	20
Table 7.1-3: Electrical Characteristics .....	22
Table 7.1-4: Absolute Maximum Ratings .....	23
Table 7.2-1: Communication Byte Numbering .....	24
Table 7.2-2 RS232 Physical Interface Pins .....	24
Table 9.1-1: Packet Status Flags .....	29
Table 9.2-1: Table of Registers (Commands) .....	31
Table 9.4-1 Extended Address Space Mode Selection (EAM) .....	48
Table 9.4-2 Firmware Download Example .....	50
Table 9.4-3 Firmware Upload Example .....	51
Table 10.2-1: Status Fatal register 0x20 (StatusF) description .....	87
Table 10.2-2: Status Warning register 0x21 (StatusW) description .....	87
Table 10.2-3: SRQ Trigger register 0x28 (SRQT) description .....	88
Table 10.2-4: Fatal Trigger register 0x29 (FATALT) description.....	88
Table 10.2-5: Alarm Trigger register 0x2A (ALMT) description.....	88
Table 10.3-1: Determination conditions for each bit in the status register .....	88
Table 11.1-1: Optical Specification Requirement Matrix .....	92
Table 11.1-2: Optical Specifications (Application 1).....	94
Table 11.1-3: Optical Specifications (Application 2).....	95
Table 11.1-4: Optical Specifications (Application 3).....	96
Table 11.2-1: Timing Specifications .....	97
Table 11.3-1: Module Warm Up Time .....	97

### 3 List of Figures

Figure 6.3-1: Three Layer Communication Diagram .....	14
Figure 6.4-1: Paradigms for Module Control .....	15
Figure 7.2-1: RS232 Timing .....	25
Figure 7.2-2: RS232 Communication or Execution Error Timing .....	25
Figure 8.1-1: In-Bound (Host to Module) Frame .....	27
Figure 8.1-2: Out-Bound (Module to Host) Frame.....	27
Figure 8.1-3: Transport Layer Field Definitions .....	27
Figure 11.4-1: Frequency and power transient mask. $t_1$ is manufacturer specific. ....	98
Figure 12.1-1: Mechanical Outline Dimensions.....	99
Figure 12.1-2: Mechanical Dimensions .....	100

## 4 Document Revision History

Version	Date	Description
OIF-ITLAMS-01.0 Initial release	30 June 2004	Initial release
OIF-ITLAMS-01.1	22 November 2005	<p>Includes approved edits from oif2004.287.02 into working list.</p> <ul style="list-style-type: none"> <li>Modified <b>Error! Reference source not found.</b> removing the thread specification (Comment 1) for the transponder housing.</li> <li>Added LstRsp bit in Figure 8.1-1 and Figure 8.1-3. Added description in Section 6.5.2.2. Marked LstResp as deprecated in Table 9.2-1. Elaborated on use of LstRsp bit in Section 9.4.12.</li> </ul> <p>Includes updates from OIF2005.033.00:</p> <ul style="list-style-type: none"> <li>Add heat sink footnote in Table 7.1-4.</li> <li>Renamed FW to Release in Table 9.2-1.</li> <li>Corrected units from dBm to dB for F/WPowTh in Table 9.2-1.</li> <li>Changed de-asserted to asserted in 9.5.7 for clarification and consistency.</li> <li>Changed bit 26 of out bound frame in Figure 8.1-2 to 1 which is consistent with TL-MSA.</li> <li>Errata: fixed unsigned to signed for Registers 9.8.1 and 9.8.2.</li> <li>Modified connectors from FTM/CLM to ASP equivalents for GR1217 metallurgical compliance in 7.1.1. FTM-107-03-*-DV replaced with ASP-115915-01. CLM-107-02-*-D replaced with ASP-113466-01.</li> <li>Modified SSE units from dBc/nm to dBc in 11.1.2, 11.1.3, and 11.1.4.</li> <li>Updated figures in section 12.1 for the 18.29mm flex connector length and added additional views for clarity.</li> </ul> <p>Changed Sparing Frequency Tuning Time Specification 11.2 from 15s to 30s. Changed Section 11.3 Module Warm Up Time from 30s to 60s.</p> <p>Modified references section replacing G.692 to G694.1 as DWDM ITU description has been moved.</p> <p>Modified minimum frequency to 186.0 THz in Sections 11.1.2.1, 11.1.3.1, and 11.1.4.1. Modified respective footnotes 49, 51, and 53 to state frequency range is informative not normative.</p> <p>9.4.10 under detailed description – the word ‘then’ changed to ‘when’.</p> <p>9.4.13 Data Value Description – removed duplicate number 12, and replaced it with 13.</p> <p>9.7.4 added ‘[R]’ in title (since it is read only).</p> <p>9.8.6 In detailed description clarified that age is an ‘unsigned’ integer.</p> <p>9.8.2 – change the word currents to temperatures and unsigned to signed.</p>



OIF-ITLAMSA-01.2	26 June 2008	<p>Added DitherAA pin. See 7.1.2, Table 7.1-2, Table 7.1-3.</p> <p>Added FTF register (0x62) in Table 9.2.</p> <p>Added Section 9.8.7, FTF (0x62) register.</p> <p>Modified equations in Sections 9.6.7 (LF1/LF2), 9.6.1 (Channel), 9.6.5 (Grid) to include FTF setting, and scaled all units in equation to GHz.</p> <p>Added FTFR register (0x4F) in Table 9.2.</p> <p>Added Section 9.7.1, FTFR (0x4F) register.</p> <p>Added Section 11.4, frequency and optical power transient specifications</p> <p>Fixed row numbering in Table 6.4-3.</p> <p>Fixed row numbering in 9.4.2.</p> <p>Corrected data value description in Section 9.5.4 from 0x25/0x24 to 0x27/0x26.</p> <p>Updated index reference in Section 9.4.1, for MRDY bit in NOP register.</p> <p>Updated electrical connectors to CLM-107-02-H-D-K-TR and ASP-124330-02 in Section 7.1.1 and 12.</p> <p>Added 2mm minimum bend radius to mechanical drawing in Section 12.1.</p> <p>Added protocol version and up revision to 2.0.0 on Page 10. Revised PV version number in example in Section 9.4.7, Release register, to 2.0.0.</p> <p>Deleted CRC-16 section and all references to [W/R]CRC as command had been deprecated in previous release.</p> <p>Removed User Data Storage (0xFF) register as command was deprecated in previous release.</p> <p>Removed Lock register (0x16) and all references to lock.</p> <p>Fixed typo in Section 9.6.6 (FCF1/FCF2) where text referred incorrectly to LF1/2 when it should be FCF1/2.</p> <p>Added Section 10 describing the behavior of alarm and status registers.</p> <p>Modified all references to ALM* and FATAL* to either pointing to software bits ALM, FATAL respectively or removing reference as hardware lines do not exist in this MSA (only in tunable laser MSA).</p> <p>Modified Sections 9.5.7 (ALMT) and 9.6.4 (MCB) recommendation from 0x0504 to 0x0700 as fatal bits do not assert during tuning.</p> <p>Clarified DLStatus 9.4.14 to state that IS_VALID is set once both TYPE and INIT_CHECK are asserted. Statement added : "and with "INIT_CHECK" equal to 1."</p> <p>Removed non-volatile support for gencfg register as CRC-16 no longer supported. See Section 9.2 and 9.4.9.</p> <p>Clarified that Laser Age can be a trigger condition in the alarms (Section 9.5.1).</p> <p>Removed text: "This is latched and cleared by SENA. " in Sections 9.6.1 and 9.6.3 also changed "Note that changing the DIS* pin to high will not cause a tune" to "Note that changing the DIS* pin to high will not re-enable the output."</p> <p>Clarified Digital Dither Enable as 1 bit in Section 9.8.3.</p> <p>Corrected SRQT register value in Synopsis from 0x26 to correct value 0x28.</p> <p>Added word "Suggested:" to default content values for SRQT, ALMT, FATALT as these registers have manufacturer specific default values.</p> <p>Removed manufacturer specific for 9.6.4 (MCB). It is now default. Value is 0x02</p> <p>In Channel, made   to    ((Fatal_Status &amp; Fatal_Trigger) &amp;&amp; SDF)    ~SENA    ~DIS and in RESENA register.</p> <p>Removed invalid references in ITLA-MSA-01.1 revision history. References were made to deprecated commands and no longer valid as they have been removed.</p> <p>Clarified that the PWR command can have variable adjustment and that CIE is issued when tuned if command is traffic interrupting.</p> <p>Add the logical operators and bitwise operators to the "Conventions Used in this Document" section.</p> <p>Moved LstRsp bit to be part of transport layer to be self consistent in Section 9.1.1 In-Bound (Host to Module).</p> <p>Corrected typo in Table 7.1-2 that Pins 1,3 are tied together on 3.3V line instead of pins 1,2.</p> <p>Corrected typo in Figure 8.1-3 where 28 bits were referred to when actually 27 bits (26:0) are to be framed.</p> <p>Corrected typo in Table 9.1-1 where status bits were incorrectly referenced as bits 1:0 instead of 25:24.</p>
------------------	--------------	--

---

**Working Group:** Physical Link Layer

---

**TITLE:** Integrable Tunable Laser Assembly MSA (ITLA-MSA)

---

<b>SOURCE:</b>	<b>Raj Batra</b> Technical Editor Emcore Corporation 8674 Thornton Avenue Newark, CA 94560 Phone: 510 896 2072 Email: <a href="mailto:raj_batra@emcore.com">raj_batra@emcore.com</a>	<b>Karl Gass</b> Working Group Chair Sandia National Laboratories P.O. Box 5800 MS-0874 Albuquerque, NM 87185 Phone: 505 844 8849 Email: <a href="mailto:kgass@sandia.gov">kgass@sandia.gov</a>
----------------	--	---

---

**DATE:** 26 June 2008  
**PROTOCOL VERSION:** PV:2.0.0

---

**Project Name:** Integrable Tunable Laser Assembly MSA (ITLA-MSA)  
**Project Number:** OIF-0013  
**Project Abstract:** This contribution contains the updated changes to MSA-IA-01.0 for the *Integrable Tunable Laser Assembly* (ITLA) for integration into a 300-pin 3.5"x4.5" transponder. The changes incorporated are from oif2005.128.04 as approved in the technical committee principal ballot oif2005.372.00.

---

## 5 References and Conventions

### 5.1 External Reference Documents

The following documents should be read in conjunction with this specification

OIF-TLMSA-01.0	OIF Tunable Laser MSA Implementation Agreement ( <a href="http://www.oiforum.com">www.oiforum.com</a> )
300 Pin MSA	1) Reference Document for 300 PIN 10Gb Transponder 2) Reference Document for 300 PIN 40Gb Transponder 3) I <sup>2</sup> C Reference Document for 300 Pin MSA 10G and 40G Transponder
GR-468 CORE	General Reliability Assurance Requirements for Optoelectronic Devices Used in Telecommunications Equipment
CENELEC	EN50081-1 Electromagnetic Compatibility – Generic Emissions Standard part 1: Residential, Commercial and Light Industry EN50082-1 Electromagnetic Compatibility – Generic Immunity Standard part 1: Residential, Commercial and Light Industry EN50081-1 Electromagnetic Compatibility – Generic Emissions Standard part 2: Residential, Commercial and Light Industry
EIA RS-232D	The RS232 Bus Specification
21CFR1040.10	Laser Safety
IEC 60825-1	Safety Of Laser Products Part1: Equipment Classification, Requirements and Users Guide
G.694.1	Spectral grids for WDM applications: DWDM frequency grid

### 5.2 Conventions Used in This Document

#### Numeric Values:

5, 05	Decimal
0x05	Hexadecimal

#### Bit Numbering

Bit 0 is LSB<sup>1</sup>

#### Operators

&	bitwise AND
&&	logical AND
	bitwise OR
	logical OR
^	bitwise exclusive OR
~	bitwise not
>>	right bit shift operator

#### Data Types

Unsigned short int	16 bit, big endian
Signed short int	15 bit + 1, two's complement, big endian
Character	7-bit ASCII character (0x00 to 0x7F) (\0 is the null character)
Printable character	(0x20 to 0x7E)
String (ASCII)	All strings are null terminated string (first character bits are 15:8)

<sup>1</sup> LSB: Least significant bit

Data Direction

Out-bound	Module to host transfer (Response packet)
In-bound	Host to module transfer (Command from host)

Module

Module	Refers to the integrable assembly as a module.
--------	--

Transponder

Base	Portion of housing to which external heat sink is attached
Lid	Portion of housing with opening for 300 pin connector

## 6 Introduction

### 6.1 Scope

This document is a Multi-Source Agreement for integrable tunable laser assemblies. It details a communication protocol, electrical interface, power supply, optical specifications, and a mechanical interface for use in telecommunications equipment operating in the C or L band.

### 6.2 Background

The OIF has completed two tunable laser projects. The first project resulted in the *Tunable Laser Implementation Agreement*, OIF-TL-01.1 began in April 2001 and was released in November 2002. A large number of contributors from a wide variety of consumers and suppliers of tunable lasers were involved in contributing and reviewing the first Implementation Agreement. It addressed the communication protocol, electrical interface and mechanical form factor interoperability for tunable continuous wavelength (CW) lasers. The document serves as a roadmap for future tunable device implementation agreements.

In February 2003, the OIF began a new fast track project, the *Tunable Laser MSA Implementation Agreement*. This MSA-IA builds upon the existing *Tunable Laser Implementation Agreement*, generating a more comprehensive specification of the optical, electrical, mechanical, and communication protocols. It was completed in May 2003.

In October 2003, the OIF began a new project, the Integrable Tunable Laser Assembly (ITLA) MSA Implementation Agreement to focus on standardization of a CW laser subassembly for integration into transponders for both the 3.5"x4.5" transponder as well as the small form factor transponder.

The OIF-IAs can be found at [www.oiforum.com](http://www.oiforum.com) as document [OIF-TL-01.1.pdf](http://www.oiforum.com/public/documents/OIF-TL-01.1.pdf) at <http://www.oiforum.com/public/documents/OIF-TL-01.1.pdf> and [OIF-TLMSA-01.0.pdf](http://www.oiforum.com/public/documents/OIF-TLMSA-01.0.pdf) at <http://www.oiforum.com/public/documents/OIF-TLMSA-01.0.pdf>.

### 6.3 Communication Overview

The following diagram (Figure 6.3-1) depicts the communication process.

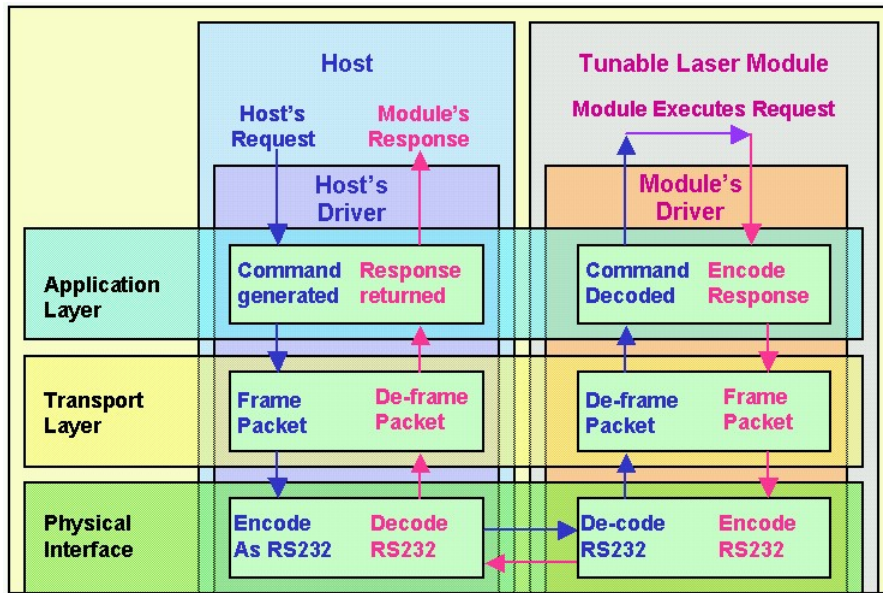


Figure 6.3-1: Three Layer Communication Diagram

Assume the host has a request to transmit to the module (Host's Request). The request is first encoded as a 28-bit command packet in the Host Driver's application layer. The command is then framed as a 32-bit packet in the host driver's transport layer. The framing operation includes the addition of a BIP-4<sup>2</sup> checksum. Finally, the host driver's physical interface (RS232 shown) encodes the 32 bit packet as 4 ten bit<sup>3</sup> RS232 "characters" and transmits in across the TxD line to the module.

The module's physical layer receives 40 bits and de-codes them by removing the RS232 start and stop bits. The resulting 32-bit frame is delivered to the transport layer where checksum is checked for consistency. Assuming no error is generated, the 28-bit command packet is delivered to the module's application layer where the command is decoded and executed.

The command execution will generate a response when complete<sup>4</sup>. The response packet consists of 26 bits.

The response packet is delivered to the module's transport layer which frames the packet by pre-pending a checksum, communication error (CE). The resulting 32-bit packet is then delivered to the module's physical layer where it is then encoded as 40 bits.

The host then receives the 4 RS232 characters and performs the inverse operations as the packet moves up the host's layer hierarchy.

<sup>2</sup> Bit Interleaved Parity (4 bits)

<sup>3</sup> Note each byte to be transmitted by RS232 is encapsulated by a start and stop bit thus pre-pending 1 bit and post-pending 1 bit for a total of 10 bits for each byte to be transmitted.

<sup>4</sup> Note that an initial response may also be generated for commands whose execution time exceeds the command response timeout period. The host can either poll for completion of the command or have pre-configured the module to issue a service request (SRQ) upon completion of the command.

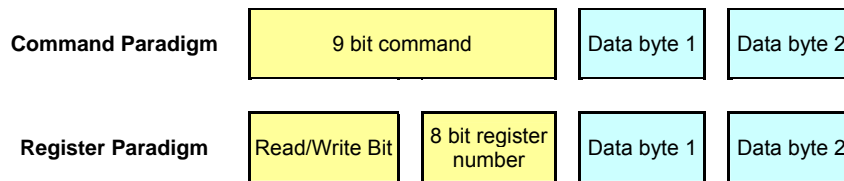
### 6.3.1 Physical Interfaces

The communications interface supports only one physical layer protocol, RS232.

## 6.4 Command Overview

The commands to the module consist of a 9-bit operation followed by 2 bytes of optional data. Alternatively, the command can be thought of as one read/write bit followed by an 8-bit register number followed by 2 bytes of optional data. See Figure 6.4-1. The register paradigm will be used in this document.

Figure 6.4-1: Paradigms for Module Control



There are 256 directly accessible registers (0x00 to 0xFF) in the primary register address space. The OIF-IA allocates the first 32 registers (0x00 to 0x1F) for generic module operations for all module types. Another 96 registers (0x20-0x7f) are reserved for device type “CW Laser Int Assy”. Finally, the remaining 128 registers (0x80-0xFF) are provided as manufacturing specific registers.

The following example shows how the module’s status would be read.

Table 6.4-1: Example Reading Module Status

#	Command (Host to Module)			Response (Module to Host)		
	Operation	Register	Data Bytes (15:0)	Status	Register	Data Bytes (15:0)
1	Read	0x20 (StatusF)	0x0000	0x00 (Ok)	0x20 (StatusF)	0x0000
Note: Example shows that the module status is 0x0000 as returned in the response data.						

### 6.4.1 Command Execution Overlap

The application layer provides support for pending operations especially useful for operations that can take a significant period of time to complete<sup>5</sup>.

If a command is issued to the module that results in a long time to complete, the module will return a response packet within the specified time out period for the module and flag the operation as pending<sup>6</sup>. The interface is now free to respond to additional commands. The host can determine when the pending operation completes by polling the NOP register (0x00). The NOP register returns the pending operation status as well as any error conditions. Note that the module can be configured to generate an SRQ (Service Request) when a pending operation terminates operation in an error state. See §9.4.1 and §9.1.2.

<sup>5</sup> Channel tuning is an example of a command which can take from 5ms to 15s to achieve depending on laser technology utilized.

<sup>6</sup> Some other interfaces such as the 300-pin transponder MSA do not allow command execution overlap.

### 6.4.2 Extended Addressing

Extended addressing provides an additional memory space (22 address bits) in addition to the primary 256 registers (8-bit address space).

The extended addressing feature consists of three registers described in Table 6.4-2.

**Table 6.4-2: Extended Address Register Description**

Register	Description	Fields
Configuration	Defines basic configuration for the extended address	Defines the <ul style="list-style-type: none"> <li>▪ address space</li> <li>▪ high order address bits</li> </ul>
Address	Address of field in either physical or virtual memory space	Defines the 16 low order address bits
Contents	Reading from this register returns data stored in this field 16 bits at a time Write to this register stores data into this field 16 bits at a time	16 bit data value

Once the configuration and address registers are configured, the host may issue a series of read or write commands to the (indirect contents register) thereby accessing the memory location pointed to by the indirect register. The locations may map to physical or virtual memory spaces.

The configuration register and address registers are usually pre-configured when one of the primary registers is accessed which holds an object longer than a 16-bit integer.

For example, the device type of the laser is stored in register. The DevTyp register (0x01) requires the use of the extended address register. Table 6.4-3 shows an example where the DevTyp register is read and the module returns the 8-character string "CWITLA\0". The table shows a seventh entry showing what happens if the read extends beyond the available string length.

**Table 6.4-3: Extended Address Register READ Example**

#	Command (Host to Module)			Response (Module to Host)		
	Operation	Register	Data Bytes (15:0)	Status	Register	Data Bytes (15:0)
1	Read	0x01 (DevTyp)	0x0000	0x02 (AEA-flag)	0x01 DevTyp	0x0008 (# bytes in string)
Note: When the Read is completed, registers (0x09, and 0x0A) are configured to point to proper field.						
2	Read	0x0B (AEA-EAR)	0x0000	0x00	0x0B (AEA-EAR)	0x4357 ("CW")
3	Read	0x0B (AEA-EAR)	0x0000	0x00	0x0B (AEA-EAR)	0x2049 ("I")
4	Read	0x0B (AEA-EAR)	0x0000	0x00	0x0B (AEA-EAR)	0x544C ("TL")
5	Read	0x0B (AEA-EAR)	0x0000	0x00	0x0B (AEA-EAR)	0x4100 ("A\0")
6	Read	0x0B (AEA-EAR)	0x0000	0x01 (XE-flag)	0x0B (AEA-EAR)	0x0000

Writing to an extended address field is handled in much the same way. The initial write causes the configuration and address registers to be preset to the appropriate values. Writing to the extended address register then stores the 16 bit values sequentially into the field.



### 6.4.3 Data Types

All of the general registers hold 16-bit data values or serve as pointers to a sequence of bytes (extended addressing mode). All values are stored as big endian, two's complement<sup>7</sup>.

#### 6.4.3.1 Two Byte Data Values

Data is represented in the registers as either signed or unsigned 16 bit integers. Note that single byte values would be stored with the appropriate leading zeros.

Real values are stored with an implied decimal point location. For instance, the value "12.3 dBm" would be stored as 123<sub>10</sub> in a field and has an implied formatting of one decimal place.

#### 6.4.3.2 Multi-byte Fields

Fields holding data longer than 16 bits are stored as a sequence of bytes and accessed through the extended addressing register.

ASCII strings are terminated with a null. Note that the extended address register allows the host to read beyond a null termination but not beyond the maximum field size.

Integers, floats, or structures are stored as a sequence of bytes<sup>7</sup>.

### 6.4.4 Execution Error Field Conditions

The reason for an execution error (XE) can be determined by reading the NOP/Status register (NOP 0x00). Bits 3:0 encode the error field value. The following table describes the error conditions.

Error Field	Symbol	Meaning
0x00	OK	Ok, no errors
0x01	RNI	The addressed register is not implemented
0x02	RNW	Register not write-able; register cannot be written (read only)
0x03	RVE	Register value range error; writing register contents causes value range error; contents unchanged <sup>8</sup>
0x04	CIP	Command ignored due to pending operation
0x05	CII	Command ignored while module is initializing, warming up, or contains an invalid configuration
0x06	ERE	Extended address range error (address invalid)
0x07	ERO	Extended address is read only
0x08	EXF	Execution general failure
0x09	CIE	Command ignored while module's optical output is enabled (carrying traffic)
0x0A	IVC	Invalid configuration, command ignored
0x0A-0x0E	--	Reserved for future expansion
0x0F	VSE	Vendor specific error

## 6.5 Command & Module Features

### 6.5.1 Module Reset

The module provides four ways to accomplish reset.

Reset Technique	Resulting Action
-----------------	------------------

<sup>7</sup> For instance, the number 256<sub>10</sub> (0x0100) is stored as the byte sequence 0x01, 0x00. The string "HI" is stored as the series of bytes: 0x48 ('H'), 0x49 ('I'), 0x00 ('\0').

<sup>8</sup> Note that an RVE error can occur if a field can only take on certain discrete values and an invalid value is written. For instance, a particular module may only support 25GHz or 50GHz grid intervals. If an interval of 30GHz is written and is not supported, the module will return an RVE error code.

Hardware	Module Select (when MS* de-asserted and then re-asserted (specifically the low to high transition))	Clears communication input buffers, may reset baud rate to default (See §7.2.1). Does not affect AEA registers.
	Reset (RST* low)	Traffic interrupting – reboots module.
Software	ResEna (0x32) (SR Bit = 1)	Aborts transfers in progress (FW download, AEA transfers)
	ResEna (0x32) (MR Bit = 1)	Traffic interrupting – reboots module.

## 6.5.2 Communication Error Detection

Communication error detection occurs on the module and host sides of the communication interface.

### 6.5.2.1 Detection by Module

The module examines the in-bound packets (host to module) to see if the checksum (see §8.2) is consistent. An inconsistency results in a unprocessed response packet with the CE flag asserted in the out-bound packet.

When the host observes the CE flag, the last out-bound packet should be resent.

### 6.5.2.2 Detection by Host

The host examines the response packets for consistency by checking the checksum (see §8.2) for the out-bound packet (module to host). If the checksum is inconsistent, the host may request the module's last response to be retransmitted by setting the LstRsp bit in the Host to Module Packet. This can also be accomplished by reading the deprecated LstResp (0x13) register.

## 6.5.3 Execution Error Detection

Execution errors occur when the module is unable to execute the requested command. The module encodes the XE flag bit (execution error flag) in the response packet. When the host detects an XE flag in the response packet, it can read the NOP (0x00) register to determine the error field condition. The reasons for failure to execute a command are enumerated in §6.4.4-Execution Error Field Conditions.

## 6.5.4 Module Signaling Line

The module has one hardware line to signal its status, SRQ\*.

The SRQ\* line is used to signal fatal conditions, warning conditions, or other module service request needs such as an execution error (XE) for a command processing in the background (pending operation). The SRQ\* line, once asserted, remains asserted until the status register is cleared.

Alarm or fatal conditions can be determined by reading the status registers (See §9.5.1).

## 6.5.5 Non-Volatile Default Configuration

The command interface allows the current module configuration to be saved as the default configuration. The default configuration is restored upon hard reset (See §6.5.1 Module Reset) or upon power up. In the event of loss of power or hard reset during a save configuration request, the module's default configuration will remain unchanged. See (§9.4.9 General Module Configuration (GenCfg 0x08) [RW]).

## 7 Physical Layer & Electrical Characteristics

This section describes the electrical interfaces and the physical layer interface.

### 7.1 Assembly Electrical Interface

#### 7.1.1 Electrical Connector on User's Board

User's connector on transponder board: Samtec P/N CLM-107-02-H-D-K-TR<sup>9</sup> or equivalent.

Note: Connection from integrable assembly module made through flex-circuit cable with appropriate mating connector for the user's Samtec CLM-107-02-H-D-K-TR connector. The mating connector is ASP-124330-02<sup>10</sup> which is on the flex cable.

#### 7.1.2 Pin Assignments

The pin assignments shown in Table 7.1-1. The pin functions are described in Table 7.1-2.

Table 7.1-1 Pin Assignments

PIN Name	PIN #		PIN #	PIN Name
+3.3V Supply	1		2	DIS*
+3.3V Supply	3		4	SRQ*
Gnd	5		6	MS*
Gnd	7		8	TxD
-5.2 Supply	9		10	RxD
-5.2 Supply	11		12	RST*
OIF Reserved	13		14	DitherAA <sup>11</sup>

<sup>9</sup> This connector is equivalent to CLM 107-2-X-D with additional plating for GR1217 metallurgical compliance.

<sup>10</sup> This connector is equivalent to ASP-119097-01 and FTMH-107-03-\*-DV with different plating and/or thicknesses. The mating height is 4.06mm with FTMH-107-03-X-DV. The mating height is further increased by the technique used to attach a cable to the connector. The flexi-PCB could add 0.1mm to 0.2mm in additional height.

<sup>11</sup> Amplitude dither for trace tone functionality (TxTrace).

**Table 7.1-2 Pin Functions**

Pin Numbers	Symbol	Type	Name	Description
5,7	GND	Power	Ground	Ground <b>Note:</b> Ground pins are tied together internally to the module.
1,3	PS+3.3V	Power	+3.3V Supply	3.3V Power Supply <b>Note:</b> Pins are tied together internally to the module.
9,11	PS-5.2V	Power	-5.2V Supply	-5.2V Power Supply <b>Note:</b> Pins are tied together internally to the module.
12	RST*	LVTTL input, active low	Reset	<b>Purpose:</b> Disables laser output and holds the module in RESET <b>Initial State:</b> Any – user application specific <b>Action:</b> Laser OFF, TEC OFF, Module CPU held in RESET, Communication protocol is OFF <b>Resultant State:</b> High, Must remain high for laser to operate <b>Attributes:</b> When active, lowest current draw from the module.
2	DIS*	LVTTL input, active low	Disable module's optical output	<b>Purpose:</b> Provide hardware control to kill laser output. <b>Initial State:</b> Any – user application specific <b>Action:</b> High = laser output controlled by protocol; Low = laser output OFF <b>Resultant State:</b> When DIS* asserted, communication protocol is ON, software enable (SENA) reset. <b>Attributes:</b> Bypasses communication protocol to turn laser OFF. Re-enabling of the laser requires setting SENA. Otherwise does not interfere with module settings.
4	SRQ*	LVTTL output, active low	Programmable module service request	<b>Purpose:</b> General purpose service request. <b>Initial State:</b> High (No service requested) <b>Action:</b> Generates request for service as required to report a variety of conditions by setting line low. SRQ* is asserted when the result of the status (0x20,0x21) OR'd with SRQT trigger (0x28) is non-zero. <b>Resultant State:</b> · Communication protocol is ON · SRQ* conditions can be read and cleared through interface <b>Attributes:</b> SRQ conditions (and limits) are software configurable and can be re-configured by the user through the interface. Status bits must be cleared to de-assert SRQ*.

Pin Numbers	Symbol	Type	Name	Description
6	MS*	LVTTL input, active low-high transition	Module IO Select (Reset communications interface)	<b>Purpose:</b> Provide hardware control to reset physical interface <b>Initial State:</b> Any – user application specific <b>Action:</b> High or LOW = No effect; Low to High transition – Reset communications interface, clear input buffers, terminate current packet <b>Resultant State:</b> Communication can be commenced upon deassertion with a new packet. <b>Attributes:</b> Provides ability to reset communications interface
8	TxD	LVTTL output	Module's Transmit Data	<b>Purpose:</b> Transmit outbound packets from module
10	RxD	LVTTL input	Module's Receive Data	<b>Purpose:</b> Receive inbound packets from host
13	OIF Reserved	LVTTL input	OIF Reserved	<b>No user connection</b> <b>Purpose:</b> Provide for possible future expansion of communications interfaces
14	DitherAA	2.5V p-p sinusoidal, analog input	Dither amplitude analog signal	<b>Purpose:</b> Provide trace tone capability. AC coupled inside ITLA. Pull down to ground if not used.

### 7.1.3 Electrical Characteristics

**Table 7.1-3: Electrical Characteristics**

Parameter	Symbol	Min	Typ	Max	Unit
+3.3V Supply voltage	$V_{CC}$	3.15	3.30	3.45	V
+3.3V Supply current	$I_{CC}$			1500	mA (Peak <sup>12</sup> )
-5.2V Supply voltage	$V_{EE}$	-5.45	-5.20	-4.94	V
-5.2V Supply current	$I_{EE}$	-1200	-1000		mA (Peak <sup>13</sup> )
Power Dissipation <sup>14</sup>	$P_D$			6.6	W
Input voltage, low	$V_{IL}$	0.0		0.8	V
Input voltage, high	$V_{IH}$	2.0		3.45	V
Output voltage, low ( $I_{OL} = 4$ mA)	$V_{OL}$	0.0		0.6	V
Output voltage, high ( $I_{OH} = -4$ mA)	$V_{OH}$	2.4		$V_{CC}$	V
Power supply noise (for power supplied to the module) (100Hz to 20MHz)				1.0	%rms
Analog Amplitude dither (DitherAA) modulation voltage (peak to peak).		0	1.25	2.5	Vpp
Analog Amplitude dither input voltage range peak to peak swing. Accuracy is manufacturer specific.		0	5	10	%pp
Analog Amplitude dither (DitherAA) input impedance (AC coupled circuitry in ITLA)		10			k $\Omega$
				10	pF
Analog amplitude sinusoidal dither -3dB bandwidth		10		1000	kHz

<sup>12</sup> The instantaneous current cannot exceed 1.5 amps.

<sup>13</sup> The absolute value of the instantaneous current cannot exceed 1.2 amps.

<sup>14</sup> The dual supply configuration allows an ITLA to either draw all its power from a single supply or from both supplies as long as the total average power dissipation does not exceed  $P_D$ .

The module must be able to withstand the following conditions without permanent damage.

**Table 7.1-4: Absolute Maximum Ratings**

Parameter	Symbol	Min	Max	Unit
Operating 'base of butterfly' temperature range <sup>15</sup>	T <sub>BTF</sub>	-5	+70	°C
Total power dissipation			6.6	W
Storage temperature range	T <sub>STORE</sub>	-40	+85	°C
Storage relative humidity <sup>16</sup>	RH	5	95	%
Operating relative humidity <sup>16</sup>	RH	5	85	%
Signal pin voltage		-0.5	V <sub>CC</sub> + 0.3	V
Power Pin Voltage 3.3V supply		-0.3	3.6	V
Power Pin Voltage -5.2V supply		-5.5	+0.3	V

<sup>15</sup> Requires adequate heat sinking

<sup>16</sup> Non condensing

## 7.2 Communication Interface

The communications interface transfer the 32-bit packet with the high order byte (byte 1) transmitted first.

**Table 7.2-1: Communication Byte Numbering**

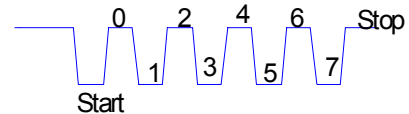
Byte 1	Byte 2	Byte 3	Byte 4
Bits 31:24	Bits 23:16	Bits 15:8	Bits 7:0

### 7.2.1 RS232 Communications Interface

The RS232 interface uses a 3-wire implementation (Tx, Rx + ground)<sup>17</sup>.

The default baud rate (for initial communication) is 9600 baud which remains in effect otherwise changed or reconfigured as a module default. The maximum supported baud rate is 115.2 kbaud.

The interface is configured as 8 bit, no parity, 1 stop bit, no echo, no flow control, and is fully capable of transferring binary data. The following figure shows the timing of a RS232 signal transmitting 0xAA. The LSB<sup>18</sup> is transmitted first.



The interface generates LVTTTL output signal levels.

The interface consists of the pins shown in the following table.

**Table 7.2-2 RS232 Physical Interface Pins**

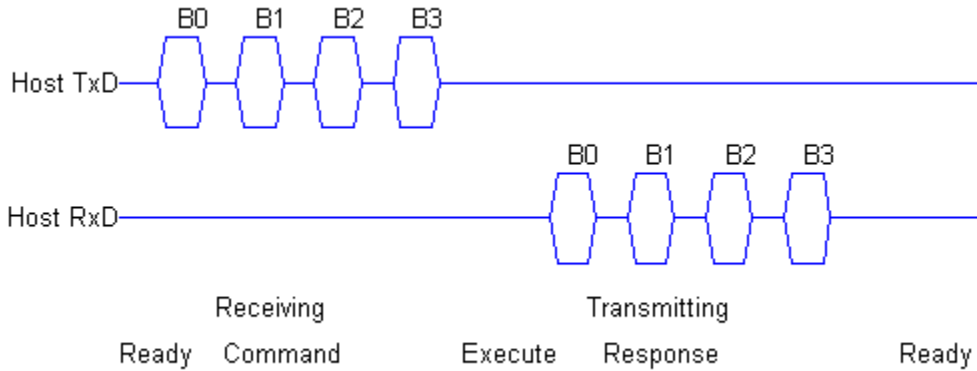
PIN	I/O	FUNCTION
RxD	input	LVTTTL serial input (break signal is 0v)
TxD	output	LVTTTL serial output (break signal is 0v)
Gnd	ground	Ground
MS*	input	LVTTTL Module Select (Used for RS232 Interface reset or tied low) Does not deselect the interface.

Figure 7.2-1 shows the interface timing. The MS\* line is used to synchronize packet framing of the RS232 interface. It can be used to reset the serial interface and clear the I/O buffers on a low to high transition. By default, a low to high transition on MS\* can be configured to reset the interface baud rate to the default. This behavior can be configured through the IOCAP register.

<sup>17</sup> This physical interface may be better described as an ASYNC interface but is usually referred to by the industry as an RS232 implementation.

<sup>18</sup> Least significant bit

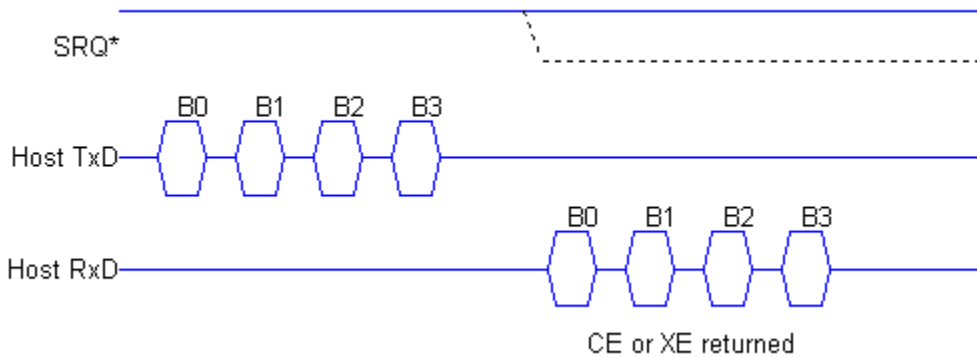




**Figure 7.2-1: RS232 Timing**

Note that de-asserting the MS\* line does not tri-state the Tx line.

The following figure (Figure 7.2-2) also shows a case in which a CE or XE (communications error or execution error) is asserted. For the default configuration on the RS232 interface, the SRQ\* line is asserted for execution errors from pending operations<sup>19</sup>. The conditions for which the SRQ\* line is asserted are configurable. See (SRQ\* Trigger register (0x28)).



**Figure 7.2-2: RS232 Communication or Execution Error Timing**

The IOCap register has the following format and assumes default values upon power up or hardware reset.

<sup>19</sup> By default, non-pending operations which result in an execution error do not assert SRQ.

15	14	13	12	11	10	9	8	7	6	5	4	3	2	1	0
0x0			RMS	0x0			Reserved (0x0)	Current Baud Rate				Supported Baud Rates			

Bits 0-3 – Maximum baud rate supported by the module<sup>20</sup>. (Not writable)

- 0x00 – 9600
- 0x01 – 19200
- 0x02 – 38400
- 0x03 – 57600
- 0x04 – 115200
- 0x05 – 0x0F – Undefined

Bits 4-7 – The module's currently configured baud rate (writable) (default 0x00)

- 0x00 – 9600
- 0x01 – 19200
- 0x02 – 38400
- 0x03 – 57600
- 0x04 – 115200
- 0x05 – 0x0F – Undefined

Bit 8 – Reserved (0x0).

Bits 9-11 Reserved

Bits 12 – RMS - Configurable action upon low to high transition of MS\*

- 0x0 – Baud rate will be reset to default (0x00) and input buffer cleared upon low to high transition of MS\* (default).
- 0x1 – Clear the input buffers but do not reset the baud rate.

Bits 14-15 – Reserved (default 0x00)

<sup>20</sup> The assumption is that the module will support all RS232 baud rates shown in the table to the specified maximum baud rate.

## 8 Transport Layer

### 8.1 Overview

The transport layer encapsulates the command and response packets to form a 32-bit frame. Figure 8.1-1 and Figure 8.1-2 depict the in-bound and out-bound frames. The transport layer is responsible for the fields in white. The application layer is responsible for the shaded fields below.

Note that the high order bit (left most bit) is numbered 31.

**Figure 8.1-1: In-Bound (Host to Module) Frame**

31	30	29	28	27	Bits 26:0					
Checksum				LstRsp	Command packet being framed					

**Figure 8.1-2: Out-Bound (Module to Host) Frame**

31	30	29	28	27	26	Bits 25:0				
Checksum				CE	1	Response packet being framed				

**Figure 8.1-3: Transport Layer Field Definitions**

Field	In-Bound (Host to Module)	Out-Bound (Module to Host)
Application Layer Packet to be Framed	27 bits Bits 26:0	26 bits Bits 25:0
Checksum Bits 31:28	BIP-4 checksum computed over a 32 bit word with the leading 4 bits pre-pended to the 28 bit packet and set to zero.	BIP-4 checksum computed over a 32 bit word with the bits 31:28 set to zero and bits 27:26 defined by the transport layer prior to the BIP-4 computation.
LstRsp/CE Bit 27 (Communication Error)	Bit set to logic 0 when the checksum is consistent. Bit set to logic 1 forces module to resend last valid packet. Used when the checksum is inconsistent.	Bit set to logic 0 when the checksum is consistent. Bit set to logic 1 when the checksum is inconsistent.

Each in-bound and out-bound packet contains a 4 bit checksum. The checksum is computed over all the bits being encapsulated using a BIP-4 checksum.

### 8.2 Checksum

The checksum is a BIP-4<sup>21</sup> checksum is computed by xor'ing all the bytes in the packet together and then xor'ing the left nibble of the result with the right nibble of the result. The checksum provides a basic level of consistency check for the communications transfer.

```

unsigned char calcBIP4( unsigned char* data ) {
    int i;
    unsigned char bip8=(data[0]& 0x0f) ^ data[1] ^ data[2] ^ data[3];
    unsigned char bip4=((bip8 & 0xf0) >>4) ^ (bip8 & 0x0f);
    return bip4;
}

#include <stdio.h>
int main(int argc, char** argv) {

```

<sup>21</sup> Bits interleaved parity four bits wide

```
int i, input_char;
unsigned char data[4];
unsigned char bip4;
if (argc!=5) {
    fprintf(stderr,"Usage: ChkSum hexdata0 hexdata1 hexdata2
hexdata3\n");
    fprintf(stderr,"    Example:Usage: ChkSum 0x0d 0x0d 0x0d 0x0d\n");
    exit(1);
}
for (i=1; i<5; i++) {
    sscanf(argv[i],"%x",&input_char);
    data[i-1]=(unsigned char) input_char;
}
bip4=calcBIP4(data);
printf("Packet prior to checksum %2.2x %2.2x %2.2x %2.2x\n", data[0],
data[1],data[2],data[3]);
data[0]|= (bip4<<4); /* Add in the BIP-4 checksum */
printf("Bip-4 checksum value is %x\n",bip4);
printf("Packet with checksum %2.2x %2.2x %2.2x %2.2x\n", data[0],
data[1],data[2],data[3]);
}
```

## 9 Command Interface (Application Layer)

### 9.1 Command Format

#### 9.1.1 In-Bound (Host to Module)

The command packets consist of a 4 byte packet of which the lower 28 bits are used. The 4 high order bits are redefined by the transport layer (where the packet checksum is added). The shaded area shows the bits to be replaced by the transport layer.

Inbound Byte 0							
31	30	29	28	27	26	25	24
0x0 (To be defined by transport layer)					0x0		RW (R=0, W=1)

Inbound Byte 1							
23	22	21	20	19	18	17	16
Register Number (0x00 – 0xff)							

Inbound Byte 2							
15	14	13	12	11	10	9	8
Data 15:8							

Inbound Byte 3							
7	6	5	4	3	2	1	0
Data 7:0							

#### 9.1.2 Out-Bound (Module to Host)

The response packet consists of a 4 byte packet of which the lower 26 bits are used. The 6 high order bits contain a checksum and two flags which are redefined by the transport layer. The shaded area shows the bits to be replaced by the transport layer.

Outbound Byte 0							
31	30	29	28	27	26	25	24
0x0 (To be defined by transport layer)						Status	

Outbound Byte 1							
23	22	21	20	19	18	17	16
Register Number (0x00 – 0xff)							

Outbound Byte 2							
15	14	13	12	11	10	9	8
Data 15:8							

Outbound Byte 3							
7	6	5	4	3	2	1	0
Data 7:0							

The status field (bits 25:24) take on one of the 4 values in Table 9.1-1.

Table 9.1-1: Packet Status Flags

Bits 25:24 Value	Status Field
0x00	OK flag, Normal return status
0x01	XE flag, (execution error)
0x02	AEA flag, (Automatic extended addressing result being returned or ready to write)
0x03	CP flag, Command not complete, pending

Bits 25:24=0x00, OK flag, Normal. No execution errors and not using AEA mode for returning result.

Bits 25:24=0x01, XE flag (Execution Error) signifies that the previous command failed to execute properly. (Bits 25:24) not equal 0x01 signifies that the previous command completed successfully or is pending.

Bits 25:24=0x02, AEA flag, (automatic extended addressing) mode, indicates that the register (for which a read or write operation has been given) requires a multi-byte sequence<sup>22</sup>. The unsigned value is returned in bytes 2 and 3 and represents the number of bytes in the multi-byte response.

Bits 25:24=0x03, CP flag, Command pending (command not complete), indicates that the command will take longer than the maximum timeout specified for this device type.<sup>23</sup> In this case the module returns a response within the timeout period and continues to execute the requested operation. The host can poll the module's status register (0x00) through the communication's interface to determine if the operation has completed.

If the CP flag is set, the out-bound byte 3 will be 0x00 and out-bound byte 2 will have one of eight bits set (bits 15:8) showing which bit the pending operation has been assigned. Note that this bit mapping is identical to the bits 15:8 in the response of the NOP (x000) command.

Note that a write to an AEA register is always an AEA operation and may also be a pending operation. In this case, the module returns the AEA flag (0x02) in the status field and assigns a pending operation ID in the "Data 15:8" in the of the outbound response packet.

---

<sup>22</sup> In the case where a write was done to a register that supports AEA, outbound bytes 2 and 3 are ignored. The write command will need to be repeated this time addressing the AEA-EAR register instead.

<sup>23</sup> Device types/classes are specific implementations of tunable devices.

## 9.2 Register Summary

Table 9.2-1: Table of Registers (Commands)

Command	Register Name	Read / Write	AEA	Non-volatile (NV)	Description
<b>General Module Commands</b>					
0x00	NOP	R/W			Provide a way to read a pending response as from an interrupt, to determine if there is pending operation, and/or determine the specific error condition for a failed command.
0x01	DevTyp	R	AEA		Returns device type (tunable laser source, filter, modulator, etc) as a null terminated string.
0x02	MFGR	R	AEA		Returns manufacturer as a null terminated string in AEA mode (vendor specific format)
0x03	Model	R	AEA		Returns a model null terminated string in AEA mode (vendor specific format)
0x04	SerNo	R	AEA		Returns the serial number as null terminated string in AEA mode
0x05	MFGDate	R	AEA		Returns the mfg date as a null terminated string.
0x06	Release	R	AEA		Returns a manufacturer specific firmware release as a null terminated string in AEA mode
0x07	RelBack	R	AEA		Returns manufacturer specific firmware backwards compatibility as a null terminated string
0x08	GenCfg	RW			General module configuration
0x09	AEA-EAC	R			Automatic extended address configuration register
0x0A	AEA-EA	R			Automatic extended address (16 bits)
0x0B	AEA-EAR	RW			Location accessed "thru" AEA-EA and AEA-EAC
0x0C	Reserved				
0x0D	IOCap	RW		NV	Physical interface specific information (such as data rate, etc.)
0x0E	EAC	RW			Extended address configuration register - auto incr/decr flag on read and on write and additional address bits
0x0F	EA	RW			Extended address (16 bits)
0x10	EAR	RW			Location accessed "thru" EA and EAC
0x13 <sup>24</sup>	LstResp	R			Returns last response
0x14	DLConfig	RW			Download configuration register
0x15	DLStatus	R			Download status register
0x17 – 0x1F	Reserved	--	--		

<sup>24</sup> This command is deprecated. It may be available in some ITLA implementations.

Module Status Commands					
0x20	StatusF	RW			Contains reset status, optical faults and alarms, and enable status.
0x21	StatusW	RW			Contains reset status, warning optical faults and alarms, and enable status.
0x22	FPowTh	RW		NV	Returns/Sets the threshold for the output power FATAL condition encoded as $\pm\text{dB} \times 100$
0x23	WPowTh	RW		NV	Returns/Sets the threshold for the power warning encoded as $\pm\text{dB} \times 100$
0x24	FFreqTh	RW		NV	Returns/Sets the threshold for the frequency FATAL condition encoded as $\pm\text{GHz} \times 10$
0x25	WFreqTh	RW		NV	Returns/Sets the threshold for the frequency error warning encoded as $\pm\text{GHz} \times 10$
0x26	FThermTh	RW		NV	Returns/Sets the threshold for thermal deviations ( $> \pm^\circ\text{C} \times 100$ ) at which FATAL is asserted.
0x27	WThermTh	RW		NV	Returns/Sets the threshold for thermal deviations ( $> \pm^\circ\text{C} \times 100$ ) at which a warning is asserted.
0x28	SRQT	RW		NV	Indicates which bits in the Fatal & Warning status registers, 0x20-0x21, cause a SRQ condition and asserts the SRQ* line.
0x29	FatalT	RW		NV	Indicates which bits in the Fatal & Warning status register, 0x20-0x21, assert a FATAL condition
0x2A	ALMT	RW		NV	Indicates which bits in the status registers, 0x20, 0x21, cause an alarm condition. (Default behavior asserted whether laser is LOCKED on frequency.
0x2B – 0x2F	Reserved				
Module Optical Commands					
0x30	Channel	RW		NV	Setting valid channel causes a tuning operation to occur.
0x31	PWR	RW		NV	Sets the optical power set point as encoded as $\text{dBm} \times 100$
0x32	ResEna	RW			Reset/Enable - Enable output, hard and soft reset
0x33	MCB	RW		NV	Various module configurations
0x34	GRID	RW		NV	Allows the grid spacing to be set for channel numbering.
0x35	FCF1	RW		NV	Allows the first channel's frequency to be defined for channel numbering. (THz)
0x36	FCF2	RW		NV	Allows the first channel's frequency to be defined for channel numbering. ( $\text{GHz} \times 10$ )
0x37 – 0x3F	Reserved				Reserved for OIF configuration registers
0x40	LF1	R			Returns channel's frequency as THz
0x41	LF2	R			Returns channel's frequency as $\text{GHz} \times 10$
0x42	OOP	R			Returns the optical power encoded as $\text{dBm} \times 100$
0x43	CTemp	R			Returns the current temperature (monitored by the temperature alarm) encoded as $^\circ\text{C} \times 100$ .
0x44 – 0x4E	Reserved				Reserved for OIF status registers



Module Capabilities					
0x4F	FTFR	R			Returns min/max fine tune frequency range (MHz)
0x50	OPSL	R			Returns the min possible optical power setting
0x51	OPSH	R			Returns the max possible optical power setting
0x52	LFL1	R			Laser's first frequency (THz)
0x53	LFL2	R			Laser's first frequency (GHz*10)
0x54	LFH1	R			Laser's last frequency (THz)
0x55	LFH2	R			Laser's last frequency (GHz*10)
0x56	LGrid	R			Laser's minimum supported grid spacing (GHz*10)
MSA Commands					
0x57	Currents	R	AEA		Return module specific currents
0x58	Temps	R	AEA		Return module specific temperatures
0x59	DitherE	RW		NV	Digital dither enable
0x5A	DitherR	RW		NV	Digital dither rate
0x5B	DitherF	RW		NV	Digital dither frequency modulation
0x5C	DitherA	RW		NV	Digital dither amplitude modulation.
0x5D	TBTFLL	RW		NV	Sets the lower boundary for a warning on base of the butterfly temperature
0x5E	TBTFH	RW		NV	Sets the upper boundary for a warning on base of the butterfly temperature
0x5F	FAgeTh	RW		NV	Specifies the maximum end of life (EOL) percent aging at which fatal condition for the vendor specific error is asserted
0x60	WAgeTh	RW		NV	Specifies the maximum end of life (EOL) percent aging at which warning condition for the vendor specific error is asserted
0x61	Age	R			Returns the laser's age as a percentage
0x62	FTF	RW			Fine tune frequency adjustment of laser output.
0x63- 0x7F	Reserved				
Manufacturer Specific					
0x80-0xFE	Manufacturer Specific				

### 9.3 Command Description Format

The commands are described using 5 sections (note the shaded boxes in the table represent fields that are not applicable):

- 1) **Purpose** – Describes the basic purpose of the command.
- 2) **Synopsis** – Tabular format summarizing the command behavior and arguments
- 3) **Returns** – Tabular format summarizing the possible returns for successful and error conditions.
  - Status field (register 0x00)
  - Error condition field (0x00)
  - Data value (16 bit)
  - Effect on module
  - Execution time
  - Pending operation
- 4) **Detailed Description** – Describes the detailed behavior of the command
- 5) **Data Value Description** – Describes the data value for the command.

**6.3.1 NOP/Status (NOP 0x00) [RW]**

**Purpose** 1  
The NOP register provides a way access the module status returning pending operation status and the current value of the error field. This register may be read upon receiving an execution error for an immediately preceding command. It can also be polled to determine the status of pending operations.

**Synopsis** 2

Register Name	Register Number	Read / Write	Data Type Read or Written	Response Generated	Can Be Pending?	Volatile? Access?	Default Contents
NOP	0x00	R	Unsigned short	<5 ms	No	Volatile	Bits 15:8: 0x00 (pending bits) Bits 7:4: 0x0 (reserved) Bits 3:0: 0x0 (error field)
		W	Unsigned short	<5 ms	No	Not locked	

**Returns** 3

	Data Value Returned In Response Upon			
	Successful Read	Successful Write	Error on Read	Error on Write
Status Field Returned:	OK	OK	XE	XE
Error Condition Field:	OK	OK	CIP, CIL, EXF, or VSE	RNW, CIP, CIL, EXF, or VSE
Data Value:	Pending command status (bits 15:8) and error condition field (bits 3:0)	Same as was sent	0x0000	0x0000
Impact on Module	None, by definition	None, by definition	Error field set	Error field set
Execution Time:	<5ms	<5ms	<5ms	<5ms
Pending Operation:	Never	Never		

**Detailed Description** 4  
A write to the NOP register is allowed but the contents are not loaded with the data value from the write command.

**Data Value Description** 5

15	14	13	12	11	10	9	8	7	6	5	4	3	2	1	0	
Pending Operation Status											00		Error Field			

**Synopsis:**

Register Name	Register Number	Read / Write	Data Type Read or Written	Response Generated	Can Be Pending?	Volatile?	Default Contents
NOP	0x00	R	Unsigned short	See §10.2	No		Bits 15:8: 0x00 (pending bits) Bit 7:5: 0x0 (reserved) Bit 4: MRDY (0x0) Bits 3:0: 0x0 (error field)
		W	Unsigned short	See §10.2	No		

The **Synopsis** section describes the following:

Every command will show two lines; one for read and one for write. In the case of a read, the data value type is shown for the response packet. For a write, the data value type is shown as the operand of the command. (Note the shaded boxes in the table represent fields that are not applicable):

- 1) The “**Response Generated**” column indicates the maximum interval of time from when the command is acknowledged by the module until the module will generate a response. The transmission time of the response is dependent on the physical interface data rate and characteristics. See §7.2-Communication Interface.
- 2) The “**Can Be Pending**” column indicates if the command is allowed not to finish in the “Response Generated” time interval.

- 3) The “**Volatile**” column, if contains *non-volatile*, indicates that the default value loaded during power up or hard reset is loaded from non-volatile memory<sup>25</sup>. The defaults may be configured and stored using the GenCfg:SDC operation. See §9.4.9-General Module Configuration (GenCfg 0x08) [RW].
- 4) Where relevant, the “**Default Contents**” column indicates what the default contents would be for a freshly booted or reset module. Note that registers marked non-volatile have defaults values set by the GenCfg:SDC operation.

The **Returns** section describes the following for successful and failed read and write operations.

- 1) **Status Field Returned:** The value in the status field (bits 25:24) in the out-bound response (module to host).
- 2) **Error Condition Field:** The possible values contained in the NOP (0x00) commands error field because of the command’s execution or failure to execute.
- 3) **Data Value:** A description of the data value contained in the modules response.
- 4) **Effect on Module:** Indicates the resultant state of the module after requested operation has terminated.
- 5) **Execution Time:**The maximum time for the command to complete execution. Note this is different than the generation of a response described in the previous table.
- 6) **Pending Operation:** Indicates whether a successful command can return before the command has completed execution.

	Data Value Returned in Response Upon			
	Successful Read	Successful Write	Error on Read	Error on Write
<b>Status Field Returned:</b>	OK	OK	XE	XE
<b>Error Condition Field:</b>	OK	OK	CIP, CII, EXF, or VSE	RNW, CIP, CII, EXF, or VSE
<b>Data Value:</b>	Pending command status (bits 15:8) and error condition field (bits 3:0)	Same as was sent	0x0000	0x0000
<b>Impact on Module</b>	None, by definition	None, by definition	Error field set	Error field set
<b>Execution Time:</b>	<5ms	<5ms	<5ms	<5ms
<b>Pending Operation:</b>	Never	Never		

<sup>25</sup> The default configuration is typically user application specific and once configured is expected to be infrequently modified.

## 9.4 Generic Module Commands

### 9.4.1 NOP/Status (NOP 0x00) [RW]

#### Purpose

The NOP register provides a way to access the module's status, returning pending operation status, and the current value of the error field. This register may be read upon receiving an execution error for an immediately preceding command. It can also be polled to determine the status of pending operations.

#### Synopsis:

Register Name	Register Number	Read / Write	Data Type Read or Written	Response Generated	Can Be Pending?	Volatile?	Default Contents
NOP	0x00	R	Unsigned short	See §11.2	No		Bits15:8: 0x00 (pending bits) Bit 7:5: 0x0 (reserved) Bit 4: MRDY (0x0) Bits 3:0: 0x0 (error field)
		W	Unsigned short	See §11.2	No		

#### Returns

	Data Value Returned in Response Upon			
	Successful Read	Successful Write	Error on Read	Error on Write
<b>Status Field Returned:</b>	OK	OK	XE	XE
<b>Error Condition Field:</b>	OK	OK	EXF, or VSE	EXF, or VSE
<b>Data Value:</b>	Pending command status (bits 15:8), Bit 4, and error condition field (bits 3:0)	Same as was sent	0x0000	0x0000
<b>Effect on Module</b>	None, by definition	None, by definition	Error field set	Error field set
<b>Execution Time:</b>	See §11.2	See §11.2	See §11.2	See §11.2
<b>Pending Operation:</b>	Never	Never		

#### Detailed Description

A write to the NOP register is allowed but the contents are not loaded with the data value from the write command. The NOP command is guaranteed to succeed at all times except possibly during catastrophic failure of the module.

#### Data Value Description

15	14	13	12	11	10	9	8	7	6	5	4	3	2	1	0
Pending Operation Status								0x0		MRDY	Error Field				

#### Bits 15:8 – Pending Operation Flags

A series of eight flag bits indicating which operations, if any, are still pending. Each operation that becomes pending is assigned one of these four bit positions. The module can be periodically polled (by reading the NOP register) to determine which operations have completed. A value of 0x0 indicates that there are no currently pending operations.

Bit 7:5– Always 0x00 (Reserved)

Bit 4 – MRDY - Module Ready<sup>26</sup>

When “1” indicates that the module is ready for its output to be enabled

When “0” indicates that the module is not ready for its output to be enabled.

Bits 3:0 – Error field – Error condition for last completed command

<sup>26</sup> De-asserted during module warm up time (see §11.3-Module Warm Up Time) or if an invalid configuration detected. Asserted when module is ready to enable output and carry traffic.

A read of the NOP register will return the error condition from the last completed command before setting it to 0x00 to reflect the status of the current command (which is reading the NOP register).

Value (Bits 3:0)	Symbol	Meaning
0x00	OK	Ok, no errors
0x01	RNI	The addressed register is not implemented
0x02	RNW	Register not write-able; register cannot be written (read only)
0x03	RVE	Register value range error; writing register contents causes value range error; contents unchanged
0x04	CIP	Command ignored due to pending operation
0x05	CII	Command ignored while module is initializing, warming up, or contains an invalid configuration.
0x06	ERE	Extended address range error (address invalid)
0x07	ERO	Extended address is read only
0x08	EXF	Execution general failure
0x09	CIE	Command ignored while module's optical output is enabled (carrying traffic)
0x0A	IVC	Invalid configuration, command ignored
0x0B-0x0E	--	Reserved for future expansion
0x0F	VSE	Vendor specific error (see vendor specific documentation for more information)

The device type register is provided such that a host can distinguish between different types of tunable devices.

#### 9.4.2 Device Type (DevTyp 0x01) [R]

##### Purpose:

DevTyp returns the module's device type. For all tunable lasers covered by this MSA, the module will return the null terminated string "CW ITLA\0" (eight bytes including the terminating null character) indirectly through the AEA mechanism. The device type register is provided such that a host can distinguish between different types of tunable devices.

##### Synopsis:

Register Name	Register Number	Read / Write	Data Type Read or Written	Response Generated	Can Be Pending?	Volatile?	Default Contents
DevTyp	0x01	R	AEA (string)	See §11.2	No		0x0008 → "CW ITLA\0"
		W					

##### Returns

	Data Value Returned in Response Upon			
	Successful Read	Successful Write	Error on Read	Error on Write
Status Field Returned:	OK		XE	
Error Condition Field:	OK		CIP, CII, EXF, or VSE	
Data Value:	0x0008 → "CW ITLA\0"		0x0000	
Effect on Module	AEA registers configured to reference string		Error field set	
Execution Time:	See §11.2		See §11.2	
Pending Operation:	Never			

##### Detailed Description

A write to the DevTyp register results in an execution error.

### Data Value Description

DevTyp returns the length of ASCII string. Note that in this case, the null terminated string "CW ITLA\0" contains eight bytes including the null terminating byte.

### Example Usage

#	Command (Host to Module)			Response (Module to Host)		
	Operation	Register	Data Bytes (15:0)	Status	Register	Data Bytes (15:0)
1	Read	0x01 (DevTyp)	0x0000	0x02 (AEA-flag)	0x01 DevTyp	0x0008 (# bytes in string)
Note: When the Read is completed, registers (0x09, and 0x0A) are configured to point to proper field.						
2	Read	0x0B (AEA-EAR)	0x0000	0x00	0x0B (AEA-EAR)	0x4357 ("CW")
3	Read	0x0B (AEA-EAR)	0x0000	0x00	0x0B (AEA-EAR)	0x2049 (" I")
4	Read	0x0B (AEA-EAR)	0x0000	0x00	0x0B (AEA-EAR)	0x544C ("TL")
5	Read	0x0B (AEA-EAR)	0x0000	0x00	0x0B (AEA-EAR)	0x4100 ("A\0")
6	Read	0x0B (AEA-EAR)	0x0000	0x01 (XE-flag)	0x0B (AEA-EAR)	0x0000
Note: Query the NOP register to determine cause of execution error.						
7	Read	0x00 (NOP)	0x0000	0x00	0x00 (NOP)	0x0006 (ERE flag)

### 9.4.3 Manufacturer (MFGR 0x02) [R]

#### Purpose:

MFGR returns the module's manufacturers ID null terminated string indirectly through the AEA mechanism.

#### Synopsis:

Register Name	Register Number	Read / Write	Data Type Read or Written	Response Generated	Can Be Pending?	Volatile?	Default Contents
MFGR	0x02	R	AEA (string)	See §9.5.7	No		0x00xx → Manufacturer
		W					

#### Returns

	Data Value Returned in Response Upon			
	Successful Read	Successful Write	Error on Read	Error on Write
<b>Status Field Returned:</b>	OK		XE	
<b>Error Condition Field:</b>	OK		CIP, CII, EXF, or VSE	
<b>Data Value:</b>	0x00xx → Manufacturer		0x0000	
<b>Effect on Module</b>	AEA registers configured to reference string		Error field set	
<b>Execution Time:</b>	See §9.5.7		See §9.5.7	
<b>Pending Operation:</b>	Never			

#### Detailed Description

A write to the MFGR register results in an execution error.

#### Data Value Description

MFGR returns the length of a null terminated printable ASCII string. (Maximum 80 bytes)

### 9.4.4 Model (Model 0x03) [R]

#### Purpose:

Model returns the module's model designation string indirectly through the AEA mechanism. The null terminated string containing the module's model designation is

placed into a field of not more than 80 bytes in size. The model string is defined by the manufacturer

Synopsis:

Register Name	Register Number	Read / Write	Data Type Read or Written	Response Generated	Can Be Pending?	Volatile?	Default Contents
Model	0x03	R	AEA (string)	See §9.5.7	No		0x00xx → Model
		W					

Returns

	Data Value Returned in Response Upon			
	Successful Read	Successful Write	Error on Read	Error on Write
<b>Status Field Returned:</b>	OK		XE	
<b>Error Condition Field:</b>	OK		CIP, CII, EXF, or VSE	
<b>Data Value:</b>	0x00xx → Model		0x0000	
<b>Effect on Module</b>	AEA registers configured to reference string		Error field set	
<b>Execution Time:</b>	See §11.2		See §11.2	
<b>Pending Operation:</b>	Never			

Detailed Description

A write to the Model register results in an execution error.

Data Value Description

Model returns the length of a null terminated printable ASCII string. (Maximum 80 bytes)

### 9.4.5 Serial Number (SerNo 0x04) [R]

Purpose:

SerNo returns the module's serial number string indirectly through the AEA mechanism. The null terminated string containing the module's serial number is placed into a field of not more than 80 bytes in size. The serial number string is defined by the manufacturer.

Synopsis:

Register Name	Register Number	Read / Write	Data Type Read or Written	Response Generated	Can Be Pending?	Volatile?	Default Contents
SerNo	0x04	R	AEA (string)	See §9.5.7	No		0x00xx → SerNo
		W					

Returns

	Data Value Returned in Response Upon			
	Successful Read	Successful Write	Error on Read	Error on Write
<b>Status Field Returned:</b>	OK		XE	
<b>Error Condition Field:</b>	OK		CIP, CII, EXF, or VSE	
<b>Data Value:</b>	0x00xx → SerNo string		0x0000	
<b>Effect on Module</b>	AEA registers configured to reference string		Error field set	
<b>Execution Time:</b>	See §11.2		See §11.2	
<b>Pending Operation:</b>	Never			

Detailed Description

A write to the SerNo register results in an execution error.

### Data Value Description

SerNo returns the length of a null terminated printable ASCII string. (Maximum 80 bytes)

### 9.4.6 Manufacturing Date (MFGDate0x05) [R]

#### Purpose:

MFGDate returns the manufacturing date string of the module indirectly through the AEA mechanism. The null terminated string containing the date string is contained in a field size of 12 bytes.

#### Synopsis:

Register Name	Register Number	Read / Write	Data Type Read or Written	Response Generated	Can Be Pending?	Volatile?	Default Contents
MFGDate	0x05	R	AEA (string)	See §11.2	No		0x000C → Date
		W					

### Returns

	Data Value Returned in Response Upon			
	Successful Read	Successful Write	Error on Read	Error on Write
<b>Status Field Returned:</b>	OK		XE	
<b>Error Condition Field:</b>	OK		CIP, CII, EXF, or VSE	
<b>Data Value:</b>	0x000C → Date "DD-MON-YYYY\0"		0x0000	
<b>Effect on Module</b>	AEA registers configured to reference string		Error field set	
<b>Execution Time:</b>	See §11.2		See §11.2	
<b>Pending Operation:</b>	Never			

### Detailed Description

A write to the MFGDate register results in an execution error.

### Data Value Description

The MFGDate register returns the date of manufacture as a null terminated ASCII string (12 characters) formatted as "DD-MON-YYYY". *DD* is a 2 character field with leading zeros indicating the day of the month, *MON* is 3 character representation of the month (JAN,FEB,MAR,APR,MAY,JUN,JUL,AUG,SEP,OCT,NOV,DEC), and *YYYY* is the 4 digit year.

Example: "04-APR-2001"



### 9.4.7 Release (Release 0x06) [R]

#### Purpose:

Release returns the release string of the module indirectly through the AEA mechanism. The null terminated string containing the module release information is placed into a field of not more than 80 bytes in size. Note that a module may have one or more firmware and/or hardware revisions to track. The release field also encodes the application space identifier.

#### Synopsis:

Register Name	Register Number	Read / Write	Data Type Read or Written	Response Generated	Can Be Pending?	Volatile?	Default Contents
Release	0x06	R	AEA (string)	See §11.2	No		0x00xx → Module release
		W					

#### Returns

	Data Value Returned in Response Upon			
	Successful Read	Successful Write	Error on Read	Error on Write
<b>Status Field Returned:</b>	OK		XE	
<b>Error Condition Field:</b>	OK		CIP, CII, EXF, or VSE	
<b>Data Value:</b>	0x00xx → Module release		0x0000	
<b>Effect on Module</b>	AEA registers configured to reference string		Error field set	
<b>Execution Time:</b>	See §11.2		See §11.2	
<b>Pending Operation:</b>	Never			

#### Detailed Description

A write to the Release register results in an execution error. The module release string must contain at least protocol version and either a firmware or a hardware version.

### Data Value Description

Release returns the length of a null terminated printable ASCII string. (Maximum 80 bytes)

The release string consists of one or more concatenated release fields with a “:” used as the delimiter. A release field is white space delimited and consists of an identifier followed by a release version consisting of 3 base 10 numeric fields formatted as X.Y.Z. The application space identifier are defined in §11.1 - Optical Characteristics.

Format: “<Identifier<sub>1</sub>> <space> <X<sub>1</sub>.Y<sub>1</sub>.Z<sub>1</sub>> : <Identifier<sub>2</sub>> <space> <X<sub>2</sub>.Y<sub>2</sub>.Z<sub>2</sub>> ...”

Identifier	Description	Field	Values	Description
PV	Protocol version <sup>27</sup>	X	0:255	Major release - Change in fit, form, or function
HW	Hardware release	Y	0:255	Minor release - Improvements but no change in fit, form, or function
FW	Firmware release	Z	0:255	Patch Level
AS	Application Space			
<others>	Manufacturer specific			

The release fields are guaranteed to follow the following relationship.

- $X_{NEW} > X_{OLD}$
- $Y_{NEW} > Y_{OLD}$
- $Z_{NEW}$  and  $Z_{OLD}$  are not necessarily sequential and shall not be compared.

#### Example:

For example a module showing a firmware revision and a hardware revision would return a string like: “PV:2.0.0:FW 1.0.1:HW 3.2.1:AS A1”.

<sup>27</sup> The protocol version references the protocol document (this document) and indicates which version the module conforms.

### 9.4.8 Release Backwards Compatibility (RelBack 0x07) [R]

#### Purpose:

RelBack returns the release backwards compatibility string of the module indirectly through the AEA mechanism. The null terminated string containing the earliest release string which is fully backwards compatible with the current module. The string is contained in a field of not more than 80 bytes in size. Note that a module may have one or more firmware and/or hardware revisions to track as described in the Release (0x06) register.

#### Synopsis:

Register Name	Register Number	Read / Write	Data Type Read or Written	Response Generated	Can Be Pending?	Volatile?	Default Contents
RelBack	0x07	R	AEA (string)	See §11.2	No		0x00xx → Release
		W					

#### Returns

	Data Value Returned in Response Upon			
	Successful Read	Successful Write	Error on Read	Error on Write
<b>Status Field Returned:</b>	OK		XE	
<b>Error Condition Field:</b>	OK		CIP, CII, EXF, or VSE	
<b>Data Value:</b>	0x00xx → Release		0x0000	
<b>Effect on Module</b>	AEA registers configured to reference string		Error field set	
<b>Execution Time:</b>	See §11.2		See §11.2	
<b>Pending Operation:</b>	Never			

#### Detailed Description

A write to the RelBack register results in an execution error.

#### Data Value Description

RelBack returns the length of a null terminated printable ASCII string. (Maximum 80 bytes)

The release string consists of one or more concatenated release fields with a “:” used as the delimiter. A release field is white space delimited and consists of an identifier followed by a release version consisting of 3 base 10 numeric fields formatted as X.Y.Z.

Format: “<Identifier<sub>1</sub>> <space> <X<sub>1</sub>.Y<sub>1</sub>.Z<sub>1</sub>> : <Identifier<sub>2</sub>> <space> <X<sub>2</sub>.Y<sub>2</sub>.Z<sub>2</sub>> ...”

Identifier	Description	Field	Values	Description
HW	Hardware release	X	0:255	Major release - Change in fit, form, or function
FW	Firmware release	Y	0:255	Minor release - Improvements but no change in fit, form, or function
<others>	Manufacturer specific	Z	0:255	Patch Level – Not part of a normal release scheme

The release fields are guaranteed to follow the following relationship.

- $X_{NEW} > X_{OLD}$
- $Y_{NEW} > Y_{OLD}$
- $Z_{NEW}$  and  $Z_{OLD}$  are not necessarily sequential and shall not be compared to determine whether  $Z_{NEW}$  or  $Z_{OLD}$  is newer.

Example:

For example a module showing a firmware revision and a hardware revision might return a string: “PV:1.0.1:FW 1.0.1:HW 3.2.1” and might return a RelBack string: “PV:1.0.1:FW 1.0.0:HW 3.2.1”. This indicates that the current FW is backwards compatible with drivers written for FW 1.0.0 and that the hardware and protocol versions are the same.

### 9.4.9 General Module Configuration (GenCfg 0x08) [RW]

Purpose

GenCfg defines the general module configuration for the generic tunable device. For the tunable laser, the register is used to save the power on/reset module configuration defaults.

Synopsis:

Register Name	Register Number	Read / Write	Data Type Read or Written	Response Generated	Can Be Pending?	Volatile?	Default Contents
GenCfg	0x08	R	Unsigned short	See §11.2	No		0x0000
		W	Unsigned short	See §11.2	Yes		

Returns

	Data Value Returned in Response Upon			
	Successful Read	Successful Write	Error on Read	Error on Write
<b>Status Field Returned:</b>	OK	OK	XE	XE
<b>Error Condition Field:</b>	OK	OK	CIP, CII, EXF, or VSE	RNW, RVE, CIP, CII, EXF, CIE, or VSE
<b>Data Value:</b>	0x0000	Same as sent or pending ID	0x0000	0x0000
<b>Effect on Module</b>	None	Store registers marked <i>non-volatile</i> in non-volatile memory	Error field set	Error field set
<b>Execution Time:</b>	See §11.2	See §11.2	See §11.2	See §11.2
<b>Pending Operation:</b>	Never	Yes		

Detailed Description

Reading GenCfg always returns 0x0. Writing to GenCfg is only allowed when laser is not carrying traffic (optical output disabled)<sup>28</sup>.

The self clearing SDC (Store Default Configuration) flag is used to initiate a transfer of all registers marked non-volatile to non-volatile memory. The values are restored on power up or module reset.

Data Value Description

15	14	13	12	11	10	9	8	7	6	5	4	3	2	1	0
SDC		0x0000													

Bit 15: SDC (Store default configuration)

Read: Always returns zero.

Write:

“1”: Save all non-volatile module configuration values in non-volatile memory. This bit is self clearing. Upon power on or hard reset, the module

<sup>28</sup> Some module configuration changes may cause a traffic interrupting event. Therefore, configuration changes (writes to GenCfg) are only allowed when the optical output is disabled.

loads these configuration settings.<sup>29</sup> There may be other parameters which need to be saved as well such as the RUNV<sup>30</sup> state.  
“0”: Default = 0. No action taken on write.

#### 9.4.10 IO Capabilities (IOCap 0x0D) [RW]

##### Purpose

The IOCap register returns or sets the I/O interface capabilities<sup>31</sup>.

##### Synopsis:

Register Name	Register Number	Read / Write	Data Type Read or Written	Response Generated	Can Be Pending?	Volatile?	Default Contents
IOCap	0x0D	R	Unsigned short	See §11.2	No	Non-volatile	See §7.2
		W	Unsigned short	See §11.2	No		

##### Returns

	Data Value Returned in Response Upon			
	Successful Read	Successful Write	Error on Read	Error on Write
<b>Status Field Returned:</b>	OK	OK	XE	XE
<b>Error Condition Field:</b>	OK	OK	CIP, CII, EXF, or VSE	RNW, RVE, CIP, CII, EXF, VSE, or CIE
<b>Data Value:</b>	See §7.2	Same as was sent	0x0000	0x0000
<b>Effect on Module</b>	None	Alter physical interface characteristics	Error field set	Error field set
<b>Execution Time:</b>	See §11.2	See §11.2	See §11.2	See §11.2
<b>Pending Operation:</b>	Never	Never		

##### Detailed Description

The register returns to its default when hardware reset is asserted or when module is powered on.

When an interface speed is reconfigured, the response packet for the IOCap command is returned to the host. The interface speed is then changed to the requested speed and then the communication's interface is ready for a new command.

Changes to the module configuration are performed while the laser is not carrying traffic.

The IOCap configuration can be saved as module reset/power on defaults.

##### Data Value Description

See §7.2 Communication Interface for detailed information on the register fields and default values.

#### 9.4.11 Extended Addressing Mode Registers (0x09-0x0B, 0x0E-0x10) [RW]

##### Purpose

The predefined register set provides two sets of three registers each that are utilized for extended addressing. The first set (0x09-0x0B) is normally pre-configured by the module

<sup>29</sup> Care must be taken such that power loss or hard reset during a SDC operation results in the previously saved configuration to be fully restored upon power up or completion of reset.

<sup>30</sup> The RUNV value is non-volatile which can be asserted by the DLConfig register (§9.4.13). The DLConfig register is volatile. However, the GenCfg:SDC must save the RUNV state as well as the other register contents marked non-volatile.

<sup>31</sup> The value of the IOCap register is saved in non-volatile memory.

when the host reads from or writes to a register that supports AEA (automatic extended addressing) mode. The second set is normally pre-configured for large transfers such as a firmware upload or download. Note that two sets of extended address registers is desirable in case an AEA register needs to be accessed during a lengthy upload or download.

#### Synopsis:

Register Name	Register Number	Read / Write	Data Type Read or Written	Response Generated	Can Be Pending?	Volatile?	Default Contents
AEA-EAC	0x09	R	Unsigned short	See §11.2	No		0x0000
		W	Unsigned short	See §11.2	Yes		
AEA-EA	0x0A	R	Unsigned short	See §11.2	No		0x0000
		W					
AEA-EAR	0x0B	R	Defined by target field format	See §11.2	No		No Default Required
		W		See §11.2	Yes	--	
EAC	0x0E	R	Unsigned short	See §11.2	No		0x0000
		W	Unsigned short	See §11.2	Yes		
EA	0x0F	R	Unsigned short	See §11.2	No		0x0000
		W	Unsigned short	See §11.2	No		
EAR	0x10	R	Defined by target field format	See §11.2	No		No Default Required
		W		See §11.2	Yes	--	

#### Returns

	Data Value Returned in Response Upon			
	Successful Read	Successful Write	Error on Read	Error on Write
<b>Status Field Returned:</b>	OK	OK	XE	XE
<b>Error Condition Field:</b>	OK	OK	CIP, CII, ERE, EXF, or VSE	RNW, RVE, CIP, CII, ERE, ERO, EXF, or VSE
<b>Data Value:</b>	See definitions below	See definitions below	0x0000	0x0000
<b>Effect on Module</b>	EAC, EA- None EAR- EAC:EA incremented	EAC, EA- Configured EAR- Field written, EAC:EA incremented	Error field set Address unchanged	Error field set Address unchanged
<b>Execution Time:</b>	See §11.2	See §11.2	See §11.2	See §11.2
<b>Pending Operation:</b>	Never	Yes <sup>32</sup>		

#### Detailed Description

In order to access a location through the extended addressing interface, the EAC and EA registers must properly configured. This configuration occurs automatically when AEA designated registers are accessed or when the DLConfig process is initiated.

Read or write access of a register that supports AEA returns the number of bytes in the field. The access also configures the AEA-EAC and AEA-EA registers. Subsequent reads or writes on AEA-EAR transfers data sequentially from the physical or virtual memory location where the field is stored and may result in a pending operation. Note that although a write to a register that supports AEA access returns the maximum number of bytes to be written, but no data is actually written. The write command must be re-issued to the AEA-EAR register in order to complete the write.

<sup>32</sup> Note that writes to the AEA-EAR register or the EAR register may result a pending operation (CP flag) if a non-volatile memory “store” cycle takes longer than the 5ms execution time.

Operation on Register Which Support AEA	Data Value Sent	Status Flags	Effect on AEA	Data Value Returned
Read	0x0000	0x02 (AEA)	Configured	Number of bytes in the previously stored value.
Write	0x0000	0x00	NOT Configured	Maximum number of bytes that can be stored in the field.
	Number of bytes to be stored in the coming AEA transfer.	0x02 (AEA)	Configured	0xPP00 (Pending ID)

Reading or writing beyond the field boundaries will generate an execution error.

Operation on EAR	Data Value Sent		Effect on AEA	Data Value Returned
Read	0x0000	0x00	Address incremented after read	If successful, the data byte(s). If XE, result undefined.
Write	Data byte(s) to be written	0x00 or 0x03 (CP)	Address incremented after write	0x0000 or 0xPP00 (if pending)

An execution error on read or write does not increment the extended address register's contents.

A soft reset (ResEna 0x32) will abort extended address transfers (firmware uploads or AEA transfers). A low to high transition of MS\* will not abort extended address transfers but just clears the input buffers and may reset the baud rate.

#### Data Value Description

See the following sections.

##### 9.4.11.1 Extended Address Configuration (EAC 0x09 & 0x0E)

The first register, AEA-EAC (0x09) or EAC (0x0E), configures the extended addressing mode.

15	14	13	12	11	10	09	08	07	06	05	04	03	02	01	00
RAI		WAI		EAM			INCR		TBD	High order 6 address bits					

RAI: Read Auto Increment (Bits 15:14)

- 0x0 No address change on read
- 0x1 Address auto post increment by INCR on read
- 0x2 Address auto post decrement by INCR on read
- 0x3 Action not defined

WAI: Write Auto Increment (Bits 13:12)

- 0x0 No address change on write
- 0x1 Address auto post increment by INCR on write
- 0x2 Address auto post decrement by INCR on write
- 0x3 Action not defined

EAM: Extended Address Mode (Bits 11:9)

These three bits provide 8 possible address spaces. The default register space is defined with EAM=0x0. A firmware upgrade procedure would select the appropriate "code address

space”.

*Table 9.4-1 Extended Address Space Mode Selection (EAM)*

EAM	Address Space
0x0	Default register space (including 0x00 – 0xff)
0x1	Physical data space 1
0x2	Physical data space 2
0x3	Physical code space 1
0x4	Physical code space 2
0x5-0x7	Manufacturer specific

**INCR:** Increment register (Bits 8:7)

The auto increment and auto decrement operations modify the address by this unsigned value. For register space, this would typically be 1. If the physical space addressed by bytes, the best increment might more naturally be 2. If the configuration transfers 1 byte per read or write, only the low order byte is transferred and the high order byte is ignored.

**TBD:** Reserved (Bit 6)

**High order address bits:** (Bits 5:0)

The high order address bits are concatenated with the EA register forming a 22 bit physical or logical address or register number.

#### 9.4.11.2 Extended Address (EA 0x0A & 0x0F)

The second register, EA, contains the lower 16 address bits.

15	14	13	12	11	10	9	8	7	6	5	4	3	2	1	0
Extended Address (low order 16 bits)															

This register is set to the address value. Note with EAM=0x0, this register accesses the default register space. With EAM=0x0, extended addresses from 0x00 to 0xFF are equivalent to registers 0x00 to 0xFF.

#### 9.4.11.3 Extended Address Access Register (EAR 0x0B & 0x10)

A read on EAR causes the value referred to by EAC:EA to be returned. A write to EAR causes the location referred to by EAC:EA to be written, assuming the register is write-able. Note that on a write to EAR, the response is 0x0000 unless a pending operation must be asserted.

15	14	13	12	11	10	9	8	7	6	5	4	3	2	1	0
Contents of Extended Address															

#### 9.4.12 **Last Response (LstResp 0x13) [R]**

##### Purpose

LstResp can be used to resend the last packet. Note: The LstRsp bit in the Host to Module Packet (see Figure 8.1-1: In-Bound (Host to Module) Frame) is the preferred method for layer B to layer B error free communication. LstResp provides a layer C (application) level alternate.



Reading last response register forces the module to return all four bytes of the last response. This is useful if a checksum error was detected and the host wants to re-read the last response.

#### Synopsis:

Register Name	Register Number	Read / Write	Data Type Read or Written	Response Generated	Can Be Pending?	Volatile?	Default Contents
LstResp	0x13	R	Last Response	See §11.2	No		Last Response
		W					

#### Returns

	Data Value Returned in Response Upon			
	Successful Read	Successful Write	Error on Read	Error on Write
<b>Status Field Returned:</b>	OK		XE	
<b>Error Condition Field:</b>	OK		CIP, CII, EXF, or VSE	
<b>Data Value:</b>	Last Response		0x0000	
<b>Effect on Module</b>	None		Error field set	
<b>Execution Time:</b>	See §11.2		See §11.2	
<b>Pending Operation:</b>	Never			

#### Detailed Description

Returns the last sent packet. Typically used when last response contains a checksum error.

#### Data Value Description

Note that the entire out-bound packet is returned including all flag values.

#### Example Usage

#	Command (Host to Module)			Response (Module to Host)		
	Operation	Register	Data Bytes (15:0)	Status	Register	Data Bytes (15:0)
1	Read	0x00 (NOP)	0x0000	0x00 (Ok)	<b>0xFF</b> (garbled!!)	0x0000
	Note: Example showing garbled response, checksum indicate error in receipt of response.					
2	Read	0x13 (LstResp)	0x0000	0x00 (Ok)	0x00 (NOP)	0x0100
	Note: The module's last response is transmitted again and this time received correctly.					

### 9.4.13 Download Configuration (DLConfig 0x14) [RW]

#### Purpose

The DLConfig register configures a host to module download of code or data for reconfiguration purposes or configures a module to host upload of code or data to the host. A file transfer may occur at several locations such as vendor factory, customer site (on the bench), customer system (circuit down), or potentially a customer system (live circuit).

#### Synopsis:

Register Name	Register Number	Read / Write	Data Type Read or Written	Response Generated	Can Be Pending?	Volatile?	Default Contents
DLConfig	0x14	R	Unsigned short	See §11.2	No		0x0000   RUNV<<8
		W	Unsigned short	See §11.2	Yes		

#### Returns

	Data Value Returned in Response Upon			
	Successful Read	Successful Write	Error on Read	Error on Write
<b>Status Field Returned:</b>	OK	OK	XE	XE
<b>Error Condition Field:</b>	OK	OK	CIP, CII, EXF, or VSE	RNW, RVE, CIP, CII, EXF, CIE, or VSE
<b>Data Value:</b>	DL Configuration	Same as sent or pending ID	0x0000	0x0000
<b>Effect on Module</b>	None	Down Load configured, check initiated, or RUNV execution selected	Error field set	Error field set
<b>Execution Time:</b>	See §11.2	See §11.2	See §11.2	See §11.2
<b>Pending Operation:</b>	Never	May be pending		

#### Detailed Description

The following example describes the actions required to transfer a file from the host to the module and then have the module run that file.

*Table 9.4-2 Firmware Download Example*

Step	Host Sends	Module Responds
1	Write the DLConfig register indicating the type of transfer coming and asserting INIT_WRITE=1 and TYPE. Code might be boot code, run time code, FPGA code, CPLD code.	Module responds by initializing extended address registers (0x0E-0x0F) and may return a pending operation flag if pre-configuration will take longer than the allowed response time (§11.2).
2	Host writes to the extended address register (0x10) with the file data, 2 bytes at a time.	Module receives file data 2 bytes at a time and asserts a pending operation flag as necessary. Each out-bound packet response indicates if any errors have occurred.
3	Host writes DLConfig and asserts DONE=1.	Module completes transfer and performs any clean-up operations related to the write sequence. The module may respond with a pending operation flag.
4	Host writes DLConfig and asserts INIT_CHECK=1	The module performs the consistency check and sets the VALID bit accordingly in DLStatus. The module may respond with a pending operation flag.
5	Host reads DLStatus and checks for VALID=1	Modules responds with the DLStatus information
6	Host writes DLConfig with INIT_RUN=1 and asserts RUNV set to the same value as TYPE in step 1.	Module either (1) responds and is running the new requested code segment or (2) the module responds with a pending operation flag and begins the process of running the requested code segment.

*Table 9.4-3 Firmware Upload Example*

Step	Host Sends	Module Responds
1	Write the DLConfig register indicating the type of transfer coming and asserting INIT_READ=1 and TYPE. Code might be boot code, run time code, FPGA code, CPLD code.	Module responds by initializing extended address registers (0x0E-0x0F) and may return a pending operation flag if pre-configuration will take longer than the allowed response time (§11.2).
2	Host reads from the extended address register (0x10), 2 bytes at a time.	Module sends file data 2 bytes at a time. Each out-bound packet response indicates if any errors have occurred.

### Data Value Description

When the DLConfig register is read, the RUNV value returns the value for the firmware currently running in the module. This value is unchanged with a power down or reset. The other fields return the default values.

15	14	13	12	11	10	9	8
TYPE				RUNV			

7	6	5	4	3	2	1	0
Reserved (0x0)		INIT_RUN	INIT_CHECK	INIT_READ	DONE	ABRT	INIT_WRITE

#### INIT\_WRITE Bit 0

This bit informs the module to prepare for download and may result in a pending operation. The module should perform its necessary housekeeping to be ready for download. Pre-configures the extended address registers (0x0E-0x0F).

0 – Do not start download. (default)

1 – Prepare for download. (May result in a pending operation)

#### ABRT Bit 1

This bit informs the module to abort the transfer and may result in a pending operation.

0 – Do not abort transfer. (default)

1 – Abort the transfer. (May result in a pending operation)

#### DONE Bit 2

This bit informs the module that the transfer is complete and may result in a pending operation.

0 – Transfer is not done. (default)

1 – Transfer is done. (May result in a pending operation)

#### INIT\_READ Bit 3

This bit informs the module to prepare for upload and may result in a pending operation. Like INIT\_WRITE, this pre-configures the extended address registers (0x0E- 0x0F).

0 – Do not start upload. (default)

1 – Prepare for upload (May result in a pending operation)

**INIT\_CHECK Bit 4**

This bit, when set to “1”, instructs the module to check the segment specified in the TYPE field for consistency and may result in a pending operation. Upon completion, the DLStatus (0x015) register’s VALID bit is set to “1” or set to “0” to indicate if the segment is valid.

0 – Do not initiate consistency check. (default)

1 – Initiate consistency check (May result in a pending operation)

**INIT\_RUN Bit 5**

This bit, when set to “1”, informs the module to run the segment specified in the RUNV field. The module will transmit a response packet. The request may result in a pending operation if the time to begin execution of the requested code segment will take longer than the maximum time for the module to construct a response<sup>33</sup>. (See §11.2)

0 – Do not run code specified by RUNV. (default)

1 – Run code specified by RUNV (May result in a pending operation)

**RUNV – Bit 8-11**

Specifies version to run when written with a non-zero value and with INIT\_RUN=1. Returns the current version that is currently executing when read. The default setting is vendor specific. Vendors may not support all RUNV values. A RUNV value which contains a code segment with an invalid internal CRC check on that code segment will return an execution error (EXF).

TYPE Value	Code Type	Effect on Module
0x00	No change to value	None
0x01	Main Version 1	Non-Service interrupting
0x02	Main Version 2	Non-Service interrupting
0x03	Main Version A	Service Interrupting
0x04	Main Version B	Service Interrupting
0x05-0x08	Reserved	
0x09 – 0xFE	Vendor specific	
0xFF	Reserved	

<sup>33</sup> There may be a short period of time during the pending operation when it will not respond to commands from the host.

**TYPE Bit 12-15**

Type of code to Transfer (0x0 – default)

TYPE Value	Code Type	Effect on Module
0x0	No change to value	None
0x1	FW Version A1	Non-Service interrupting <sup>34</sup>
0x2	FW Version B1	
0x3	FW Version A2	Service Interrupting <sup>35</sup>
0x4	FW Version B2	
0x5-0x8	Reserved	
0x9 – 0xE	Vendor specific	
0xF	Reserved	

**9.4.14 Download Status (DLStatus 0x15) [R]**
**Purpose**

DLStatus provides information about the status or viability of a code segment.

**Synopsis:**

Register Name	Register Number	Read / Write	Data Type Read or Written	Response Generated	Can Be Pending?	Volatile?	Default Contents
DLStatus	0x08	R	Unsigned short	See §11.2	No		Defined upon write to DLConfig
		W					

**Returns**

	Data Value Returned in Response Upon			
	Successful Read	Successful Write	Error on Read	Error on Write
<b>Status Field Returned:</b>	OK		XE	
<b>Error Condition Field:</b>	OK		CIP, CII, EXF, or VSE	
<b>Data Value:</b>	Defined upon write to DLConfig		0x0000	
<b>Effect on Module</b>	None		Error field set	
<b>Execution Time:</b>	See §11.2		See §11.2	
<b>Pending Operation:</b>	Never			

**Detailed Description**

The register provides information on the polling sequence that should be used during the configured download (see §9.4.13) as well as the status of the download.

<sup>34</sup> The primary firmware is generally loaded and executed without interrupting traffic (A1, B1). However, there may be technologies for which the firmware download may be service interrupting and would be loaded in slots A2, B2.

<sup>35</sup> A DLConfig write to initiate a service interrupting download while the module's output is enabled is not allowed and an execution error is returned (CIE).

### Data Value Description

15	14	13	12	11	10	9	8	7	6	5	4	3	2	1	0
														IN_USE	VALID

#### VALID Bit 0

Indicates that the module has a valid code type at this location. Asserted after the DLConfig (0x14) "TYPE" field is written with a non-zero type field and with "INIT\_CHECK" equal to 1.

0 – Indicates that the module does not have a valid code type at this location.

1 – Indicates that the module does have a valid code type at this location.

#### IN\_USE Bit 1

Can be used to indicate that the code type specified in the DLConfig (0x14) "TYPE" field is currently in use.

0 – Indicates that segment is not currently in use

1 – Indicates that segment is currently in use

## 9.5 Module Status Commands

### 9.5.1 StatusF, StatusW (0x20, 0x21) [RW]

#### Purpose

The StatusF and StatusW commands return the tunable laser status upon a read and provide a way to clear status flags on a write. There are two status registers, one that primarily indicates FATAL conditions (0x20) and the other that primarily indicates WARNING conditions (0x21).

#### Synopsis:

Register Name	Register Number	Read / Write	Data Type Read or Written	Response Generated	Can Be Pending?	Volatile?	Default Contents
StatusF	0x20	R	Unsigned short	See §11.2	No		0x0000
		W	Typically 0x00FF	See §11.2	No	--	
StatusW	0x21	R	Unsigned short	See §11.2	No		0x0000
		W	Typically 0x00FF	See §11.2	No	--	

#### Returns

	Data Value Returned in Response Upon			
	Successful Read	Successful Write	Error on Read	Error on Write
<b>Status Field Returned:</b>	OK	OK	XE	XE
<b>Error Condition Field:</b>	OK	OK	CIP, CII, EXF, or VSE	CIP, CII, EXF, or VSE
<b>Data Value:</b>	Status value	Same as sent (0x00FF)	0x0000	0x0000
<b>Effect on Module</b>	None	Clear the corresponding flags where bit=1	Error field set	Error field set
<b>Execution Time:</b>	See §11.2	See §11.2	See §11.2	See §11.2
<b>Pending Operation:</b>	Never	Never		

### Detailed Description

The fatal and warning flags have both a latched representation and a non-latched representation. The latched versions of the flags remain set even if the transient condition expires. The fatal and warning flags are available.

Condition	FATAL Conditions		Warning Conditions	
	Latching	Non-Latching	Latching	Non-Latching
Thermal	F THERML	F THERM	W THERML	W THERM
Output Power	F PWRL	F PWR	W PWRL	W PWR
Frequency	F FREQL	F FREQ	W FREQL	W FREQ
Vendor Specific Fault	F VSFL	F VSF	W VSFL	W VSF

Fatal flags indicate a serious failure in the tunable laser typically result in optical output shutdown to avoid interference with other channels. Module behavior due to fatal conditions is specified in register MCB (0x33), bit SDF. Fatal conditions vary with laser technology but might be a result of one of the following:

- Gross loss of thermal control primarily impacting frequency and/or output power control of the module. An example would be an inability to determine frequency accurately due to loss of thermal control. The control set point is defined by the manufacturer and the control limits are specified in register FThermTh (0x26).
- Gross loss of optical output power control to within the required tolerance contained in the FPowTh (0x22) register.
- Gross loss of frequency control to within the required tolerance contained in the FFreqTh (x024) register.
- Laser aging has exceeded the fatal age threshold contained in register FAgeTh. Other vendor specific fatal conditions determined by technology choice can also be overloaded.

Warning flags indicate non-fatal conditions in the module and will not cause shutdown. Warning conditions may be precursors to eventual fatal failure. Warning conditions vary with laser technology. The following list contains only some of the possible conditions resulting in a warning. See manufacturer's documentation for a complete list.

- Thermal
  - Module's base of butterfly temperature exceeds control limits set by TBTFH and TBTFH (0x5D-5E)
  - Module's internal thermal control is marginal. Control limits set by WThermTh (0x27)
- Power – (Control limits set by WpowTh) (0x23)
- Frequency – (Control limits set by WfreqTh) (0x25)
- Other vendor specific warning conditions determined by technology choice such as:
  - Module aging exceeding warning threshold (WAgeTh (0x60)).
  - Control loop failure.

The latched flags are cleared by writing a "1" to the corresponding bit position. Typically, the latched bits are cleared by writing a 0x00FF to each register (0x20, 0x21). Clearing the latched bits will cause de-assertion of the corresponding conditions or hardware line (SRQ\*). If the event is still occurring, the corresponding latched bit will be set back to "1" triggering re-assertion of the corresponding condition.

### Data Value Description

0x20 Current Status (Fatal) – Read Only							
15	14	13	12	11	10	9	8
SRQ	ALM	FATAL	DIS	FVSF	FFREQ	FTHERM	FPWR

0x20 Latched Status (Fatal) – RW							
7	6	5	4	3	2	1	0
XEL	CEL	MRL	CRL	FVSFL	FFREQL	FTHERML	FPWRL

0x21 Current Status (Warning) – Read Only							
15	14	13	12	11	10	9	8
SRQ	ALM	FATAL	DIS	WVSF	WFREQ	WTherm	WPWR

0x21 Latched Status (Warning) – RW							
7	6	5	4	3	2	1	0
XEL	CEL	MRL	CRL	WVSFL	WFREQL	WTherML	WPWRL

The other status flags are defined as follows:

Condition	Latched Flag	Non-Latching Flag
SRQ* asserted	None	SRQ
ALM asserted	None	ALM
FATAL asserted	None	FATAL
DIS* asserted	None	DIS
Execution error asserted	XEL	XE flag in out-bound byte 0
Communications error asserted	CEL	CE flag in out-bound byte 0
Module Reset asserted	MRL	None
CR asserted	CRL	None

Bits 15:8 in the status registers are non-latching and indicate the current module condition. These bits cannot be cleared. Writing to these bits (0xFF00) does not cause an error.

Bits 7:0 are latching and indicate whether any of the conditions that have occurred since the last time the status registers were cleared. These bits can be cleared by writing a 0x00FF to the status registers.

Bit 15: SRQ – Service Request Bit (read –only) (default 0)

The SRQ bit is read only. It reflects the state of the module’s SRQ\* line. When the SRQ\* line is asserted (low or zero), this bit is set to 1. The SRQ\* line is fully configurable through the SRQ\* trigger register 0x28.

Bit 14: ALM – ALARM Flag bit (read-only) (default 0)

The ALM bit is read only. When the ALM condition is asserted, this bit is set to 1. The conditions which assert the ALM condition are fully configurable through the alarm trigger register (0x2A).

Bit 13: FATAL – FATAL alarm bit (read-only) (default 0)

The FATAL bit is read only. When the FATAL condition is asserted, this bit is set to 1. The conditions which set the FATAL condition are fully configurable through the fatal trigger register (0x29).

Bit 12: DIS – Module’s output is hardware disabled (read-only)

The module’s laser output disable bit is read only and represents the state of the hardware disable pin (DIS\*). When set to one, the module is “hardware” disabled. When the DIS\* pin is set to zero, the SENA bit is also cleared. Therefore when DIS\* is set to one, the module does not re-enable the output until the SENA is also set.



Any state change in DIS can cause SRQ\* to be asserted if the appropriate SRQ\* trigger is set.<sup>36</sup>

- 1: Module disabled (DIS\* line is low)
- 0: DIS\* line is high

Bit 11: FVSF, WVSF – Vendor Specific Fault (read-only) (default 0)

The FVSF bit (0x20) is set to 1 whenever a fatal vendor specific condition is asserted. The WVSF bit (0x21) is set to 1 whenever a warning vendor specific condition is asserted. If either of these bits is set, the vendor will have a register defined which contains vendor specific fault conditions. This bit is also asserted when laser aging thresholds are exceeded (See §9.8.5 Age Threshold (FAgeTh, WAgeTh 0x5F, 0x60) [RW]).

Bit 10: FFREQ & WFREQ – Frequency Fatal and Warning (read-only) (default 0)

The FFREQ bit (0x20) reports that the frequency deviation has exceeded the frequency fatal threshold (0x24) while WFREQ bit (0x21) reports that the frequency deviation has exceeded the frequency warning threshold (0x25).

When bit 10 is 1, it indicates that the frequency deviation threshold is being exceeded. When bit 10 is 0, the frequency deviation threshold is not being exceeded.

Bit 9: FTHERM & WThERM – Thermal Fatal and Warning (read-only) (default 0)

The FTHERM bit (0x20) reports that the thermal deviation has exceeded the thermal fatal threshold (0x26) while WThERM bit (0x21) reports that the thermal deviation has exceeded the thermal warning threshold (0x27).

When bit 9 is 1, it indicates that the thermal deviation threshold is being exceeded. When bit 9 is 0, the thermal deviation threshold is not being exceeded.

Bit 8: FPWR & WPWR – Power Fatal and Warning (read-only) (default 0)

The FPWR bit (0x20) reports that the power deviation has exceeded the power fatal threshold (0x22) while WPWR bit (0x21) reports that the power deviation has exceeded the power warning threshold (0x23).

When bit 8 is 1, it indicates that the power deviation threshold is being exceeded. When bit 8 is 0, the power deviation threshold is not being exceeded.

Bit 7: XEL – Flags an execution error.

A “1” indicates an exceptional condition. Note that execution errors could be generated by a command just given which failed to execute as well as a command that was currently executing (a pending operation that just complete). The default RS232 configuration only sets XEL when a pending operation fails. The XE bit remains set until cleared.

Bit 6: CEL – Flags a communication error.

A “1” indicates a communication error. The CE bit remains set until cleared.

Bit 5: MRL – Module Restarted (latched) (default 1 – by definition)

MRL can be read or set to zero. When it is “1”, it indicates that the module has been restarted either by power up, by hardware or software reset, or by a firmware mandated restart. Depending upon the implementation, this may indicate that the

---

<sup>36</sup> The operation ensures that a tuning operation only occurs under s/w control. The primary purpose of the DIS\* pin is to rapidly disable the laser output.

laser's output signal may be invalid. Note that the module can be reset through the communication interface by writing to register 0x32. The bit remains set until cleared.

Bit 4: CRL – Communication Reset (latched) (default 1 – by definition)  
CRL can be read or set to zero. When it is set, it indicates that the module has undergone a communication interface reset. The input buffers were cleared. This can also occur after a manufacturer specific timeout period has elapsed in the middle of a packet transfer.<sup>37</sup> The bit remains set until cleared.

Bits 3,2,1,0: FVSFL, FFREQL, FOTHERML, FPWRL, WVSFL, WFREQL, WOTHERML, WPWRL – Latched fatal and warning indicators (RW) (default 0)  
These flags are latched versions of bits 11-8 for the fatal and warning threshold deviations. These bit indicators can be cleared by writing a “1” to these bit positions.

When any of these bits is 1, it indicates that the corresponding deviation threshold has been exceeded at sometime in past (since the last clear) and may still be occurring.

When any of these bits are “0”, the corresponding deviation threshold has not occurred since the last clear.

### 9.5.2 Power Threshold (FPowTh, WPowTh 0x22, 0x23) [RW]

#### Purpose

FPowTh specifies the maximum power deviation  $\pm$ dB at which the fatal alarm is asserted.

WPowTh specifies the maximum power deviation  $\pm$ dB at which the warning alarm is asserted.

#### Synopsis:

Register Name	Register Number	Read / Write	Data Type Read or Written	Response Generated	Can Be Pending?	Volatile?	Default Contents
FPowTh	0x22	R	Unsigned short dB*100	See §11.2	No	Non-volatile	Manufacturer specific
		W		See §11.2	No		
WPowTh	0x23	R	Unsigned short dB*100	See §11.2	No	Non-volatile	Manufacturer specific
		W		See §11.2	No		

#### Returns

	Data Value Returned in Response Upon			
	Successful Read	Successful Write	Error on Read	Error on Write
Status Field Returned:	OK	OK	XE	XE
Error Condition Field:	OK	OK	CIP, CII, EXF, or VSE	RNW, RVE, CIP, CII, EXF, or VSE
Data Value:	dB*100	dB*100 (Same as sent)	0x0000	0x0000
Effect on Module	None	New tolerance takes effect	Error field set	Error field set
Execution Time:	See §11.2	See §11.2	See §11.2	See §11.2
Pending Operation:	Never	Never		

<sup>37</sup> Added reference to the capability of a communication interface timeout which would occur if a packet transfer didn't complete. The timeout would be manufacturer specific.

### Detailed Description

The value is stored in dB\*100 as an unsigned integer. Setting a value outside of the usable range causes an execution error. The default is manufacturer specific and can be modified when the module configuration is stored in non-volatile memory.

### Data Value Description

The value is stored in dB\*100 as an unsigned integer. The warning threshold (0x23) should typically be equal to or less than the value in register 0x22.

## 9.5.3 Frequency Threshold (FFreqTh, WFreqTh 0x24, 0x25) [RW]

### Purpose

FFreqTh specifies the maximum frequency deviation  $\pm$ GHz at which the fatal alarm is asserted.

WFreqTh specifies the maximum frequency deviation  $\pm$ GHz at which the warning alarm is asserted.

### Synopsis:

Register Name	Register Number	Read / Write	Data Type Read or Written	Response Generated	Can Be Pending?	Volatile	Default Contents
FFreqTh	0x24	R	Unsigned short $\pm$ GHz*10	See §11.2	No	Non-volatile	Application specific
		W		See §11.2	No		
WFreqTh	0x25	R	Unsigned short $\pm$ GHz*10	See §11.2	No	Non-volatile	Application specific
		W		See §11.2	No		

### Returns

	Data Value Returned in Response Upon			
	Successful Read	Successful Write	Error on Read	Error on Write
<b>Status Field Returned:</b>	OK	OK	XE	XE
<b>Error Condition Field:</b>	OK	OK	CIP, CII, EXF, or VSE	RNW, RVE, CIP, CII, EXF, or VSE
<b>Data Value:</b>	$\pm$ GHz*10	$\pm$ GHz*10 (Same as sent)	0x0000	0x0000
<b>Effect on Module</b>	None	New tolerance takes effect	Error field set	Error field set
<b>Execution Time:</b>	See §11.2	See §11.2	See §11.2	See §11.2
<b>Pending Operation:</b>	Never	Never		

### Detailed Description

The value is stored in GHz\*10 as an unsigned integer. Setting a value outside of the usable range causes the value to be set to the maximum allowed. The default is manufacturer specific and can be modified when the module configuration is stored in non-volatile memory.

### Data Value Description

The value is stored in GHz\*10 as an unsigned integer. The warning threshold (0x25) should typically be equal to or less than the value in register 0x24.

Setting a value outside of the usable range generates an execution error. The default is application specific.

### 9.5.4 Thermal Threshold (FThermTh, WThermTh 0x26, 0x27) [RW]

#### Purpose

FThermTh specifies the maximum thermal deviation  $\pm^{\circ}\text{C}$  at which the fatal alarm is asserted.

WThermTh specifies the maximum frequency deviation  $\pm^{\circ}\text{C}$  at which the warning alarm is asserted.

#### Synopsis:

Register Name	Register Number	Read / Write	Data Type Read or Written	Response Generated	Can Be Pending?	Volatile?	Default Contents
FThermTh	0x26	R	Unsigned short $\pm^{\circ}\text{C} \times 100$	See §11.2	No	Non-volatile	Manufacturer specific
		W		See §11.2	No		
WThermTh	0x27	R	Unsigned short $\pm^{\circ}\text{C} \times 100$	See §11.2	No	Non-volatile	Manufacturer specific
		W		See §11.2	No		

#### Returns

	Data Value Returned in Response Upon			
	Successful Read	Successful Write	Error on Read	Error on Write
<b>Status Field Returned:</b>	OK	OK	XE	XE
<b>Error Condition Field:</b>	OK	OK	CIP, CII, EXF, or VSE	RNW, RVE, CIP, CII, EXF, or VSE
<b>Data Value:</b>	$\pm^{\circ}\text{C} \times 100$	$\pm^{\circ}\text{C} \times 100$ (Same as sent)	0x0000	0x0000
<b>Effect on Module</b>	None	New tolerance takes effect	Error field set	Error field set
<b>Execution Time:</b>	See §11.2	See §11.2	See §11.2	See §11.2
<b>Pending Operation:</b>	Never	Never		

#### Detailed Description

The value is stored in  $^{\circ}\text{C} \times 100$  as an unsigned integer. Setting a value outside of the usable range causes the value to be set to the maximum allowed. The default is manufacturer specific and can be modified when the module configuration is stored in non-volatile memory.

#### Data Value Description

The value is stored in  $^{\circ}\text{C} \times 100$  as an unsigned integer. The warning threshold (0x27) should typically be equal to or less than the value in register 0x26.

Setting a value outside of the usable range generates an execution error. The default is application specific. The registers contain the maximum thermal deviation  $\pm^{\circ}\text{C} \times 100$  that is allowed before asserting a FATAL condition. The default is manufacturer specific.

### 9.5.5 SRQ\* Triggers (SRQT 0x28) [RW]

#### Purpose

The SRQT register identifies the corresponding bits in the status registers (StatusF, StatusW) for which the SRQ\* line is asserted.

#### Synopsis:

Register Name	Register Number	Read / Write	Data Type Read or Written	Response Generated	Can Be Pending?	Volatile?	Default Contents
SRQT	0x28	R	Unsigned short	See §11.2	No	Non-volatile	Suggested: 0x1FFF or 0x1FBF
		W		See §11.2	No		

#### Returns

	Data Value Returned in Response Upon			
	Successful Read	Successful Write	Error on Read	Error on Write
<b>Status Field Returned:</b>	OK	OK	XE	XE
<b>Error Condition Field:</b>	OK	OK	CIP, CII, EXF, or VSE	RNW, CIP, CII, EXF, or VSE
<b>Data Value:</b>	See bit assignments below	Same as sent	0x0000	0x0000
<b>Effect on Module</b>	None	New triggers take effect	Error field set	Error field set
<b>Execution Time:</b>	See §11.2	See §11.2	See §11.2	See §11.2
<b>Pending Operation:</b>	Never	Never		

#### Detailed Description

The SRQT register identifies the corresponding bits in the status registers (StatusF, StatusW) for which the SRQ\* line is asserted. The default is manufacturer specific and can be modified when the module configuration is stored in non-volatile memory.

The SRQ\* condition is not triggered for frequency, thermal control temperature, or power faults when the laser is not in a locked state. However, a case temperature condition would assert SRQ if WHERML or FTHERML is selected for in SRQT.

#### Data Value Description

A "1" bit signifies that the corresponding status register bit triggers the assertion of the SRQ\* line. A "0" signifies that the corresponding status register bit does not trigger the assertion of the SRQ\* line.

The layout of the SRQT register follows the same format as the status registers (StatusF, StatusW 0x20, 0x21).

15	14	13	12	11	10	9	8
			DIS	WVSFL	WFREQ	WHERML	WPWRL
0	0	0	1	1	1	1	1
7	6	5	4	3	2	1	0
XEL	CEL	MRL	CRL	FVSFL	FFREQ	FTHERML	FPWRL
1	0	1	1	1	1	1	1

When using RS232 communication, execution errors and communication errors for the immediate command are returned immediately in the module's response packet. However, pending operations can generate execution errors and should generate an SRQ\* through the XEL status flag.

The SRQ\* line can be de-asserted by either changing this register or by clearing the latched fault condition in the status registers (0x20, 0x21).

### 9.5.6 FATAL Triggers (FatalT 0x29) [RW]

#### Purpose

The FatalT register identifies the corresponding bits in the status registers (StatusF, StatusW) for which the FATAL condition is asserted.

#### Synopsis:

Register Name	Register Number	Read / Write	Data Type Read or Written	Response Generated	Can Be Pending?	Volatile?	Default Contents
FatalT	0x29	R	Unsigned short	See §11.2	No	Non-volatile	Suggested: 0x000F
		W		See §11.2	No		

#### Returns

	Data Value Returned in Response Upon			
	Successful Read	Successful Write	Error on Read	Error on Write
<b>Status Field Returned:</b>	OK	OK	XE	XE
<b>Error Condition Field:</b>	OK	OK	CIP, CII, EXF, or VSE	RNW, CIP, CII, EXF, or VSE
<b>Data Value:</b>	See bit assignments below	Same as sent	0x0000	0x0000
<b>Effect on Module</b>	None	New triggers take effect	Error field set	Error field set
<b>Execution Time:</b>	See §11.2	See §11.2	See §11.2	See §11.2
<b>Pending Operation:</b>	Never	Never		

#### Detailed Description

The FatalT register identifies the corresponding bits in the status registers (StatusF, StatusW) for which the FATAL condition is asserted. The default is manufacturer specific and can be modified when the module configuration is stored in non-volatile memory.

The FATAL condition is not triggered for frequency, thermal control temperature, or power faults when the laser is not in a locked state.

#### Data Value Description

A “1” bit signifies that the corresponding status register bit triggers the assertion of the FATAL condition. A “0” signifies that the corresponding status register bit does not trigger the assertion of the FATAL condition.

The layout of the FatalT register follows the same format as the status registers (StatusF, StatusW 0x20, 0x21). This register sets the bits for which the FATAL condition is asserted. It follows the similar format as the status register (0x20, 0x21).

15	14	13	12	11	10	9	8
				WVSFL	WFREQL	W THERML	WPWRL
0	0	0	0	0	0	0	0
7	6	5	4	3	2	1	0
		MRL		FVSFL	FFREQL	F THERML	FPWRL
0	0	0	0	1	1	1	1

The FATAL condition can be de-asserted by either changing this register or by clearing the latched fault condition in the status registers (0x20).

### 9.5.7 ALM Triggers (ALMT 0x2A) [RW]

#### Purpose

The ALMT register identifies the corresponding bits in the status registers (StatusF, StatusW) for which the ALM condition is asserted. The default setting enables the ALM status to signal “locked to channel”.

#### Synopsis:

Register Name	Register Number	Read / Write	Data Type Read or Written	Response Generated	Can Be Pending?	Volatile?	Default Contents
ALMT	0x2A	R	Unsigned short	See §11.2	No	Non-volatile	Suggested: 0x0D0D
		W		See §11.2	No		

#### Returns

	Data Value Returned in Response Upon			
	Successful Read	Successful Write	Error on Read	Error on Write
<b>Status Field Returned:</b>	OK	OK	XE	XE
<b>Error Condition Field:</b>	OK	OK	CIP, CII, EXF, or VSE	RNW, CIP, CII, EXF, or VSE
<b>Data Value:</b>	See bit assignments below	Same as sent	0x0000	0x0000
<b>Effect on Module</b>	None	New triggers take effect	Error field set	Error field set
<b>Execution Time:</b>	See §11.2	See §11.2	See §11.2	See §11.2
<b>Pending Operation:</b>	Never	Never		

#### Detailed Description

The ALMT register identifies the corresponding bits in the status registers (StatusF, StatusW) for which the ALM condition is asserted. The default is manufacturer specific and can be modified when the module configuration is stored in non-volatile memory.

The ALM status can function as a LOCKED indicator which gets asserted during tuning or output disable when the ADT (alarms during tuning) configuration is set in MCB (0x33).

#### Data Value Description

A “1” bit signifies that the corresponding status register bit triggers the assertion of the ALM condition. A “0” signifies that the corresponding status register bit does not trigger the assertion of the ALM condition.

The layout of the ALMT register follows the same format as the status registers (StatusF, StatusW 0x20, 0x21). This register sets the bits for which the ALM condition is asserted. It follows the similar format as the status register (0x20, 0x21).

15	14	13	12	11	10	9	8
				WVSF	WFREQ	W THERM	WPWR
0	0	0	0	1	1	0	1

7	6	5	4	3	2	1	0
				FVSF	FFREQ	F THERM	FPWR
0	0	0	0	1	1	0	1

A setting of 0x0700 which is useful (along with ADT in the Module configuration register (MCB 0x33) to cause the ALM status to function as a LOCKED indicator. ALM is then asserted during tuning or output disable. The ALM condition can be de-asserted by changing this register.

## 9.6 Module Optical Settings

### 9.6.1 Channel (Channel 0x30) [RW]

#### Purpose

Channel sets the module's channel.

#### Synopsis:

Register Name	Register Number	Read / Write	Data Type Read or Written	Response Generated	Can Be Pending?	Volatile?	Default Contents
Channel	0x30	R	Unsigned short	See §11.2	No	Non-volatile	Configured default with SENA=0
		W	Unsigned short	See §11.2	Yes		

#### Returns

	Data Value Returned in Response Upon			
	Successful Read	Successful Write	Error on Read	Error on Write
<b>Status Field Returned:</b>	OK	OK	XE	XE
<b>Error Condition Field:</b>	OK	OK	CIP, CII, EXF, or VSE	RNW, RVE, CIP, CII, EXF, or VSE
<b>Data Value:</b>	Unsigned short channel number	Same as sent or pending ID	0x0000	0x0000
<b>Effect on Module</b>	None	Begin tuning process	Error field set	Error field set
<b>Execution Time:</b>	See §11.2	See §11.2	See §11.2	See §11.2
<b>Pending Operation:</b>	Never	Typically for most technologies		

#### Detailed Description

The frequency for this channel is defined as:

$$\text{Freq (GHz)} = (\text{Channel} - 1) * \text{grid\_spacing} (0x34 / 10) + \text{Frequency\_of\_first\_channel} (0x35 * 1000, 0x36 / 10) + \text{FTF} (0x4F / 1000).$$

Assuming the module is hardware and software enabled, (DIS\*=1 and SENA=1), the module will disable its optical output and then re-enable its optical output tuned to the channel specified in the Channel register. If SENA=0 (and/or DIS\*=1), the channel setting is accepted but the optical output will not be enabled to the new setting until SENA=1 and DIS\*=1. Note that changing the DIS\* pin to high will not re-enable output. SENA must be set to "1" after the DIS\* pin is set high.

The output is disabled under the following conditions:

$$\text{Disabled} = ((\text{Fatal\_Status} \& \text{Fatal\_Trigger}) \&\& \text{SDF}) \parallel \sim\text{SENA} \parallel \sim\text{DIS}$$

Where:

Fatal\_Status is register (0x20)

Fatal\_Trigger is register (0x29)

SDF is a software enable for fatal alarm to control output [0x0002 & (MCB 0x33)]

SENA is a software control of the output [0x0008 & (ResEna 0x32)]

DIS is hardware control of the output. [0x1000 & (StatusF 0x20)].

An execution error (XE) resulting from the module's inability to successfully tune to the specified channel (Error = EXF) will leave the optical output off.

The tuning time is technology dependent. See §11.2 Timing Specification.



The default is manufacturer specific and can be modified when the module configuration is stored in non-volatile memory.

#### Data Value Description

Bits 15:0
16 bit unsigned channel number

A 16 bit unsigned integer representing the desired channel number. Increasing channel may be associated with increasing frequency or decreasing frequency depending upon the sign of the grid\_spacing (GRID 0x34) value.

Channel 0 is an undefined channel number. Writing this register with an invalid channel number will not change the register value and will generate an execution error. Writing a value outside of the channel range will generate an execution error. Note that execution errors other than EXF will leave channel unchanged.

#### Examples

Example 1 shows a configuration where the channel number is frequency in GHz less 180000. Example 2 shows a configuration using 50GHz channel numbers.

Parameter	Example 1		Example 2	
Grid Spacing	Grid (0x34)	1 GHz	Grid (0x34)	-50GHz
First Channel Frequency	FCF (0x35,36)	180000	FCF (0x35,36)	196300
Frequency	Channel=1	180.000 THz (~1655nm)	Channel =1	196.300 THz (~1527nm)
	Channel=65535	245.534 THz (~1221nm)	Channel=200	186.350 THz (~1609nm)
	Channel=X	180000 + X-1	Channel=X	196300 - 50*(X-1)

The following example shows a channel map configuration followed by a tuning event.

#	Command (Host to Module)			Response (Module to Host)		
	Operation	Register	Data Bytes (15:0)	Status	Register	Data Bytes (15:0)
Set up the channel mapping (Grid spacing and first channel frequency)						
1	Write	0x34 (Grid)	0x0032 (50 <sub>10</sub> )	0x00 (Ok-flag)	0x30 (Grid)	0x0032
2	Write	0x35 (FCF1) (first channel frequency)	0x00C4 (196 <sub>10</sub> )	0x00 (Ok-flag)	0x35 (FCF1)	0x00C4
3	Write	0x36 (FCF2)	0x012C (3000 <sub>10</sub> )	0x00 (Ok-flag)	0x36 (FCF2)	0x012C
Set the channel number causing a tuning operation. For this technology, the channel returns with the command in progress assign it pending operation #1 (bit 4). (Assuming that both s/w enable and h/w enable are already in enabled state)						
3	Write	0x30 (Channel)	0x0001	0x03 (CP-flag)	0x30 (Channel)	0x0100
Host polls module waiting for pending operation to complete.						
4	Read	0x00 (NOP)	0x0000	0x00 (Ok-flag)	0x00 (NOP)	0x0100
5	Read	0x00 (NOP)	0x0000	0x00 (Ok-flag)	0x00 (NOP)	0x0100
6	Read	0x00 (NOP)	0x0000	0x00 (Ok-flag)	0x00 (NOP)	0x0000
Operation complete when its pending operation bit (bit 8 in this case) returns to zero. Note that a tuning failure will assert SRQ* by default if the tuning operation as pending.						

Note that the default module configuration is to assert an SRQ\* for an execution error resulting from a pending operation. The following example shows a tuning failure event.

#	Command (Host to Module)			Response (Module to Host)		
	Operation	Register	Data Bytes (15:0)	Status	Register	Data Bytes (15:0)
	Set the channel number causing a tuning operation. For this technology, the channel returns with the command in progress assign it pending operation #3 (bit 6).					
1	Write	0x30 (Channel)	0x0001	0x03 (CP-flag)	0x30 (Channel)	0x0400
	Host polls module waiting for pending operation to complete.					
2	Read	0x00 (NOP)	0x0000	0x00 (Ok-flag)	0x00 (NOP)	0x0400
3	Read	0x00 (NOP)	0x0000	0x00 (Ok-flag)	0x00 (NOP)	0x0400
	Execution error occurs and module asserts SRQ* line for the failed pending operation					
4	Read	0x00 (NOP)	0x0000	0x00 (Ok-flag)	0x00 (NOP)	0x0008
	Pending operation bit 4 is now zero signaling the termination of the pending operation. The error field contains 0x8 (EXF – execution failure).					

### 9.6.2 Optical Power Set Point (PWR 0x31) [RW]

#### Purpose

PWR sets the optical output power set point in dBm\*100 as a signed integer. The desired power is not necessarily achieved when the command returns.

#### Synopsis:

Register Name	Register Number	Read / Write	Data Type Read or Written	Response Generated	Can Be Pending?	Volatile?	Default Contents
PWR	0x31	R	Signed short int (dBm*100)	See §11.2	No	Non-volatile	Manufacturer specific
		W		See §11.2	Yes		

#### Returns

	Data Value Returned in Response Upon			
	Successful Read	Successful Write	Error on Read	Error on Write
<b>Status Field Returned:</b>	OK	OK	XE	XE
<b>Error Condition Field:</b>	OK	OK	CIP, CII, EXF, or VSE	RNW, RVE, CIP, CII, EXF, or VSE
<b>Data Value:</b>	dBm*100	Same as sent	0x0000	0x0000
<b>Effect on Module</b>	None	Power set point changed	Error field set	Error field set
<b>Execution Time:</b>	See §11.2	See §11.2	See §11.2	See §11.2
<b>Pending Operation:</b>	Never	Can be		

#### Detailed Description

Typically, the optical power set point is configured prior to the set channel command (Channel 0x30) command is sent. The default is manufacturer specific and can be modified when the module configuration is stored in non-volatile memory.

Setting the optical power set point while locked on channel will cause the output power to change within technology limits and is guaranteed to be traffic non-interrupting). If the requested power change is out of range, an execution error is generated. If the requested power is within the technology limits but requires a traffic interrupting event<sup>38</sup> to achieve the new power setting, the command should return a CIE error. This prevents the host from accidentally disrupting traffic during a power adjustment. An output power alarm maybe asserted (WPWR (StatusW)) if the difference in power from old to new setting exceeds the

<sup>38</sup> A traffic interrupting event is one in which the channel becomes unlocked. Power variation within the operating range during adjustment is not considered traffic interrupting for this case. For example, a change from 7dBm to 13 dBm while frequency remains intact (less than or equal to frequency accuracy) is allowed.

power thresholds. The host can determine when the power change has completed by either monitoring the pending status (NOP 0x00) or, if the ADT (alarms during tuning) bit (MCB 0x33) is set, by monitoring the WPWR (StatusW) bit or ALM bit if the appropriate ALMT mask setting is set.

Note: this power is an approximate value since it will typically be measured internally and the correlation between the fiber coupled optical output power and internally measured power will vary. The default is manufacturer specific.

#### Data Value Description

The optical output power set point is encoded as a signed integer in dBm\*100. Therefore, a value of 0x3E8 (1000<sub>10</sub>) represents 10dBm.

### 9.6.3 Reset/Enable (ResEna 0x32) [RW]

#### Purpose

Writing to the Reset/Enable register can initiate a soft reset or a hard reset of the module or can software enable/disable the optical output.

#### Synopsis:

Register Name	Register Number	Read / Write	Data Type Read or Written	Response Generated	Can Be Pending?	Volatile?	Default Contents
ResEna	0x32	R	Unsigned short	See §11.2	No		0x0000
		W	Unsigned short	See §11.2	(Yes)		

#### Returns

	Data Value Returned in Response Upon			
	Successful Read	Successful Write	Error on Read	Error on Write
<b>Status Field Returned:</b>		OK		XE
<b>Error Condition Field:</b>		OK		RNW, RVE, CIP, CII, EXF, or VSE
<b>Data Value:</b>		Same as sent or pending ID		0x0000
<b>Effect on Module</b>		Perform specified reset operation		Error field set
<b>Execution Time:</b>		<200ms		See §11.2
<b>Pending Operation:</b>		Setting SENA=1 can result in a pending operation		

### Detailed Description

The Reset/Enable register provides way through software to reset the module or software enable or disable the optical output.

Writing SENA=1 causes the optical output to be enabled to the channel set in (0x30)<sup>39</sup>. Writing SENA=0 causes the optical output to be disabled. Depending upon laser technology, writing SENA=1 may result in a pending operation if a channel tune is required.

Either a soft reset (SR=1) or a hardware module reset (MR=1) can be selected. In the event that both are selected, the hardware module reset takes precedence.

The soft reset resets the communication's interface and is traffic non-interrupting. Extended address registers are reset.

The hardware reset is typically traffic interrupting since it will reset control loops as well. The host can poll the communication's interface waiting for a response packet indicating that the interface is ready to communicate. Note that a response is returned to acknowledge the reset request before the reset is started.

### Data Value Description

15	14	13	12	11	10	9	8	7	6	5	4	3	2	1	0
												SENA		SR	MR

Bit 0: MR: Module Reset (write-able) (default 0x00)

When set to "1", the module undergoes a "hard" reset. The impact to the optical signal is undefined. This bit is self clearing.

Bit 1: SR: Soft Reset<sup>40</sup> (write-able) (default 0x00)

When set to "1", the module undergoes a "soft reset". The intention is that the module will undergo a soft reset without impacting the traffic carrying capacity of the optical signal. This bit is self-clearing.

Bit 3: SENA – Software enable of output (default 0)

A "1" indicates that the software is allowing the output to be enabled.

A "0" indicates that the software had disabled the output or DIS\* had been "0".

This pin is used in conjunction with the DIS\* pin. In order for a signal to appear at the optical output, both the DIS\*=high and the SENA=1.

The output is disabled under the following conditions:

Disable = ((Fatal\_Status & Fatal\_Trigger) && SDF) || ~SENA || ~DIS

Where:

Fatal\_Status is register (0x20)

Fatal\_Trigger is register (0x29)

SDF is a software enable for fatal alarm to control output [0x0004 & (MCB 0x33)]

SENA is a software control of the output [0x0008 & (ResEna 0x32)]

DIS\* is hardware control of the output. [0x1000 & (StatusF 0x20)].

Note that setting SENA=1 can result in a pending operation.

<sup>39</sup> Of course, this assumes that no other factors are present which force the output to be disabled (a fatal condition with SDF=1 (see §9.6.4 Module Configuration) or DIS\*=0).

<sup>40</sup> The soft reset will include the communication's interface reset. The communication's interface reset can also be accomplished through de-asserting the MS\* pin.

### 9.6.4 Module Configuration Behavior (MCB 0x33) [RW]

#### Purpose

The MCB register provides a way to configure a number of module behaviors.

#### Synopsis:

Register Name	Register Number	Read / Write	Data Type Read or Written	Response Generated	Can Be Pending?	Volatile?	Default Contents
MCB	0x33	R	Unsigned short	See §11.2	No	Non-volatile	0x0002
		W	Unsigned short	See §11.2	No		

#### Returns

	Data Value Returned in Response Upon			
	Successful Read	Successful Write	Error on Read	Error on Write
<b>Status Field Returned:</b>	OK	OK	XE	XE
<b>Error Condition Field:</b>	OK	OK	CIP, CII, EXF, or VSE	RNW, RVE, CIP, CII, EXF, CIE, or VSE
<b>Data Value:</b>	Unsigned short	Same as sent	0x0000	0x0000
<b>Effect on Module</b>	None	Configured	Error field set	Error field set
<b>Execution Time:</b>	See §11.2	<200ms	See §11.2	See §11.2
<b>Pending Operation:</b>	Never	Never		

#### Detailed Description

The ADT (Alarm During Tuning) configuration supports alarms to be asserted during a channel tune. As soon as the tuning operation is successful, the alarm is deasserted.

The SDF (Shut Down on Fatal) configuration supports the need to disable the optical output should any of the selected fatal conditions occur (FATAL condition is asserted).

The default can be modified when the module configuration is stored in non-volatile memory.

#### Data Value Description

15	14	13	12	11	10	9	8	7	6	5	4	3	2	1	0
0x000													SDF	ADT	0

Bit 1: ADT – Alarm during tuning or disable (warning status flags)

The default (0x1) allows alarm conditions during tuning or disable. If set to 0x1, ALM is asserted during tuning or when the output is disabled. This default causes the ALM status to function as a LOCKED to channel indicator, even during tuning. Note that ALMT (0x2A) should be set to at least 0x0700 for this behavior.

Bit 2: SDF – Shut down optical output on fatal condition.

A fatal condition occurs when the FATAL is asserted.

The default (0x0) does not cause the optical output to shutdown on fatal alarm.

Fatal conditions are somewhat technology specific but would be signaled by any of the bits 10:8 in register 0x20 (StatusF) being set.

### 9.6.5 Grid Spacing (Grid 0x34) [RW]

#### Purpose

Grid sets the module's grid spacing for the channel to frequency mapping.

#### Synopsis:

Register Name	Register Number	Read / Write	Data Type Read or Written	Response Generated	Can Be Pending?	Volatile?	Default Contents
Grid	0x34	R	Signed short (GHz*10)	See §11.2	No	Non-volatile	Manufacturer specific
		W		See §11.2	No		

#### Returns

	Data Value Returned in Response Upon			
	Successful Read	Successful Write	Error on Read	Error on Write
<b>Status Field Returned:</b>	OK	OK	XE	XE
<b>Error Condition Field:</b>	OK	OK	CIP, CII, EXF, or VSE	RNW, CIP, CII, EXF, CIE, RVE, or VSE
<b>Data Value:</b>	Signed short (GHz*10)	Same as sent	0x0000	0x0000
<b>Effect on Module</b>	None	Set grid spacing – no immediate impact on frequency	Error field set	Error field set
<b>Execution Time:</b>	See §11.2	See §11.2	See §11.2	See §11.2
<b>Pending Operation:</b>	Never	Never		

#### Detailed Description

The frequency for a channel is defined as:

$$\text{Freq (GHz)} = (\text{Channel} - 1) * \text{grid\_spacing} (0x34 / 10) + \text{Frequency\_of\_first\_channel} (0x35 * 1000, 0x36 / 10) + \text{FTF} (0x4F / 1000).$$

This value can only be changed when the output is disabled. Changing it while the optical output is enabled generates an execution error. This register is only used during tuning to set the output frequency register. Any grid spacing can be set but may result in many unreachable channel frequencies.

The default is manufacturer specific and can be modified when the module configuration is stored in non-volatile memory.

#### Data Value Description

The register is a signed integer and allows for grid spacings as high as  $\pm 3.28$  THz and as low as 0.1 GHz.

### 9.6.6 First Channel's Frequency (FCF1, FCF2 0x35 – 0x36) [RW]

#### Purpose

The FCF1 and FCF2 registers provide a way to configure the frequency of channel 1.

#### Synopsis:

Register Name	Register Number	Read / Write	Data Type Read or Written	Response Generated	Can Be Pending?	Volatile?	Default Contents
FCF1	0x35	R	Unsigned short (THz)	See §11.2	No	Non-volatile	Manufacturer specific
		W		See §11.2	No		
FCF2	0x36	R	Unsigned short (GHz*10)	See §11.2	No	Non-volatile	Manufacturer specific
		W		See §11.2	No		

#### Returns

	Data Value Returned in Response Upon			
	Successful Read	Successful Write	Error on Read	Error on Write
<b>Status Field Returned:</b>	OK	OK	XE	XE
<b>Error Condition Field:</b>	OK	OK	CIP, CII, EXF, or VSE	RNW, CIP, CII, EXF, VSE, RVE, or CIE
<b>Data Value:</b>	Unsigned short	Same as sent	0x0000	0x0000
<b>Effect on Module</b>	None	Configured	Error field set	Error field set
<b>Execution Time:</b>	See §11.2	See §11.2	See §11.2	See §11.2
<b>Pending Operation:</b>	Never	Never		

#### Detailed Description

This value can only be changed when the output is disabled. Changing it while the output is enabled will generate an execution error. The register contents are unsigned integers. The order in which FCF1 and FCF2 are written is not significant. Both should be defined properly before either enabling the optical output or saving the module's configuration as the default configuration (See §9.4.9 General Module Configuration (GenCfG 0x08) [RW]).

#### Data Value Description

The frequency in GHz is equal to  $(0x35 \cdot 10^3 + 0x36 \cdot 10^{-1})$ .

For instance, 194.175 THz would be represented by

Register	Hex Value	Decimal Value
0x35	0x00C2	194
0x36	0x06D6	1750

Frequency (GHz) is then  $194 \cdot 10^3 + 1750 \cdot 10^{-1}$  or 194175.0 GHz. The default value for this register will be manufacturer specific.

### 9.6.7 Laser Frequency (LF1, LF2 0x40 – 0x41) [R]

#### Purpose

The LF1 and LF2 registers provide a way to read the frequency of the current channel.

#### Synopsis:

Register Name	Register Number	Read / Write	Data Type Read or Written	Response Generated	Can Be Pending?	Volatile?	Default Contents
LF1	0x40	R	Unsigned short (THz)	See §11.2	No		Manufacturer specific
		W					
LF2	0x41	R	Unsigned short (GHz*10)	See §11.2	No		Manufacturer specific
		W					

#### Returns

	Data Value Returned in Response Upon			
	Successful Read	Successful Write	Error on Read	Error on Write
<b>Status Field Returned:</b>	OK		XE	
<b>Error Condition Field:</b>	OK		CIP, CII, EXF, or VSE	
<b>Data Value:</b>	Unsigned short		0x0000	
<b>Effect on Module</b>	None		Error field set	
<b>Execution Time:</b>	See §11.2		See §11.2	
<b>Pending Operation:</b>	Never			

#### Detailed Description

The frequency for a channel is computed as follows:

$$\text{Freq (GHz)} = (\text{Channel} - 1) * \text{grid\_spacing} (0x34 / 10) + \text{Frequency\_of\_first\_channel} (0x35 * 1000, 0x36 / 10) + \text{FTF} (0x4F / 1000).$$

The laser may or not have its optical output enabled when the register is read.

#### Data Value Description

The frequency in GHz is equal to  $(0x40 * 10^3 + 0x41 * 10^{-1})$ . Default value consistent with Grid spacing register and channel number.

For instance, 194.175 THz would be represented by

Register	Hex Value	Decimal Value
0x40	0x00C2	194
0x41	0x06D6	1750

Frequency (GHz) is then  $194 * 10^3 + 1750 * 10^{-1}$



### 9.6.8 Optical Output Power (OOP 0x42) [R]

#### Purpose

The OOP register provides a way to read the external optical power estimate.

#### Synopsis:

Register Name	Register Number	Read / Write	Data Type Read or Written	Response Generated	Can Be Pending?	Volatile?	Default Contents
OOP	0x42	R	Signed short (dBm*100)	See §11.2	No		Manufacturer specific
		W					

#### Returns

	Data Value Returned in Response Upon			
	Successful Read	Successful Write	Error on Read	Error on Write
Status Field Returned:	OK		XE	
Error Condition Field:	OK		CIP, CII, EXF, or VSE	
Data Value:	Signed short (dBm*100)		0x0000	
Effect on Module	None		Error field set	
Execution Time:	See §11.2		See §11.2	
Pending Operation:	Never			

#### Detailed Description

The optical module's output power. This value is in dBm\*100 and is a signed integer. In units with internal power monitors, this is of course, an approximate value.

#### Data Value Description

The optical output power is stored as a signed integer as dBm\*100.

### 9.6.9 Current Temperature (CTemp 0x43) [R]

#### Purpose

The CTemp register provides a way to read the current temperature of the primary control temperature.

#### Synopsis:

Register Name	Register Number	Read / Write	Data Type Read or Written	Response Generated	Can Be Pending?	Volatile?	Default Contents
CTemp	0x43	R	Signed short (°C*100)	See §11.2	No		Manufacturer specific
		W					

#### Returns

	Data Value Returned in Response Upon			
	Successful Read	Successful Write	Error on Read	Error on Write
Status Field Returned:	OK		XE	
Error Condition Field:	OK		CIP, CII, EXF, or VSE	
Data Value:	Signed short (°C*100)		0x0000	
Effect on Module	None		Error field set	
Execution Time:	See §11.2		See §11.2	
Pending Operation:	Never			

### Detailed Description

The current temperature reported as an integer encoded in 0.01°C. The temperature set point is vendor specific. This register displays the temperature value used to determine if a fatal thermal condition has occurred.

### Data Value Description

The temperature is represented as signed short integer with units of °C\*100.

## 9.7 Module's Capabilities

### 9.7.1 Fine Tune Frequency Range (FTF 0x4F) [R]

#### Purpose

The FTFR register provides the ability to query the minimum and maximum fine tune frequency range capabilities of the module.

#### Synopsis:

Register Name	Register Number	Read / Write	Data Type Read or Written	Response Generated	Can Be Pending?	Volatile?	Default Contents
FTFR (max/min)	0x4F	R	Unsigned short (MHz)	See §11.2	No		Manufacturer specific
		W					

#### Returns

	Data Value Returned in Response Upon			
	Successful Read	Successful Write	Error on Read	Error on Write
<b>Status Field Returned:</b>	OK		XE	
<b>Error Condition Field:</b>	OK		CIP, CII, EXF, or VSE	
<b>Data Value:</b>	Unsigned short (MHz)		0x0000	
<b>Effect on Module</b>	None		Error field set	
<b>Execution Time:</b>	See §11.2		See §11.2	
<b>Pending Operation:</b>	Never			

### Detailed Description

This register reports the minimum and maximum fine tune frequency setting which is possible for the module. This single value covers the min/max range symmetrically about 0. For example, an FTFR of 5000 indicates that the module is capable of having a fine tune frequency adjustment of +/- 5GHz about the tuned frequency.

### Data Value Description

The value is represented as MHz, unsigned short integer. Note: This value cannot exceed 32767 as the FTF register is bound to a signed short input.

## 9.7.2 Optical Power Min/Max Set Points (OPSL, OPSH 0x50 – 0x51) [R]

### Purpose

The OPSL and OPSH registers provide a way to read the minimum and maximum optical power capabilities of the module.

### Synopsis:

Register Name	Register Number	Read / Write	Data Type Read or Written	Response Generated	Can Be Pending?	Volatile?	Default Contents
OPSL (Min)	0x50	R	Signed short (dBm*100)	See §11.2	No		Manufacturer specific
		W					
OPSH (Max)	0x51	R	Signed short (dBm*100)	See §11.2	No		Manufacturer specific
		W					

### Returns

	Data Value Returned in Response Upon			
	Successful Read	Successful Write	Error on Read	Error on Write
<b>Status Field Returned:</b>	OK		XE	
<b>Error Condition Field:</b>	OK		CIP, CII, EXF, or VSE	
<b>Data Value:</b>	Signed short (dBm*100)		0x0000	
<b>Effect on Module</b>	None		Error field set	
Execution Time:	See §11.2		See §11.2	
<b>Pending Operation:</b>	Never			

### Detailed Description

These registers report the minimum optical power setting which is possible (OPSL) and the maximum setting which is possible (OPSH) for the module.

### Data Value Description

The value is represented as dBm\*100, signed short integer.

### 9.7.3 Laser's First/Last Frequency (LFL1/2, LFH1/2 0x52-0x55) [R]

#### Purpose

Returns the min and max frequency that the module supports.

#### Synopsis:

Register Name	Register Number	Read / Write	Data Type Read or Written	Response Generated	Can Be Pending?	Volatile?	Default Contents
LFL1 (Min)	0x52	R	Unsigned short (THz)	See §11.2	No		Manufacturer specific
		W					
LFL2 (Min)	0x53	R	Unsigned short (GHz*10)	See §11.2	No		Manufacturer specific
		W					
LFH1 (Min)	0x54	R	Unsigned short (THz)	See §11.2	No		Manufacturer specific
		W					
LFH2 (Max)	0x55	R	Unsigned short (GHz*10)	See §11.2	No		Manufacturer specific
		W					

#### Returns

	Data Value Returned in Response Upon			
	Successful Read	Successful Write	Error on Read	Error on Write
<b>Status Field Returned:</b>	OK		XE	
<b>Error Condition Field:</b>	OK		CIP, CII, EXF, or VSE	
<b>Data Value:</b>	Unsigned short		0x0000	
<b>Effect on Module</b>	None		Error field set	
Execution Time:	See §11.2		See §11.2	
<b>Pending Operation:</b>	Never			

#### Detailed Description

The register set (LFL1:LFL2) returns the lowest frequency of the laser. The register set (LFH1:LFH2) returns the highest frequency of the laser.

#### Data Value Description

The laser's first frequency is in GHz is equal to  $(0x52 \cdot 10^3 + 0x53 \cdot 10^{-1})$ .  
The laser's last frequency is in GHz is equal to  $(0x54 \cdot 10^3 + 0x55 \cdot 10^{-1})$ .

For instance, 194.175 THz would be represented by

Register	Hex Value	Decimal Value
0x52, 0x54	0x00C2	194
0x53, 0x55	0x06D6	1750

Frequency (GHz) is then  $194 \cdot 10^3 + 1750 \cdot 10^{-1}$

### 9.7.4 Laser's Minimum Grid Spacing (LGrid 0x56) [R]

#### Purpose

The LGrid register provides a way to read the minimum grid spacing capability of the module.

#### Synopsis:

Register Name	Register Number	Read / Write	Data Type Read or Written	Response Generated	Can Be Pending?	Volatile?	Default Contents
LGrid	0x56	R	Unsigned short (GHz*10)	See §11.2	No		Manufacturer specific
		W					

#### Returns

	Data Value Returned in Response Upon			
	Successful Read	Successful Write	Error on Read	Error on Write
<b>Status Field Returned:</b>	OK		XE	
<b>Error Condition Field:</b>	OK		CIP, CII, EXF, or VSE	
<b>Data Value:</b>	Unsigned short (GHz*10)		0x0000	
<b>Effect on Module</b>	None		Error field set	
<b>Execution Time:</b>	See §11.2		See §11.2	
<b>Pending Operation:</b>	Never			

#### Detailed Description

The LGrid register returns the laser's minimum grid spacing as a positive value.

#### Data Value Description

The value is represented as GHz\*10.

## 9.8 MSA Commands

### 9.8.1 Module Currents (Currents 0x57) [R]

#### Purpose:

Currents returns an array of the technology specific currents. These currents may include diode current(s), TEC currents, and monitor currents.

#### Synopsis:

Register Name	Register Number	Read / Write	Data Type Read or Written	Response Generated	Can Be Pending?	Volatile?	Default Contents
Currents	0x57	R	AEA (Array of signed int)	See §11.2	No		0x00xx → Current Array (mA*10)
		W					

#### Returns

	Data Value Returned in Response Upon			
	Successful Read	Successful Write	Error on Read	Error on Write
<b>Status Field Returned:</b>	OK		XE	
<b>Error Condition Field:</b>	OK		CIP, CII, EXF, or VSE	
<b>Data Value:</b>	0x00xx → Current Array (mA*10)		0x0000	
<b>Effect on Module</b>	AEA registers configured to reference array		Error field set	
<b>Execution Time:</b>	See §11.2		See §11.2	
<b>Pending Operation:</b>	Never			

#### Detailed Description

Returns key module currents as an array of signed integers. The first access of the Currents register returns a byte count to be read from the AEA register. At the time the Currents register is accessed, all the current values of the currents are copied into the field region where the AEA register will be configured for reading. The maximum length of the returned array 20 bytes.

All devices will report at least the first two currents but not more than 10 (20 byte length):

Number of Bytes	Technology 1	Technology 2	Technology 3
1:2	TEC	TEC	TEC
3:4	Diode	Diode 1	Diode 1
5:6		Diode 2	tbd
7:8		Diode 3	tbd
9:10		Diode 4	tbd
11:12		SOA	tbd
13:14			tbd
15:16			tbd
17:18			tbd
19:20			tbd

#### Data Value Description

Unless otherwise specified, currents are represented as unsigned integers (mA\*10).

### 9.8.2 Module Temperatures (Temps 0x58) [R]

**Purpose:**

Temps returns an array of the technology specific temperatures. These temperatures may include diode temperatures(s), and case temperatures.

**Synopsis:**

Register Name	Register Number	Read / Write	Data Type Read or Written	Response Generated	Can Be Pending?	Volatile?	Default Contents
Temps	0x58	R	AEA (Array of signed Int)	See §11.2	No		0x00xx → Temperature Array (°C*100)
		W					

**Returns**

	Data Value Returned in Response Upon			
	Successful Read	Successful Write	Error on Read	Error on Write
<b>Status Field Returned:</b>	OK		XE	
<b>Error Condition Field:</b>	OK		CIP, CII, EXF, or VSE	
<b>Data Value:</b>	0x00xx → Temperature Array (°C*100)		0x0000	
<b>Effect on Module</b>	AEA registers configured to reference array		Error field set	
<b>Execution Time:</b>	See §11.2		See §11.2	
<b>Pending Operation:</b>	Never			

**Detailed Description**

Returns key module temperatures as an array of signed integers. The first access of the Temps register returns a byte count to be read from the AEA register. At the time the Temps register is accessed, all the temperature values of the temperatures are copied into the field region where the AEA register will be configured for reading. The maximum length of the returned array 20 bytes.

All devices will report the following currents:

Number of Bytes	Technology 1	Technology 2
1:2	Diode Temp	Diode Temp
3:4	Case Temp	Case Temp

**Data Value Description**

Unless otherwise specified, temperatures are represented as signed integers (°C\*100).

### 9.8.3 Digital Dither (Dither(E,R,A,F) 0x59-0x5C) [RW] [Optional]

#### Purpose

The dither registers provide a way to configure dither performance of the units. The digital dither is an optional features. For consistency among the various technologies, digital dither is the preferred implementation.

#### Synopsis:

Register Name	Register Number	Read / Write	Data Type Read or Written	Response Generated	Can Be Pending?	Volatile?	Default Contents
DitherE	0x59	R	Unsigned short	See §11.2	No	Non-volatile	Manufacturer specific
		W		See §11.2	Yes		
DitherR	0x5A	R	Unsigned short (KHz)	See §11.2	No	Non-volatile	Manufacturer Specific (10KHz – 200kHz)
		W		See §11.2	Yes		
DitherF	0x5B	R	Unsigned short (GHz*10)	See §11.2	No	Non-volatile	Manufacturer specific
		W		See §11.2	No		
DitherA	0x5C	R	Unsigned short (%*10)	See §11.2	No	Non-volatile	Manufacturer specific
		W		See §11.2	No		

#### Returns

	Data Value Returned in Response Upon			
	Successful Read	Successful Write	Error on Read	Error on Write
<b>Status Field Returned:</b>	OK	OK	XE	XE
<b>Error Condition Field:</b>	OK	OK	CIP, CII, EXF, or VSE	RNW, CIP, CII, EXF, CIE, or VSE
<b>Data Value:</b>	Unsigned short	Same as sent or pending ID	0x0000	0x0000
<b>Effect on Module</b>	None	Configured	Error field set	Error field set
<b>Execution Time:</b>	See §11.2	See §11.2	See §11.2	See §11.2
<b>Pending Operation:</b>	Never	Technology Dependent		

#### Detailed Description

The use of dither generally falls into two categories: 1) SBS suppression, and/or 2) signaling. SBS suppression is primarily concerned with FM frequency deviation and traditionally may monitor the AM content as a measure of the FM content. The signaling application makes use of either a sinusoidal tone or an AM modulated signal. The signaling application may also be used in conjunction with SBS suppression.

Some laser technologies must generate AM content to achieve the desired FM content while other can achieve AM and FM contents independently. The configuration registers provides the ability to set the FM deviation with the DitherF register and the AM content with the DitherA register. For a given application, it is recommended that either the DitherA or the DitherF register be configured. Configuring both may lead to an over constrained system.

Enabling or disabling dither is a non-interrupting traffic event.

The default is manufacturer specific and can be modified when the module configuration is stored in non-volatile memory.



Typical Dither Configurations	Register			
	Application	DitherE	DitherR	DitherA
<b>AM Tone Signaling</b>	0x0002 (Sinusoidal)	100-200kHz	Configure (~5%)	Not configured
<b>SBS Suppression (Pure)</b>	0x0012 (Triangular)	10-50kHz <sup>41</sup>	Not configured	0.1-1GHz
<b>AM Tone + SBS (potentially over constrained)<sup>42</sup></b>	0x0002 (Sinusoidal)	100-200kHz	Configure (~5%)	Not configured

DitherF, DitherR, and DitherA can only be changed when the digital dither is disabled. Changing it while the output is enabled will generate an execution error. Values not supported by the module also generate execution errors. The contents of the registers are unsigned integers.

#### Data Value Description

DitherR is an unsigned integer specifying the dither rate as kHz. Note that DitherE is used to set the waveform for this frequency.

DitherF is an unsigned short integer encoded as the FM p-p frequency deviation as GHz\*10.

DitherA is an unsigned short integer encoded as the AM p-p amplitude deviation as 10\*percentage of the optical power.

DitherE is an unsigned short integer encoded as shown below.

15	14	13	12	11	10	9	8	7	6	5	4	3	2	1	0
										WF				DDE (Digital Dither Enable)	

Digital Dither Enable (Bit 1)

0x00 – No dither is enabled.

0x01 – Digital dither is enabled (configured through DitherF and DitherA registers)

WF (Waveform) (Bits 5:4)

0x00 – Sinusoidal

0x01 – Triangular (symmetrical)

<sup>41</sup> The granularity in setting the DitherR rate is manufacturer dependent. The module will default to the closest DitherR value supported.

<sup>42</sup> In technologies where the SBS may be over constrained, the SBS may occur at the “pure SBS” DitherR default value and the AM tone is produced at the specified DitherR value.

### 9.8.4 TBTF Warning Limits (TBTFH, TBTFH 0x5D, 0x5E) [RW]

#### Purpose

The TBTF registers set the warning limits for high and low temperature for the thermal warning.

#### Synopsis:

Register Name	Register Number	Read / Write	Data Type Read or Written	Response Generated	Can Be Pending?	Volatile?	Default Contents
TBTFH	0x5D	R	Signed short (°C*100)	See §11.2	No	Non-volatile	0xFE0C (-5 °C)
		W		See §11.2	No		
TBTFH	0x5E	R	Signed short (°C*100)	See §11.2	No	Non-volatile	0x1B58 (+70°C)
		W		See §11.2	No		

#### Returns

	Data Value Returned in Response Upon			
	Successful Read	Successful Write	Error on Read	Error on Write
<b>Status Field Returned:</b>	OK	OK	XE	XE
<b>Error Condition Field:</b>	OK	OK	CIP, CII, EXF, or VSE	RNW, RVE, CIP, CII, EXF, or VSE
<b>Data Value:</b>	Signed short (°C*100)	Same as sent	0x0000	0x0000
<b>Effect on Module</b>	None	New warning levels take effect	Error field set	Error field set
<b>Execution Time:</b>	See §11.2	See §11.2	See §11.2	See §11.2
<b>Pending Operation:</b>	Never	Never		

#### Detailed Description

The temperature limits are set by TBTFH and TBTFH. When the base of the butterfly temperature as determined by the laser module exceeds either of the limits for at least 5 seconds,

- TBTF > TBTFH
- TBTF < TBTFH

The thermal warning flag (WTherm) is asserted in the StatusW (0x21) register.

The default is manufacturer specific and can be modified when the module configuration is stored in non-volatile memory.

#### Data Value Description

The temperature is encoded as a signed short integer as °C\*100 which allows a temperature range of ±327 °C.

### 9.8.5 Age Threshold (FAgeTh, WAgeTh 0x5F, 0x60) [RW]

#### Purpose

FAgeTh specifies the maximum end of life (EOL) percent aging at which the fatal alarm is asserted.

WAgeTh specifies the maximum end of life (EOL) percent aging at which the warning alarm is asserted.

See §9.8.6, Laser Age (Age 0x61) [R].

#### Synopsis:

Register Name	Register Number	Read / Write	Data Type Read or Written	Response Generated	Can Be Pending?	Volatile?	Default Contents
FAgeTh	0x5F	R	Unsigned short %	See §11.2	No	Non-volatile	Manufacturer specific
		W		See §11.2	No		
WAgeTh	0x60	R	Unsigned short %	See §11.2	No	Non-volatile	Manufacturer specific
		W		See §11.2	No		

#### Returns

	Data Value Returned in Response Upon			
	Successful Read	Successful Write	Error on Read	Error on Write
<b>Status Field Returned:</b>	OK	OK	XE	XE
<b>Error Condition Field:</b>	OK	OK	CIP, CII, EXF, or VSE	RNW, RVE, CIP, CII, EXF, or VSE
<b>Data Value:</b>	%	% (Same as sent)	0x0000	0x0000
<b>Effect on Module</b>	None	New tolerance takes effect	Error field set	Error field set
<b>Execution Time:</b>	See §11.2	See §11.2	See §11.2	See §11.2
<b>Pending Operation:</b>	Never	Never		

#### Detailed Description

The value is stored in percent as an unsigned integer. Setting a value outside of the usable range will result in an execution error flag (XE) and an error field setting of RVE (range value error). The default is manufacturer specific and can be modified when the module configuration is stored in non-volatile memory.

When the threshold is exceeded for FAgeTh, the FVSF flag in StatusF (0x20) is asserted.

When the threshold is exceeded for WAgeTh, the WVSF flag in StatusW (0x21) is asserted.

#### Data Value Description

The value is stored in percentage as an unsigned integer (0 to 100). The fatal threshold (FAgeTh) would typically be set at 100 or less. The warning threshold (WAgeTh) would typically be set to a value greater than 0 and less than the FAgeTh value.

Condition	Threshold Setting
BOL (Beginning of Life)	0x0000 (000 <sub>10</sub> )
EOL (End of Life)	0x0064 (100 <sub>10</sub> )

### 9.8.6 Laser Age (Age 0x61) [R]

#### Purpose

The Age register provides a way to read the percent aging of the laser. The range is between 0% (indicating beginning of life) to 100% (specifying the laser has reached end of life and requires replacement).

#### Synopsis:

Register Name	Register Number	Read / Write	Data Type Read or Written	Response Generated	Can Be Pending?	Volatile?	Default Contents
Age	0x61	R	Unsigned short (% EOL)	See §11.2	No		Manufacturer specific
		W					

#### Returns

	Data Value Returned in Response Upon			
	Successful Read	Successful Write	Error on Read	Error on Write
<b>Status Field Returned:</b>	OK		XE	
<b>Error Condition Field:</b>	OK		CIP, CII, EXF, or VSE	
<b>Data Value:</b>	Unsigned short (% EOL)		0x0000	
<b>Effect on Module</b>	None		Error field set	
<b>Execution Time:</b>	See §11.2		See §11.2	
<b>Pending Operation:</b>	Never			

#### Detailed Description

The age is reported as an unsigned integer encoded in percent of end of life (EOL). This register is intended to be a general representation of laser aging attempting to cover various tunable technologies.

“End of Life” (register contents  $100_{10}$ ) is defined as the laser being unable to meet the specifications on this channel (channel specified in the channel register (0x30)) and or any other valid channel<sup>43</sup>.

It can be mated with the laser bias current pin and register for the 300pin transponder MSA using an appropriate mapping. This register displays the percent value which is used to determine if a fatal or warning condition has occurred via registers FAgeTh and WAgeTh.

#### Data Value Description

The percentage is represented as an unsigned short integer.

Condition	Register Value
BOL (Beginning of Life)	0x0000
EOL (End of Life)	0x0064

<sup>43</sup> This definition implies that as long as the contents of the register is less than 100, the transponder can be sure that a channel switch to any valid channel (frequency) and/or a power adjustment to any valid power level will be successful from an module aging perspective.

### 9.8.7 Fine Tune Frequency (FTF 0x62) [RW]

#### Purpose

The FTF register provides fine tune adjustment of the laser's wavelength from the set channel. The adjustment is applied to all channels uniformly.

#### Synopsis:

Register Name	Register Number	Read / Write	Data Type Read or Written	Response Generated	Can Be Pending?	Volatile?	Default Contents
FTF	0x62	R	Signed short (MHz)	See §11.2	No	volatile	0x0
		W		See §11.2	Yes	volatile	

#### Returns

	Data Value Returned in Response Upon			
	Successful Read	Successful Write	Error on Read	Error on Write
<b>Status Field Returned:</b>	OK	OK	XE	XE
<b>Error Condition Field:</b>	OK	OK	CIP, RNI, CII, EXF, or VSE	RNW, RNI, CIP, CII, EXF, VSE, or RVE
<b>Data Value:</b>	Signed short (MHz)	Same as sent	0x0000	0x0000
<b>Effect on Module</b>	None	Configured	Error field set	Error field set
<b>Execution Time:</b>	See §11.2	See §11.2	See §11.2	See §11.2
<b>Pending Operation:</b>	Never	Typically for most technologies		

#### Detailed Description

Fine tune frequency provides off-grid tuning of the laser wavelength. It is typically used after the laser is locked, and minor adjustments are required to the frequency. The frequency can be adjusted in both the positive and negative direction. The command is non-service interrupting when channel is locked. If the FTF command is issued when the laser is not enabled (SENA = 0), the laser frequency will be set to the sum of the channel frequency and the FTF frequency when the laser output is enabled. The command may be pending in the event that the laser output is enabled. The pending bit is cleared once the fine tune frequency has been achieved. As with the channel command, while the laser is making a fine tune adjustment, the WFREQ bit (and therefore the ALM<sup>44</sup> bit) is asserted, if the alarm during tuning (ADT) bit is set.

#### Data Value Description

The frequency is in MHz and supports both positive and negative frequency shift values.

For instance, a shift of -5 GHz from 194.1750 to yield 194.170 would result in setting the FTF register to -5000.

The default value is zero.

<sup>44</sup> The ALM bit behaves as an "is locked" indicator and presumes that the ADT bit is asserted and the ALMT bits are set appropriately.

### **9.9 Manufacturer Specific (0x80-0xFE)**

These registers are reserved for manufacturer specific needs.

## 10 Alarm and Status Register Behavior

### 10.1 Introduction

Implementing module status and associated alarm commands in a consistent manner for various laser technologies (see Section 9.5) can be challenging. This section provides some guidelines on the intended behavior of the module status commands to aid in a consistent implementation across laser manufacturers.

### 10.2 StatusF/StatusW Register Definitions

The primary purpose of StatusF is to report fatal conditions. The primary purpose of StatusW is to report warning conditions. See Section 9.5.1 for details.

Fatal conditions imply that the laser is operating in (a) a range that will be damaging to the unit, (b) adversely affect traffic or (c) requires immediate servicing. The shutdown on fault condition (SDF bit in Register MCB 0x33) is linked to the FATAL bit of the status register.

Warning conditions indicate that the laser is operating outside of its optimal range and should be investigated and potentially serviced soon. The warning conditions can also be configured as a LOCKED indicator when the Alarm During Tuning (ADT see MCB 0x33 register) bit is set. In this case, only when the laser completes tuning do the warning conditions take on their original meaning of notifying the host that the laser is operating outside of its optimal region. The ALM bit reflects the warning conditions when properly masked by the ALMT register.

The SRQ\* (Service Request) line is intended to notify the customer of any alarm conditions or fatal issues that may require servicing of the unit or customer action. Hardware lines are depicted by the "\*" character for the associated bit (active low). For example, SRQ\* is referred to the hardware line associated with the SRQ bit in the status register. SRQ = 1 implies SRQ\* low, and SRQ = 0 implies SRQ\* high.

Table 10.2-1 and Table 10.2-2 denote the data formats of the status registers.

**Table 10.2-1: Status Fatal register 0x20 (StatusF) description**

15	14	13	12	11	10	9	8
SRQ	ALM	FATAL	DIS	FVSF	FFREQ	F THERM	FPWR
7	6	5	4	3	2	1	0
XEL	CEL	MRL	CRL	FVSFL	FFREQ L	F THERML	FPWRL

**Table 10.2-2: Status Warning register 0x21 (StatusW) description**

15	14	13	12	11	10	9	8
SRQ	ALM	FATAL	DIS	WVSF	WFREQ	W THERM	WPWR
7	6	5	4	3	2	1	0
XEL	CEL	MRL	CRL	WVSFL	WFREQ L	W THERML	WPWRL

Additional triggering registers are used to determine the state of various status bits. Table 10.2-3, Table 10.2-4 and Table 10.2-5 denote the data formats and default values of triggering registers.

**Table 10.2-3: SRQ Trigger register 0x28 (SRQT) description**

15	14	13	12	11	10	9	8
			DIS	WVSFL	WFREQL	W THERML	WPWRL
0	0	0	1	1	1	1	1
7	6	5	4	3	2	1	0
XEL	CEL	MRL	CRL	FVSFL	FFREQL	F THERML	FPWRL
1	0	1	1	1	1	1	1

**Table 10.2-4: Fatal Trigger register 0x29 (FATALT) description**

15	14	13	12	11	10	9	8
				WVSFL	WFREQL	W THERML	WPWRL
0	0	0	0	0	0	0	0
7	6	5	4	3	2	1	0
		MRL		FVSFL	FFREQL	F THERML	FPWRL
0	0	0	0	1	1	1	1

**Table 10.2-5: Alarm Trigger register 0x2A (ALMT) description**

15	14	13	12	11	10	9	8
				WVSF	WFREQ	W THERM	WPWR
0	0	0	0	1	1	0	1
7	6	5	4	3	2	1	0
				FVSF	FFREQ	F THERM	FPWR
0	0	0	0	1	1	0	1

The SRQ, FATAL and ALM bits are direct reflections of combining the respective SRQT, FATALT and ALMT trigger registers with the status registers<sup>45</sup>. The operations for combining are discussed in Section 10.3.

### 10.3 Status Bit Determination Conditions and Behavior

Table 10.3-1 denotes the determination conditions for each bit in the status registers. Status bits are dependent upon various internal conditions, trigger registers and the ADT bit in the MCB register (0x33). Note that bits 4-7 and 12-15 are shared among registers StatusF and StatusW. Non-latched status bits are cleared to 0 when the “Set to 1 condition” is false. Latched status bits (names ending with “L”, e.g. FPWRL, F THERML) are cleared to 0 by writing a 1 to the corresponding bit position (writing accomplished by host).

**Table 10.3-1: Determination conditions for each bit in the status register**

Bit Name	Bit Description	How bit is set to 1 condition	How bit is cleared to 0 condition
FPWR	Fatal power	Optical power is outside of fatal threshold (FPowTh) range during lock, or failure in	The “How bit is set to 1

<sup>45</sup> The SRQ and Fatal lines do have an exception to this rule. During tuning the conditions are not triggered under certain circumstances. See Sections 9.5.5 and 9.5.6, SRQ and Fatal Triggers for additional details.



		power locker			condition" is false
FTHERM	Fatal temperature	Temperature is outside of fatal threshold (FTermTh) range, or hardware failure in temperature stabilizer			The "How bit is set to 1 condition" is false
FFREQ	Fatal frequency	Frequency is outside of frequency threshold (FFreqTh) range during lock, or failure in frequency locker			The "How bit is set to 1 condition" is false
FVSF	Fatal vendor specific fault	Laser age exceeds fatal age threshold (FAgeTh) or vendor specific fatal occurs in laser			The "How bit is set to 1 condition" is false
FPWRL	Fatal power latched	FPWR is set to 1			Host write 1 to this bit
FTHERML	Fatal temperature latched	FTHERM is set to 1			Host write 1 to this bit
FFREQQL	Fatal frequency latched	FFREQ is set to 1			Host write 1 to this bit
FVSFL	Fatal vendor specific fault latched	FVSF is set to 1			Host write 1 to this bit
WPWR	Warning power	<b>Laser off and ADT = 1</b>	<b>During Tuning and ADT = 1</b>	<b>Laser In Steady State</b>	The "How bit is set to 1 condition" is false. Note: When laser off and ADT = 0 this condition is always true (bit is zero).
		1	Outside of threshold range (WPowTh)	Outside of threshold range (WPowTh)	
WTHERM	Warning temperature	<b>Laser off and ADT = 1</b>	<b>During Tuning and ADT = 1</b>	<b>Laser In Steady State</b>	The "How bit is set to 1 condition" is false
		Outside of threshold range (WThermTh)	Outside of threshold range (WThermTh)	Outside of threshold range (WThermTh)	
WFREQ	Warning frequency	<b>Laser off and ADT = 1</b>	<b>During Tuning and ADT = 1</b>	<b>Laser In Steady State</b>	The "How bit is set to 1 condition" is false. Note: When laser off and ADT = 0 this condition is always true (bit is zero).
		1	Outside of threshold range (WFreqTh)	Outside of threshold range (WFreqTh)	
WVSF	Warning vendor specific fault	At any time, laser age exceeds warning age threshold (WAgeTh)			The "How bit is set to 1 condition" is

			false
WPWRL	Warning power latched	WPWR is set to 1	Host write 1 to this bit
WTHERML	Warning temperature latched	WTHERM is set to 1	Host write 1 to this bit
WFREQL	Warning frequency latched	WFREQ is set to 1	Host write 1 to this bit
WVSFL	Warning vendor specific fault latched	WVSF is set to 1	Host write 1 to this bit
CRL	Communication reset latched	Module select (MS*) transitions from low to high, or module reset RESENA.MR = 1, or power cycle, or software reset RESENA.SR = 1, or communication timeout	Host write 1 to this bit
MRL	Module restarted latched	Module reset (RST*) or, power cycle, or RESENA.MR = 1	Host write 1 to this bit
CEL	Communication error latched	Module receives a packet containing invalid checksum	Host write 1 to this bit
XEL	Execution error latched	Module receives a non-conforming command resulting in an execution error	Host write 1 to this bit
DIS	Module output disable	DIS* line is low	DIS* line is high
FATAL	Fatal condition	((FATALT >> 8) & 0x0F & StatusW)    (FATALT & 0x0F & StatusF)    (FATALT & MRL) <sup>46</sup>	The "How bit is set to 1 condition" is false
ALM	Alarm condition	(ALMT & 0x0F00 & StatusW)    (ALMT & 0x000F & (StatusF >> 8))	The "How bit is set to 1 condition" is false
SRQ	Service request	((SRQT >> 8) & 0x0F & StatusW)    (SRQT & 0x0F & StatusF)    (SRQT & (DIS   XEL   CEL   MRL   CRL)) <sup>47</sup>	The "How bit is set to 1 condition" is false

#### 10.4 Effects of Alarm During Tuning (ADT) bit in MCB register (0x33)

The ADT bit reflects two modes of operation which affect the determination conditions for status bits WTHERM, WPWR and WFREQ. When ADT = 1, the ALM bit along with the warning conditions function as a LOCKED indicator. When ADT = 0, the ALM bit and warning conditions are used to notify the host of any abnormal laser operation and should be investigated. Table 10.3-1 contains the conditions for ADT for the WFREQ, WPWR, and WTHERM bits.

With ADT = 1, WFREQ is set to 1 while laser is tuning prior to frequency lock. (frequency lock is considered to occur when frequency is within WFreqTh). After frequency lock, WFREQ is determined by checking the output frequency against the warning frequency threshold. Note: that not all technologies have the sampling rate to determine during tuning if the frequency is within the threshold parameters. In this case, maintaining the WFREQ during tuning is sufficient. It is also sufficient to maintain WFREQ if the locker has not achieved steady state.

<sup>46</sup> See Section 9.5.6, FatalT for exception during tuning.

<sup>47</sup> See Section 9.5.5, SRQT for exception during tuning.

Similarly, WPWR is set to 1 while laser is tuning prior to power lock when ADT = 1. After power lock, WPWR is determined by checking the output power against the warning power threshold. Note: that not all technologies have the sampling rate to determine during tuning if the power is within the threshold parameters. In this case, maintaining the WPWR during tuning is sufficient.

WTherm may be asserted with ADT = 1, if the measured temperature is outside of the warning threshold range.

WFREQ, WPWR and WTherm can be used as lock indicators. However, the pending field in the NOP register (0x00) will only be cleared after the laser output has reached a steady state. With ALMT properly configured, one can use the ALM bit to determine when to transmit. To guarantee complete settling of the laser to the steady state operating point, the host should wait until the pending field in the NOP register is cleared.

When ADT is 0, WFREQ, WPWR and WTherm reflect the true nature of the laser's alarm conditions. Typical behavior will have no alarms (ALM = 0) during tuning. If an alarm condition is asserted, investigation should occur to understand the abnormal behavior. WFREQ is cleared to 0 while laser is tuning prior to frequency lock. After frequency lock, WFREQ is determined by checking the output frequency against the warning frequency threshold. Similarly, WPWR is cleared to 0 while laser is tuning prior to power lock. After power lock, WPWR is determined by checking the output power against the warning power threshold. WTherm is asserted only if the temperature is outside of the WThermTh range for all conditions (laser off, laser tuning, laser locked).

## 11 Optical Specifications

Unless otherwise noted, all optical specifications are over life, temperature, and other environmental conditions.

### 11.1 Optical Characteristics

The required optical specifications for tunable lasers are very dependent upon application.

The optical performance specifications are divided into a matrix of application requirements as shown in Table 11.1-1.

**Table 11.1-1: Optical Specification Requirement Matrix**

Optical Specification Matrix			Application Requirement (Tuning Speed)		
			A	B	C
			SONET/SDH Protection	SONET/SDH Restoration	Provisioning & Sparing
Application Requirement	1	Ultra Long Haul	A1	B1	C1
	2	Long Haul	A2	B2	C2
	3	Metro	A3	B3	C3

#### 11.1.1 Optical Parameter Definitions

For the following optical application requirements, the following terms are defined.

##### 11.1.1.1 Frequency Tuning Range

The minimum and maximum frequencies encompassing the grid points over which the module may be tuned over life and environmental conditions.

##### 11.1.1.2 Fiber Output Power

The minimum and maximum fiber coupled output power for all channels over life and environmental conditions.

##### 11.1.1.3 Output Power Variation Across Tuning Range

The minimum to maximum power variation across the entire tuning range measured at any point during the life of the module including environmental effects.

##### 11.1.1.4 Frequency Error to the ITU Grid

The difference between the time averaged (1s interval) frequency and the selected ITU grid frequency over life.

##### 11.1.1.5 Spectral Linewidth

The linewidth specified is the Lorentzian component and is related to white phase noise component of the optical field. It is defined as the -3dB full width of a self-heterodyne (3.5us delay) measurement. Typically one arm of the interferometer is shifted in frequency.

##### 11.1.1.6 SMSR (Side Mode Suppression Ratio)

Defined as the ratio of the average optical power in the dominant longitudinal mode to the optical power of the most significant side mode at CW, in the presence of worst-case reflections (-8.2dBc<sup>48</sup>).

##### 11.1.1.7 RIN (Relative Intensity Noise)

Measured from 10MHz to 10GHz in the presence of worst-case reflections (-8.2dBc).

<sup>48</sup> The term “dBc” indicates that a power ratio is expressed in decibels referenced to the carrier.

- 11.1.1.8 Source Spontaneous Emission  
Defined as the maximum background emission power level with respect to the lasing frequency peak power and is measured over a 0.1nm bandwidth.
- 11.1.1.9 Polarization Extinction Ratio  
The ratio of maximum optical power in the output fiber measured through a polarizing filter to the optical power measured at 90°.
- 11.1.1.10 Optical Attenuation  
The maximum fiber output power referenced to the un-attenuated fiber output power expressed in dB when the lasing frequency is not within the specified frequency limits for the given channel (over life and environment).

### 11.1.2 Application Requirement 1 (Ultra Long Haul)

Table 11.1-2 shows the optical specifications for the CW tunable laser for Application 1.

**Table 11.1-2: Optical Specifications (Application 1)**

Item	Parameter		Sym	Min	Typ	Max	Unit
11.1.2.1	Frequency tuning range <sup>49</sup>		$N$	186.000		196.575	THz
			$\lambda$	~1525		~1612	nm
11.1.2.2	Fiber Output Power (Over lifetime and all operating conditions)	20mW	P	12.5	13.5	14.5	dBm
		10mW		9.5	10.5	11.5	
11.1.2.3	Output power variation across tuning range		$\Delta P$			0.5	dB
11.1.2.4	Frequency error to ITU Grid	50 GHz channel spacing	$\Delta F$	-2.5		+2.5	GHz
11.1.2.5		25 GHz channel spacing	$\Delta F$	-1.25		+1.25	GHz
11.1.2.6	Side Mode Suppression Ratio		SMSR	43			dB
11.1.2.7	Relative Intensity Noise		RIN			-145	dB/Hz
11.1.2.8	Spectral Linewidth		$\delta f$			5	MHz
11.1.2.9	Optical isolation			25			dB
11.1.2.10	Source Spontaneous Emission		SSE			-50	dBc
11.1.2.11	Polarization Extinction Ratio over tuning range		PER	20			dB
11.1.2.12	Optical attenuation while tuning or while module enabled or disabled (while $ \Delta F  > 10\text{GHz}$ ) <sup>50</sup>		$P_{\text{ATT1}}$	30			dB
11.1.2.13	Optical attenuation while tuning or while module enabled or disabled (while $ \Delta F  \leq 10\text{GHz}$ )		$P_{\text{ATT2}}$	0			dB

<sup>49</sup> The frequency tuning range shown is informative, not normative. It is expected to be inclusive of all applications and of ITU recommendation G.698.1. The tuning range is typically application specific and is often a subset of the range shown. Applications will likely require a subset of this tuning range capability. Lasers need not necessarily support the entire tuning range unless required by an application.

<sup>50</sup>  $|\Delta F|$  refers to the frequency error with respect to the desired ITU grid point.

### 11.1.3 Application Requirement 2 (Long Haul)

Table 11.1-3 shows the optical specifications for the CW tunable laser for Application 2.

**Table 11.1-3: Optical Specifications (Application 2)**

Item	Parameter		Sym	Min	Typ	Max	Unit
11.1.3.1	Frequency tuning range <sup>51</sup>		$\nu$	186.000		196.575	THz
			$\lambda$	~1525		~1612	nm
11.1.3.2	Fiber Output Power (Over lifetime and all operating conditions)	20mW	P	12.5	13.5	14.5	dBm
		10mW		9.5	10.5	11.5	
11.1.3.3	Output power variation across tuning range		$\Delta P$			0.5	dB
11.1.3.4	Frequency error to ITU Grid	50 GHz channel spacing	$\Delta F$	-2.5		+2.5	GHz
11.1.3.5		25 GHz channel spacing	$\Delta F$	-1.25		+1.25	GHz
11.1.3.6	Side Mode Suppression Ratio		SMSR	40			dB
11.1.3.7	Relative Intensity Noise		RIN			-135	dB/Hz
11.1.3.8	Spectral Linewidth		$\delta f$			10	MHz
11.1.3.9	Optical isolation			25			dB
11.1.3.10	Source Spontaneous Emission		SSE			-50	dBc
11.1.3.11	Polarization Extinction Ratio over tuning range		PER	20			dB
11.1.3.12	Optical attenuation while tuning or while module enabled or disabled (while $ \Delta F  > 10\text{GHz}$ ) <sup>52</sup>		$P_{\text{ATT1}}$	30			dB
11.1.3.13	Optical attenuation while tuning or while module enabled or disabled (while $ \Delta F  \leq 10\text{GHz}$ )		$P_{\text{ATT2}}$	0			dB

<sup>51</sup> The frequency tuning range shown is informative, not normative. It is expected to be inclusive of all applications and of ITU recommendation G.698.1. The tuning range is typically application specific and is often a subset of the range shown. Applications will likely require a subset of this tuning range capability. Lasers need not necessarily support the entire tuning range unless required by an application.

<sup>52</sup>  $|\Delta F|$  refers to the frequency error with respect to the desired ITU grid point.

### 11.1.4 Application Requirement 3 (Metro)

Table 11.1-4: shows the optical specifications for the CW tunable laser for Application 3.

**Table 11.1-4: Optical Specifications (Application 3)**

Item	Parameter		Sym	Min	Typ	Max	Unit
11.1.4.1	Frequency tuning range <sup>53</sup>		$\nu$	186.000		196.575	THz
			$\lambda$	~1525		~1612	nm
11.1.4.2	Fiber Output Power (Over lifetime and all operating conditions)	20mW	P	12.5	13.5	14.5	dBm
		10mW		9.5	10.5	11.5	
11.1.4.3	Output power variation across tuning range		$\Delta P$			0.5	dB
11.1.4.4	Frequency error to ITU Grid	50 GHz channel spacing	$\Delta F$	-2.5		+2.5	GHz
11.1.4.5		25 GHz channel spacing	$\Delta F$	-1.25		+1.25	GHz
11.1.4.6	Side Mode Suppression Ratio		SMSR	35			dB
11.1.4.7	Relative Intensity Noise		RIN			-130	dB/Hz
11.1.4.8	Spectral Linewidth		$\delta F$			20	MHz
11.1.4.9	Optical isolation			25			dB
11.1.4.10	Source Spontaneous Emission		SSE			-40	dBc
11.1.4.11	Polarization Extinction Ratio over tuning range		PER	18			dB
11.1.4.12	Optical attenuation while tuning or while module enabled or disabled (while $ \Delta F  > 10\text{GHz}$ ) <sup>54</sup>		$P_{\text{ATT1}}$	30			dB
11.1.4.13	Optical attenuation while tuning or while module enabled or disabled (while $ \Delta F  \leq 10\text{GHz}$ )		$P_{\text{ATT2}}$	0			dB

<sup>53</sup> The frequency tuning range shown is informative, not normative. It is expected to be inclusive of all applications and of ITU recommendation G.698.1. The tuning range is typically application specific and is often a subset of the range shown Applications will likely require a subset of this tuning range capability. Lasers need not necessarily support the entire tuning range unless required by an application.

<sup>54</sup>  $|\Delta F|$  refers to the frequency error with respect to the desired ITU grid point.



## 11.2 Timing Specifications

Three application requirements are shown below for tunable laser tuning times.

Table 11.2-1: Timing Specifications

Item	Parameter	Sym	Min	Typ	Max	Unit
11.2.1	Frequency tuning time (Frequency is within frequency accuracy / stability spec)	Application A (SONET/SDH Protection)	$t_T$		10	ms
11.2.2		Application B (SONET/SDH Restoration)	$t_T$		1	s
11.2.3		Application C (Sparing/Provisioning)	$t_T$		30	s
11.2.4	Maximum time allowed for module to construct a response packet	Application A (SONET/SDH Protection)	$t_T$		5	ms
11.2.5		Application B (SONET/SDH Restoration)	$t_T$		50	ms
11.2.6		Application C (Sparing/Provisioning)	$t_T$		50	ms

## 11.3 Module Warm Up Time

Table 11.3-1: Module Warm Up Time

Item	Parameter	Sym	Min	Typ	Max	Unit
11.3.1	Module warm up time. (The worst case delay, from power up or hard reset, until the module asserts ready <sup>55</sup> (MRDY bit in the NOP (0x00) register)	$T_{WU}$			60	s

## 11.4 Frequency and Optical Power Transient Specifications

Tunable technologies may have various transient behaviors for initial tune and between channel tuning. **Error! Reference source not found.** provides the baseline frequency and power transient masks for the various application spaces specified in Table 11.1-1. The masks highlight the expectations for timing and overshoot.

<sup>55</sup> Assuming a valid configuration of the module.

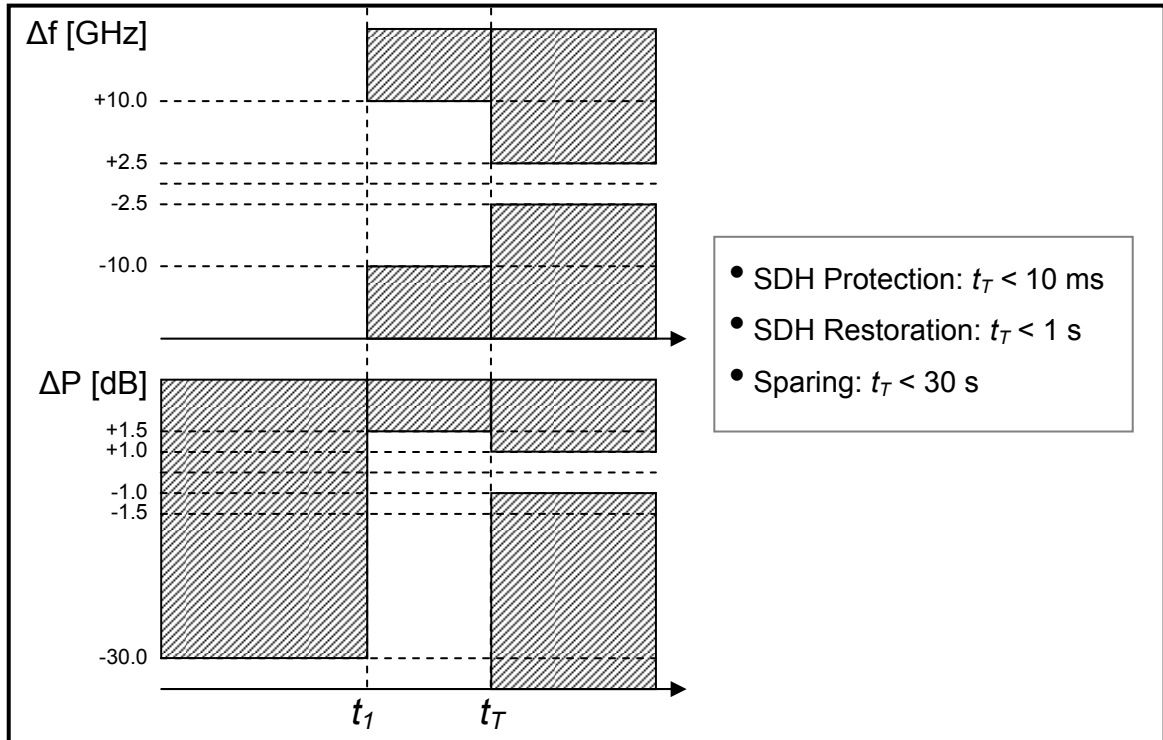


Figure 11.4-1: Frequency and power transient mask.  $t_1$  is manufacturer specific.

## 12 Mechanical Specifications

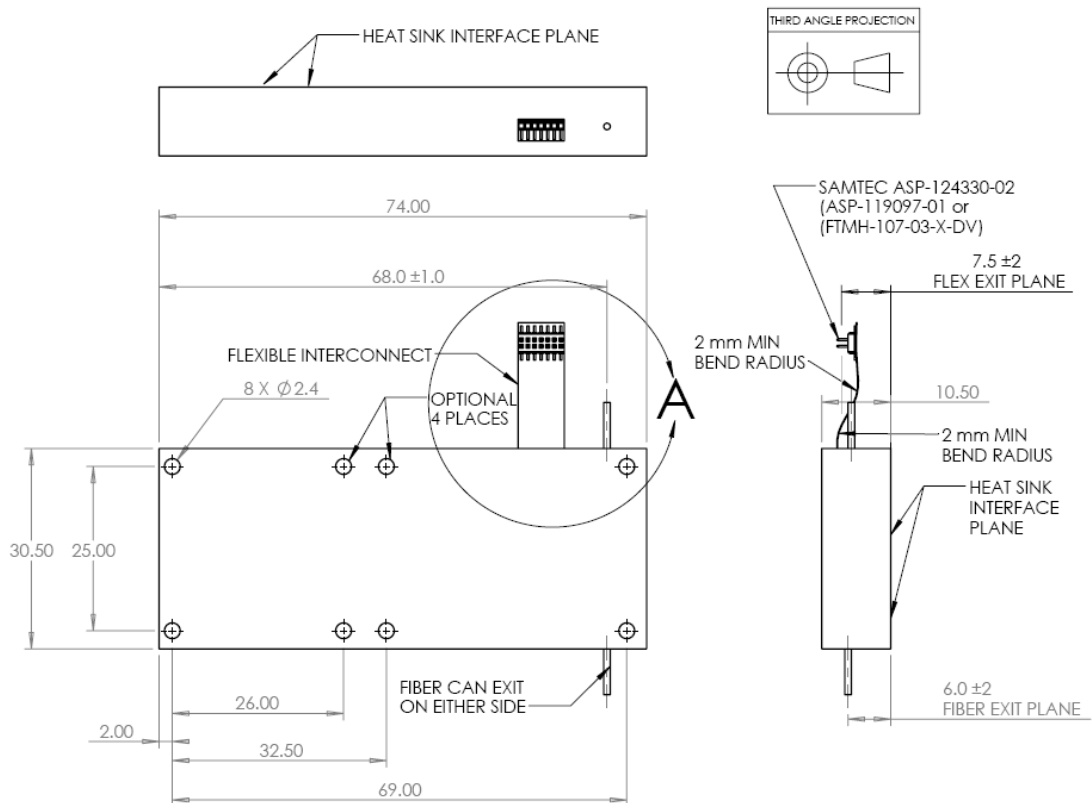
### 12.1 Integrable Assembly Mechanical Outline Dimensions

**Error! Reference source not found.** details the mechanical outline of the ITLA as a block form factor. Note that the ITLA is not encased in its own housing. See §7.1.1 for details on the electrical connection.

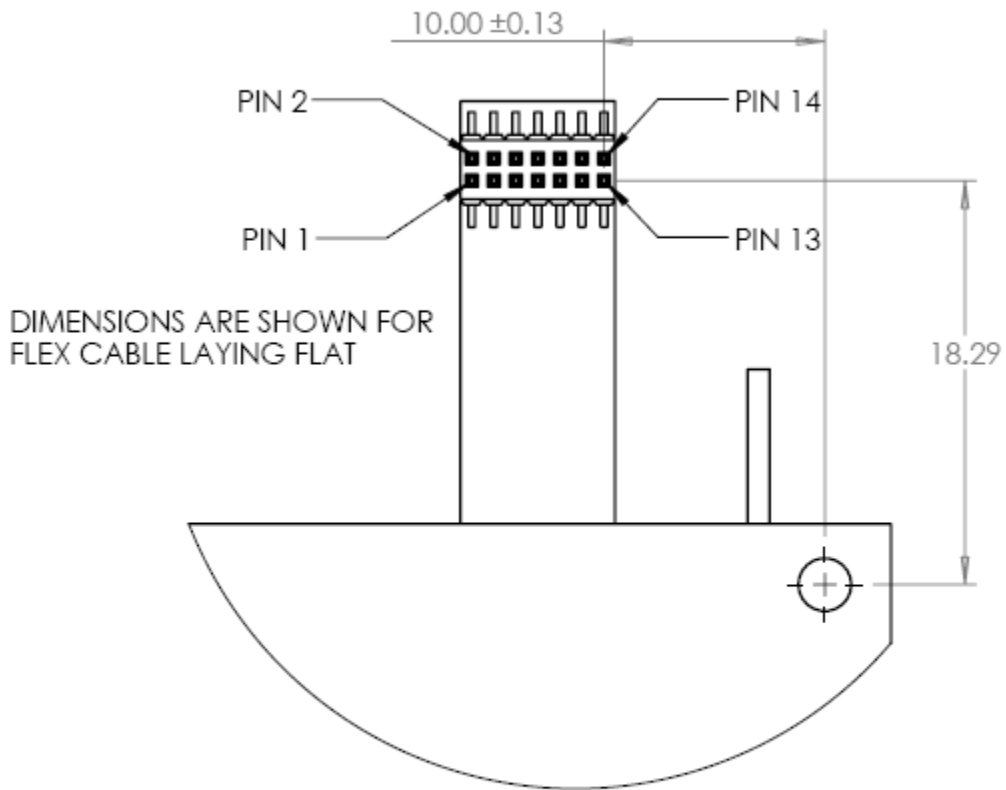
The minimum fiber bend radius is 20mm. The may optionally exit either side of the ITLA.

The drawing indicates placement for eight mounting holes. Only four mounting holes at either end are required. The use of the remaining four mounting holes is manufacturer specific.

**Figure 12.1-1: Mechanical Outline Dimensions**



**Figure 12.1-2: Mechanical Dimensions**



DETAIL A  
SCALE 2 : 1

## 13 Appendix A: Open Issues / Current Work Items

None

## 14 Appendix B: List of Companies and Contributors

### 14.1 Technical Contributors (to the Original Document)

Bookham	Tim Simmons	Timothy.Simmons@bookham.com
Nortel	Peter Anslow	<a href="mailto:pja@nortel.com">pja@nortel.com</a>
Intel	Raj Batra	Raj.batra@intel.com
Iolon	Jeff Hutchins	jeff@iolon.com
Iolon	Mehrdad Roosta	<a href="mailto:mroosta@iolon.com">mroosta@iolon.com</a>
Harris Corporation	Jerry Wood	Jerry.wood@essexcorp.com

### 14.2 List of OIF Member Companies (at time of adoption)

ADVA Optical Networking	Flextronics	Nortel Networks
Alcatel-Lucent	Force 10 Networks	NTT Corporation
Altera	France Telecom	Opnext
AMCC	Freescale Semiconductor	PMC Sierra
Analog Devices	Fujitsu	Sandia National Laboratories
Anritsu	Furukawa Electric Japan	Santur
AT&T	Huawei Technologies	Sierra Monolithics
Avago Technologies Inc.	IBM Corporation	Silicon Logic Engineering
Avalon Microelectronics	IDT	Soapstone Networks
Avanex Corporation	Infinera	Sycamore Networks
Bookham	IP Infusion	Syntune
Broadcom	JDSU	Tektronix
BT	KDDI R&D Laboratories	Telcordia Technologies
China Telecom	Level 3 Communications	Telecom Italia Lab
Ciena Corporation	LSI Logic	Tellabs
Cisco Systems	Marben Products	Texas Instruments
ClariPhy Communications	MergeOptics GmbH	Time Warner Cable
CoreOptics	Mintera	Tyco Electronics
Cortina Systems	MITRE Corporation	Verizon
Data Connection	Mitsubishi Electric Corporation	Vitesse Semiconductor
Department of Defense	Molex	Yokogawa Electric Corporation
Deutsche Telekom	Music Semiconductors	ZTE Corporation
Emcore	NEC	
Ericsson	NeoPhotonics	
Finisar Corporation	Nokia Siemens Networks	

## 15 Document Index

### A

Absolute Maximum Ratings .....	23
ADT .....	63, 69
Aging .....	55
ALM* .....	56, 63, 69
Application space	
Distance .....	92
Long Haul .....	95
Metro .....	96
Tuning Time Specification .....	97
Ultra Long Haul .....	94
AXC .....	69

### B

BIP-4 .....	27, <i>See</i> Checksum
Bit Numbering .....	<i>See</i> Conventions

### C

CE .....	18, 25, 27, 56, 57, <i>See</i> Communication error
CEL .....	56, 57, 61
Checksum .....	27
Checksum (BIP-4) .....	14
CIE .....	<i>See</i> Error Field
CIL .....	<i>See</i> Error Field
CIP .....	<i>See</i> Error Field
Command Format .....	29
Command Group	
Generic module commands .....	36
Manufacturer Specific .....	86
Optical Settings .....	64
Status Commands .....	54
Command Paradigms .....	15
Command volatile attribute .....	35
Commands	
Command Description Format .....	34
Data value .....	35
Error Condition Field .....	35
Execution Time .....	35
Pending Operation .....	35
Response generated attribute .....	34
Returns attribute .....	35
Status Field Returned .....	35
Commands <i>Can be pending</i> .....	34
Commands: .....	35
Communication Byte Numbering .....	24
Communication error .....	14
RS-232 .....	25

Communication Interface .....	<i>See</i> Physical Interface
Connector	
Electrical.....	19
Pin assignments .....	19
Conventions.....	11
Bit Numbering.....	11
Byte numbering .....	24
Data Direction .....	12
Data Types.....	11
Numeric Values.....	11
CRL.....	56, 58, 61

---

**D**

Data Direction .....	<i>See</i> Conventions
Data Types.....	17, <i>See</i> Conventions
Diode Degradation.....	83
Document	
Scope.....	13

---

**E**

EAM.....	47, 48
Electrical Characteristics .....	19, 22, <i>See</i> Specifications
ERE .....	<i>See</i> Error Field
ERO.....	<i>See</i> Error Field
Error Condition Field .....	35
Error Detection	
By Host.....	18
By Module.....	18
Error field .....	35, 36
Error Field .....	17
CIE - Command ignored while output enabled .....	17
CII - Command ignored while initializing.....	17
CIP - Command ignored due to pending operation .....	17
ERE - Extended address range error.....	17
ERO - Extended address is read only .....	17
EXF - Execution general failure .....	17
IVC.....	17
OK – No errors .....	17
RNI – Register no implemented .....	17
RNW – Register not write-able .....	17
RVE – Register value range error.....	17
VSE - Vendor specific error .....	17
Example	
Extended Addressing.....	16
Reading Module Status.....	15
Execution Error Detection.....	18
Execution Error Timing	
RS-232.....	25
EXF .....	<i>See</i> Error Field
Extended Addressing.....	16

---

**F**

FATAL*	56, 62, 69
FFREQ	55, 56, 57, 63, 87
FFREQ_L	55, 56, 58, 61, 62
flag	
CP	46
FPWR	55, 56, 57, 63, 87
FPWRL	55, 56, 58, 61, 62
FTHERM	55, 56, 57, 63, 87
FTHERML	55, 56, 58, 61, 62
FVSF	55, 56, 57, 63, 87
FVSFL	55, 56, 58, 61, 62

---

**H**

hardware module reset	68
-----------------------	----

---

**I**

In-Bound packet	27, 29, 48
INCR	47, 48
Interfaces	
Communication	24
Invalid configuration, MRDY	37
IOCap	31, 45

---

**L**

Lifetime	83, 84
Long haul	92

---

**M**

Mechanical Specifications	
Module	99
Metro	92
MRDY	<i>See NOP/Status (0x00)</i>
MRL	56, 57, 61, 62
MS*	18, 21, 24, 25, 26, 68

---

**N**

Numeric Values	<i>See Conventions</i>
----------------	------------------------

---

**O**

OK	<i>See Error Field</i>
Optical Characteristics	92
Out-Bound packet	27, 29



**Overview**

Address registers .....	16
Command .....	15
Command Execution Overlap .....	15
Communication .....	14
Communication Layers .....	14
Data Types.....	17
Multi-byte.....	17
Two Byte.....	17
Error Detection.....	18
Extended Addressing.....	16
Module Reset.....	17
Physical Interface .....	15
Register configuration .....	16
Transport Layer .....	27

---

**P**

Packet status flags	
AEA.....	29, 30
CP.....	29, 30
XE.....	30
Packet status flags	
XE.....	29
Packet Status Flags.....	29
Pending operation.....	35
Pending operations .....	15
Physical interfaces.....	19
Pin Functions.....	20
RS-232.....	24
Physical Interfaces.....	15
Pin Assignments .....	19
Pin Functions .....	20

---

**R**

RAI.....	47
References .....	11
Register	
Age.....	83, 84
ALMT.....	63
Channel.....	64
CTemp.....	73
Currents .....	78
DevTyp.....	37
Dither(E,R,A,F).....	80
DLConfig.....	50
DLStatus.....	53
Extended Addressing.....	45
FAgeTh.....	57, 83, 84
FatalT .....	62
FCF1 .....	71
FCF2.....	71, 85
FFreqTh.....	59

FPowTh .....	58
FThermTh .....	60
GenCfg .....	18, 35, 44, 71
Grid .....	70
IOCap .....	25, 45
LF1 .....	72
LF2 .....	72
LGrid .....	77
LstResp .....	48
MCB .....	69
MFGDate .....	40
MFGR .....	38
Model .....	38
NOP/Status .....	36
OOP .....	73
OPSH .....	75
OPSL .....	75
PWR .....	66
RelBack .....	43
Release .....	41
SerNo .....	39
SRQT .....	61
StatusF .....	54
StatusW .....	54
TBTFH .....	82
TBTFL .....	82
Temps .....	79
WAgeTh .....	57, 83, 84
WFreqTh .....	59
WPowTh .....	58
WThermTh .....	60
Registers	
Summary .....	31
Reset, module .....	17
Response flag .....	14
Response generated .....	34
RNI .....	<i>See Error Field</i>
RNW .....	<i>See Error Field</i>
RS-232	
Baud rates .....	26
Error Timing .....	25
Execution Timing .....	25
RVE .....	<i>See Error Field</i>

---

**S**

SBS suppression .....	80
SDC - Store default configuration .....	44
SDF .....	55, 64, 68, 69
SENA .....	56, 64, 68, 69
soft reset .....	68
SRQ* .....	18, 20, 25, 32, 55, 56, 57, 61, 62, 66
Status Flags .....	<i>See Packet Status Flags</i>

---

**T**

Transport Layer	
Transport Layer Field Definitions .....	27

---

**U**

Ultra long haul.....	92
----------------------	----

---

**V**

VSE .....	<i>See Error Field</i>
-----------	------------------------

---

**W**

WAI.....	47
WFREQ.....	55, 56, 57, 63, 88
WFREQ_L .....	55, 56, 58, 61, 62
WPWR .....	55, 56, 57, 63, 66, 88
WPWRL .....	55, 56, 58, 61, 62
WTHERM.....	55, 56, 57, 63, 82, 88
WTHERML.....	55, 56, 58, 61, 62
WVSF.....	55, 56, 57, 63, 88
WVSFL .....	55, 56, 58, 61, 62

---

**X**

XE16, 18, 25, 36, 37, 38, 39, 40, 41, 43, 44, 45, 46, 49, 50, 53, 54, 56, 57, 58, 59, 60, 61, 62, 63, 64, 66, 67, 69, 70, 71, 72, 73, 74, 75, 76, 77, 78, 79, 80, 82, 83, 85	
IVC.....	<i>See Error Field</i>
XEL .....	56, 57, 61